

TRAMPOLINE 12FT RECTANGULAR WITH ENCLOSURE

KEYCODE:43062706

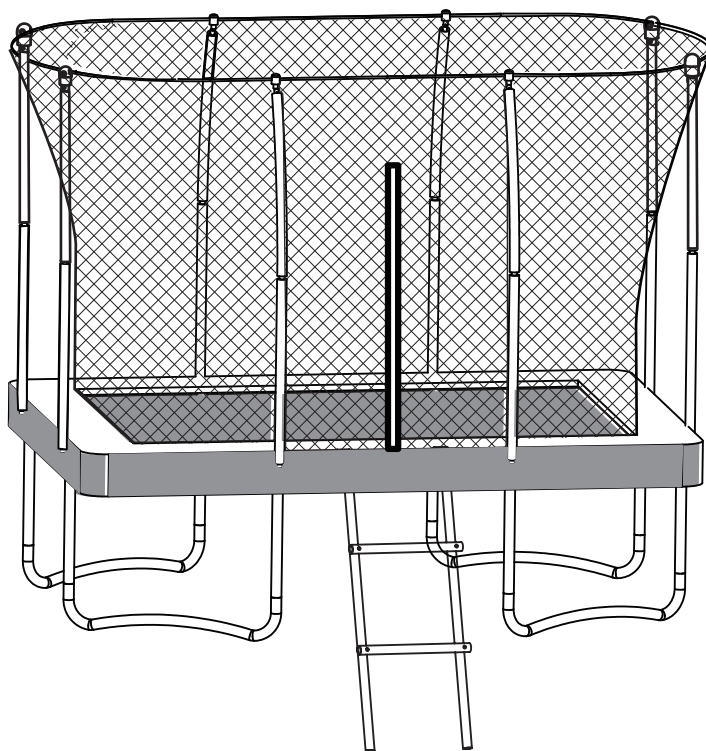

WARNING!

**SAFETY INFORMATION, INSTALLATION AND MAINTENANCE INSTRUCTIONS:
READ THESE MATERIALS PRIOR TO ASSEMBLING AND USING THE TRAMPOLINE.
PLEASE READJUST PRODUCT TO THE LOWEST HEIGHT AND STORE IT SAFELY
WHEN NOT IN USE OR BEFORE BAD WEATHER WITH SEVERE WIND.**

Important

The owner's manual contains safety, assembly, use and maintenance instructions. The product must be assembled by an adult who has read and understood these instructions. Keep the packaging away from children and dispose of all packaging before use. It is best to keep the instructions for future reference.

For the installer and your children's safety, it is important to fully read and understand the instructions and safety hazards before commencing the assembly of the product. It is advised to retain the manual for future reference.

ATTENTION!

**SAFETY INFORMATION, INSTALLATION, CARE
AND MAINTENANCE INSTRUCTIONS.**

READ PRIOR TO ASSEMBLING AND USING THE TRAMPOLINE

CUSTOMER SERVICE:

Name: JCA Collective

Email: service@jcacollective.com

Phone Number: +61 423 259 751 Office Hours: Monday to Friday 9am to 5pm

TABLE OF CONTENTS

1.	GENERAL SAFETY INSTRUCTIONS	2
1)	PURPOSE	2
2)	DANGER FOR CHILDREN	2
3)	RISK OF INJURIES	3
4)	PRODUCT DAMAGE	3
5)	ASSEMBLY ADVICE	3
2.	SAFETY INSTRUCTIONS FOR TRAMPOLINES	4
1)	WARNINGS	4
2)	FOR THE SUPERVISOR	5
3)	ACCIDENT CATEGORIES	5
4)	METHODS OF ACCIDENT PREVENTION	6
5)	SAFETY USE INSTRUCTIONS	6
6)	SITTING INSTRUCTIONS	7
7)	FOR TRAMPOLINES REQUIRING PADDING	7
3.	ASSEMBLY INSTRUCTIONS	8 - 23
4.	WARNINGS	24 - 25
5.	MAINTENANCE	26
6.	EXERCISE INSTRUCTIONS	27 - 28
7.	CLEANING	29
8.	DISPOSAL ADVICE	29
9.	PRODUCT WARRANTY	30
10.	CUSTOMER SERVICE	31

GENERAL SAFETY INSTRUCTIONS

1.PURPOSE

The product is intended for home/domestic use only and is not suitable for professional or medical use.

2.DANGER FOR CHILDREN

- **WARNING!** Trampoline is not allowed for children under six years of age.
- Children using the trampoline must be 6 years of age and over. This trampoline is designed and manufactured to provide you and your family with many years of fun and exercise, but for your benefit and safety, children using this trampoline must be adequately informed of all warnings and safety instructions.
- Do not leave children unsupervised near this product.
- Be aware that the packaging material is not suitable for children. There is danger of suffocation!

3. RISK OF INJURIES

- Do not use the product if it is damaged or defective. If this is the case, please consult a qualified technician.
- Check the product before every use. Defective parts must be changed immediately as they can impair the function and the safety of the product.
- Make sure that no more than one person is using the product at the same time.
- Use the product only on even and non-slipping surfaces. Never use it near water and keep sufficient space around it to increase security.
- Beware of moving parts, which could catch your arms and legs. Do not stick any objects in the product's openings.

4. ATTENTION -PRODUCT DAMAGE

- Please do not alter the product. Only use original spare parts. Qualified technicians should only carry out repairs – improper repairs can lead to danger for the user. Use this product only as described in this manual.
- Protect the product against splashes, humidity and high temperature .

5. ASSEMBLY ADVICE

- The assembly of the product must be done carefully and by **two adults** . If in any doubt, ask a technically qualified person. It is important that children are not involved in the assembly of the trampoline.
- Before you start with the assembly, read the instructions carefully and take a look at the assembly instructions.
- Remove all packaging materials and lay down all parts on a flat and open space. This gives you an overview and simplifies the assembly procedure.
- Now, check with the parts list that no part is missing. Dispose of the packaging material when the assembly is completed.
- Create a danger free environment; for example, do not let tools lay around the workspace. Store the packaging material in a way that cannot cause any danger. Foils and plastic bags are dangerous for children (danger of suffocation)!
- After installing the product according to the instruction manual, please make sure that all screws, bolts and nuts are correctly installed and tightened and that all joints are tightly fixed.
- A free space of at least 8m is necessary above the trampoline. An appropriate free space must be kept between the trampoline and possible sources of danger, such as electric cables, tree branches, playing devices, swimming pools and fences.
- The Trampoline must be set up properly before use.
- Never set up the trampoline in heavy rain, wind or storm conditions. It is recommended that the trampoline be taken away and stored in bad weather to prevent damage.
- The metal frame of the trampoline will conduct electricity. Lightning, extension cords and all electrical equipment must never be allowed to come in contact with the trampoline.
- The Trampoline must always be used in a well-lit area.
- Nothing must be placed under the trampoline.
- The Trampoline in the vicinity of other leisure devices and constructions must not be used.
- When assembling or disassembling , please use gloves to protect your hands.

SAFETY INSTRUCTIONS FOR YOUR TRAMPOLINE

WARNINGS!



Do not land on head or neck.
Do not attempt or allow somersaults.
Landing on your head or neck can cause serious injury, paralysis, or death, even when landing in the middle of the mat.
If an enclosure is fitted-do not pull top of the net.
Ensure adult supervision is provided at all times.



Only one person at a time on the trampoline.
Do not allow more than one person on the trampoline. Use by more than one person at the same time increases the chance of injury.
Misuse and abuse of this trampoline can cause serious injuries.
This trampoline is not recommended for children under 6 years of age.

- Do not use the trampoline without supervision, regardless of age and experience.
- The safety instructions of the trampoline should always be considered and followed. During the use of the trampoline, there is a heavy danger of injury including permanent injuries such as paralysis, or even death.
- Even landings on the trampoline can lead to injuries, particularly to the back, neck or head. Somersaults must be avoided. In any case, only one person should use the trampoline at a time.
- The importer, store, manufacturer nor supplier will be responsible or liable in any form for direct, indirect or special damages caused during the use or in connection with the product.
- This also applies to financial losses by theft, property loss, loss of earnings/services and profit, loss of satisfaction in the device, costs of the installation, disposal, damage by influences of the weather and environment as well as any other kinds of damages.
- Recognisable production defects are announced immediately by the dealer or manufacturer/ importer and shall be adjusted immediately for further use. The buyer/ operator of the trampoline has to examine the device regularly on wears or damage.
- No clothes with hooks or loose parts may be carried when jumping on the trampoline, in order to avoid hooks getting caught.
- The trampoline may be set up only on a flat ground.
- Strong winds can blow the trampoline away. If strong winds are predicted, the trampoline must be moved to a protected place, and taken apart, or fastened to the ground with cords and herrings. At least three anchorages are necessary. It is not enough to anchor the pennants in the ground since they can tear out of the patch cords.
- Try to avoid moving the assembled trampoline, because it could bend during transportation. Should it be necessary to move the trampoline, please consider the following:
 - 1.) At least four adults must be evenly spaced around the frame to lift the trampoline off the ground.
 - 2.) The trampoline must be carried horizontally
 - 3.) Be careful while moving, because the frame could bend. If this happens, use four adults to draw the trampoline into shape.
- Trampolines are jumping devices, enabling the user to jump into unusual heights as well as into a multiplicity of body movements. Jumping in the trampoline, hitting the frame, cushioning or incorrect landing on the trampoline can lead to injuries.
- All users must read the recommendations of the manufacturer themselves to ensure they use the device correctly.
- Users should be familiar with the assembly manual. This manual contains assembly guidance; selected precautionary measures as well as recommendations for servicing and maintenance of the trampoline, in order to ensure a secured and fun use of the trampoline.
- It is the responsibility of the owner or the supervisor to guarantee that all users of the trampoline are informed sufficiently of all warning references and safety instructions.

SAFETY INSTRUCTIONS FOR YOUR TRAMPOLINE

FOR THE SUPERVISOR:

The supervisor's role is to make sure the users know all the safety rules as well as learn the basic, fundamental bounces. They need to enforce all the safety rules and warnings in the manual, frame and labels. When a supervisor is not available, the trampoline may be disassembled or covered to limit access.

- Implement all safety rules and make yourselves familiar with the information in the user manual.
- All users of the trampoline need a supervisor, the user of the trampoline must be aged 6 years or older.
- Do not recommend this trampoline for children under 6 years of age.
- The trampoline can only be used, if the jumping mat is clean and dry. Worn or damaged jumping mats should immediately be replaced.
- Objects which could be dangerous to the user, should be away from the trampoline
- Avoid unauthorized and unsupervised use of the trampoline.
- Do not use the trampoline under influence of alcohol or drugs (including medication).
- Learn the fundamental jump and body positions carefully, before trying difficult jumps.
- Stop jumping by bending your knees when your feet come to contact with the trampoline. The skill of braking should be used whenever you lose balance or control from a previous manoeuvre. Loss of balance or control will increase the risk of injury from landing on the frame, springs or completely off the trampoline. A controlled jump is considered landing on the same spot that you took off from. If you do lose control when you are jumping on the trampoline, bend your knees sharply when you land and this will allow you to regain control and stop your jump.
- Climb onto the trampoline. Do not jump on it directly. Do not use the trampoline as a jumping board for other articles.

ACCIDENT CATEGORIES

Somersaults: A landing on the head or neck increases the risk of neck and back injuries, which can lead to paralysis and sometimes death. This can occur if the user makes an error and falls forward or backward. No somersaults should be attempted on the trampoline.

The probability of an injury increases if more than one person is jumping on the trampoline. Users can collide, fall off the trampoline, land improperly on the jumping mat and on each other.

Climbing on or off the trampoline: The trampoline's jumping mat is approximately one metre above the ground. Jumping off the trampoline onto the ground or another surface can lead to an injury. Jumping onto the trampoline from a building roof, a terrace or other objects can lead to injury. Small children need assistance when climbing on or off the trampoline. Be careful when climbing on and off the trampoline. Do not step on the cushioning or the framework. Do not use the framework for climbing on or off the trampoline.

Hitting the framework or the springs: When playing on the trampoline, stay in the centre of the mat. This will reduce your risk of getting injured by landing on the frame or springs. Always keep the frame pad covering the frame of the trampoline. DO NOT jump or step onto the frame pad directly since it is not intended to support the weight of a person.

Loss of control: when users lose control of their jump, they can land wrongly on the jump mat, land on the framework or the cushioning or fall down from the trampoline. A controlled jump is one where the jumper lands and jumps from the same spot. Before a more difficult jump manoeuvre is practiced, the basic controlled jump should be mastered perfectly and continuously. If a jump manoeuvre is attempted, which exceeds the abilities of the jumper; there is a danger of losing control. In order to regain control of the jump and land correctly, knees should be completely bent upon landing.

SAFETY INSTRUCTIONS FOR YOUR TRAMPOLINE

Under influence of drugs or alcohol: The probability of an injury rises if the user is under the influence of alcohol or drugs. These substances weaken the response, the faculty of judgment, the space awareness, the co-ordination and the motor functions of the user.

Collision with objects: while using the trampoline, person, animals or articles under it will increase the probability of an injury. Jumping on the trampoline while carrying an article, increases the probability of an injury. Placing the trampoline too close to electric wires, tree branches or other obstacles will increase the probability of an injury.

Bad maintenance of the Trampoline: Users can hurt themselves if the trampoline is in bad condition. A torn jumping mat, bent framework, missing cushioning or missing framework must be replaced before using the trampoline again. The trampoline should be examined before each use.

Weather conditions: A wet jumping mat is too slippery for safe jumping. Gusty or strong winds can lead to a loss of jump control when jumping. In order to lower the probability of an injury, the trampoline should be used under suitable weather conditions only.

Please readjust product to the lowest height and store it safely when not in use or before bad weather with severe wind

METHODS OF ACCIDENT PREVENTION

Role of the user in preventing accidents:

A basic knowledge of the trampoline by the user is a must for security. All users of the trampoline must learn first how to accomplish a low controlled jump as well as the fundamental landing positions and combinations, before turning to advance jump exercises. Users must know why they must control their jump, before they may practice other movements. A controlled jump is when you land and take off from the same location. The first lesson is the understanding of the correct order in developing jumping skills on a trampoline. For further information or exercise materials, please turn to a trained trampoline instructor.

Role of the supervisor in preventing accidents:

It lies in the responsibility of the supervisors to guarantee a reasonable and experienced supervision of the users of trampoline. Rules and warnings in this manual must be applied, and known to the users of the trampoline in order to reduce the probability of accidents and injuries. In times, when the supervision is not possible or insufficient, the trampoline should be dismantled and stored in a secured place against unauthorized use.

SAFE USE INSTRUCTIONS

- A) Read all instructions before using the trampoline.
- B) Allow only one person on the trampoline at any time. Use by more than one person at the same time can result in serious injury.
- C) Use the trampoline only with mature, knowledgeable supervision at all times.
- D) Inspect the trampoline before each use. Make sure the frame padding is correctly and securely positioned. Replace any worn, defective, or missing parts.
- E) Keep objects away which could interfere with the user. Maintain a clear area around, above, and under the trampoline.
- F) Learn fundamental bounces and body positions thoroughly before trying more advanced skills.

SAFETY INSTRUCTIONS FOR YOUR TRAMPOLINE



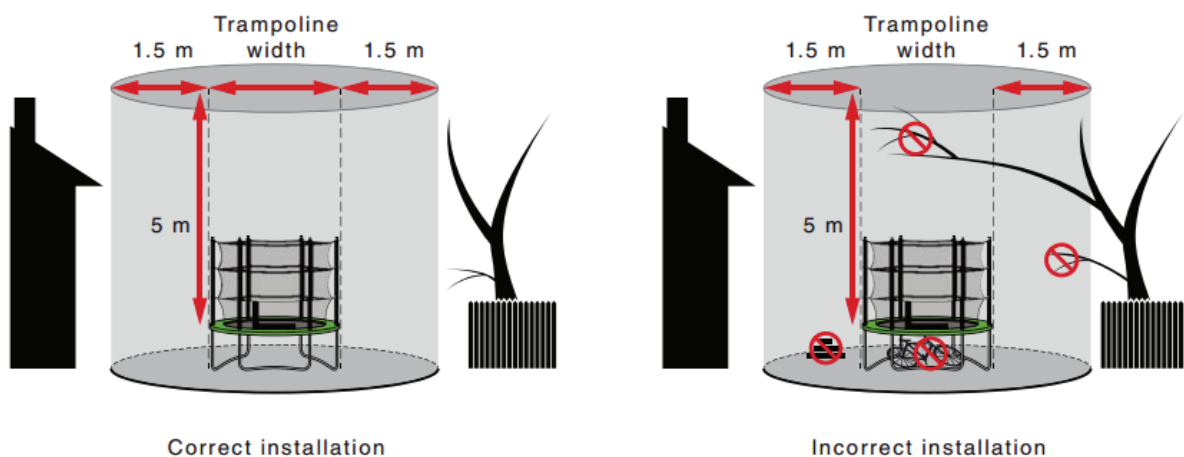

SITTING INSTRUCTIONS





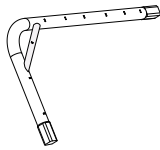
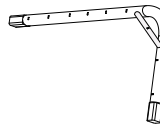
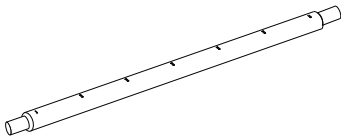
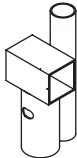
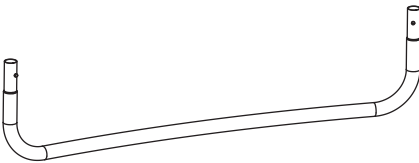

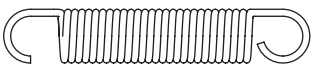
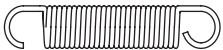
- (a) Place the trampoline on a flat level surface with impact attenuating properties such as grass and ensure that it is sufficiently stable to prevent it from tipping over and/or blowing away. Sandbags or pegs may be suitable anchorage devices.
 - (b) Adequate overhead clearance is essential. A minimum of 8m from ground level is recommended. Provide clearance for wires, tree limbs, and other possible hazards.
 - (c) Lateral clearance is essential. Place the trampoline away from walls, structures, fences, and other play areas.
 - (d) Maintain a free space of minimum 2500 mm on all sides of the trampoline. This area should not include concrete, bitumen, brick or other hard surfaces as these can cause serious injuries.
- NOTE: For trampolines with enclosures, the free space may be reduced to 1500 mm.
- (e) Keep the trampoline on a level surface.
 - (f) Use the trampoline in a well-lighted area.



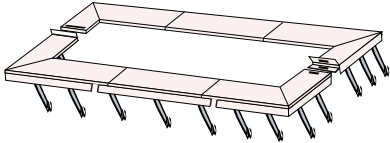
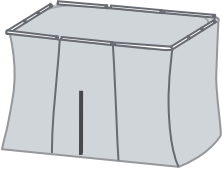



FOR TRAMPOLINES REQUIRING PADDING

- (A) Inspect the trampoline before each use and replace any worn, defective, or missing parts.
- (B) The following conditions could represent potential hazards:
 - a. Missing, improperly positioned, or insecurely attached frame padding.
 - b. Punctures, frays, tears, or holes worn in the bed or frame padding.
 - c. Deterioration in the stitching or fabric of the bed or frame padding.
 - d. Broken or stretched springs.
 - e. A bent or broke frame.
 - f. A sagging bed

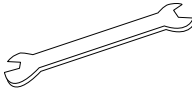
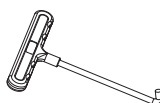
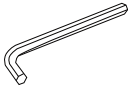
Key Number	Diagram	Description	Quantity
1-A		Curved Top Rail 1-A	2
1-B		Curved Top Rail 1-B	2
2		Straight Top Rail	4
3		Bracket with welding	8
4		Leg	4
5		Leg Extension	8
6-A		Long Spring 6-A	76
6-B		Short Spring 6-B	4
7		Mat	1

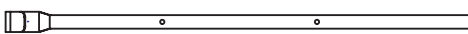
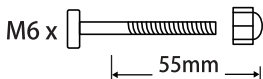
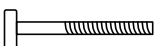
Key Number	Diagram	Description	Quantity
8		Frame Pad	1
9		Enclosure net	1
10		Enclosure net tie down strap with needle	1
11		Lower enclosure pole	8
12		Upper enclosure pole	8
13-A		Long Steel Top Rim 13-A	4
13-B		Short Steel Top Rim 13-A	4
14	 M6*18MM	Plastic connector with screw & spacer	8

Key Number	Diagram	Description	Quantity
15		Spanner	1
16		Spring tool	1
17		Hexagon wrench	1
18		Horizontal ladder tube	2
19		Vertical ladder tube	2
20	 M6 x   55mm	M6x55mm screw with nut	4

REMEMBER TO USE GLOVES DURING ASSEMBLY TO AVOID PINCHING.

AT LEAST 2 PEOPLE ARE REQUIRED TO ASSEMBLE THE TRAMPOLINE AND ENCLOSURE

ALWAYS WEAR PROTECTIVE GLOVES TO PROTECT AGAINST INJURY AS TRAMPOLINE AND ENCLOSURE ARE HEAVY EQUIPMENT.

BEFORE YOU BEGIN: Review all steps before assembly and read all precautions before using the trampoline.
At least two adults are required to assemble this trampoline. Protective gloves should be used during assembly to avoid pinching by the springs.

Step 1: Leg support Assembly

- Connect the two leg extensions(5) with leg base(4) as shows in figure 1.
- Repeat these steps for all legs.

Warning: Make sure that you have plenty of space and a clean,dry area suitable for assembling this trampoline
IT IS ESSENTIAL THAT THE INTENDED SITE FOR THIS TRAMPOLINE IS COMPLETELY FLAT AND LEVEL.

Figure 1

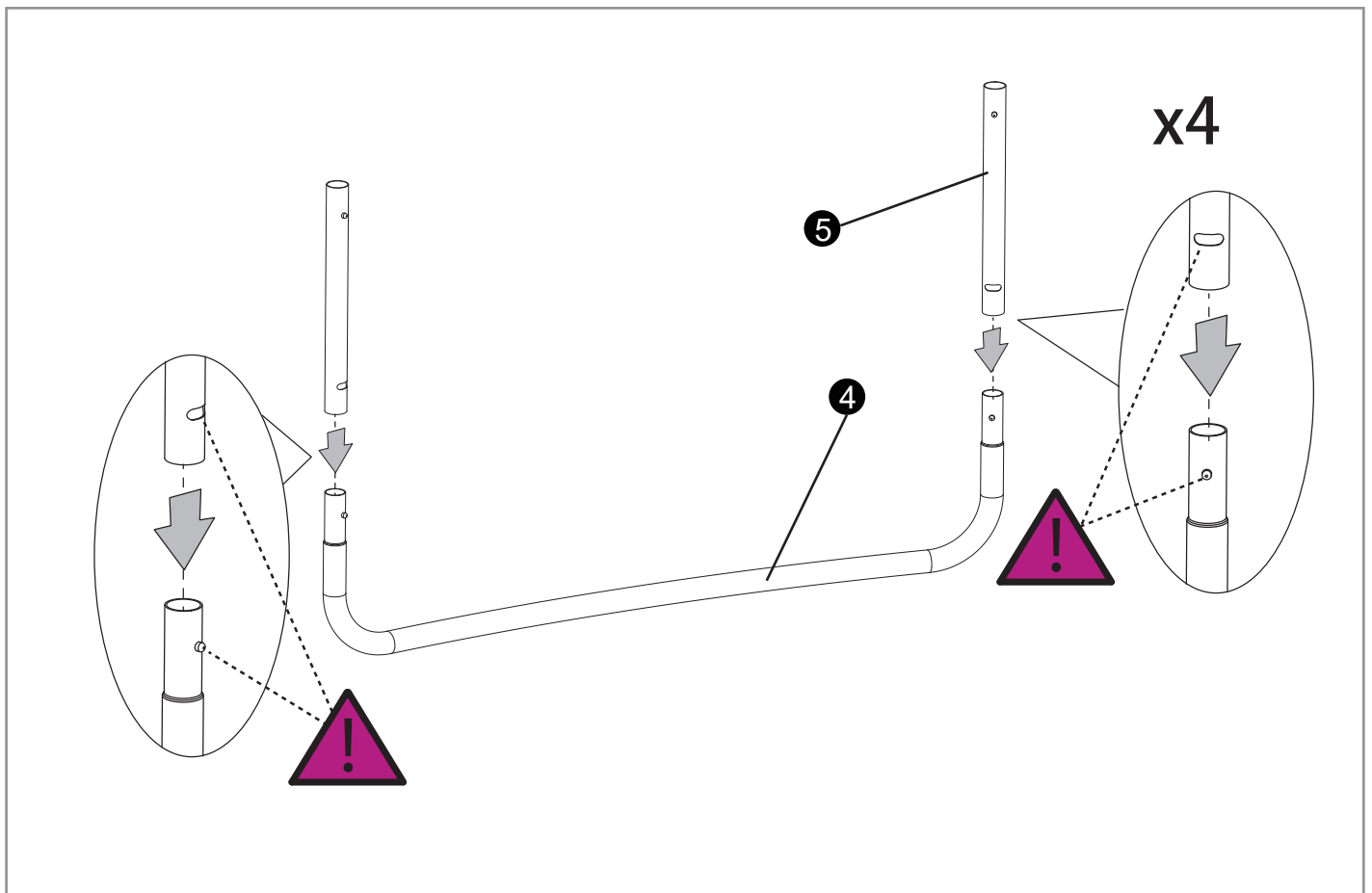

Step 2: Frame Assembly

Pick up top rail(1-A),connect both ends with bracket with welding(3),and pick up top rail (1-B),connect both ends with bracket with welding(3) as figure 2 shows
Repeat this step with all top rails as figure 2 shows.

Connect bracket with welding(3)with left leg extension(5).

Repeat this step for all legs assembly as figure 3 shows.

Connect the straight top rail(2)to the bracket with welding(3)and repeat this 2 times for each top rail to finish frame assembly as Figure 4 shows.

Figure 2

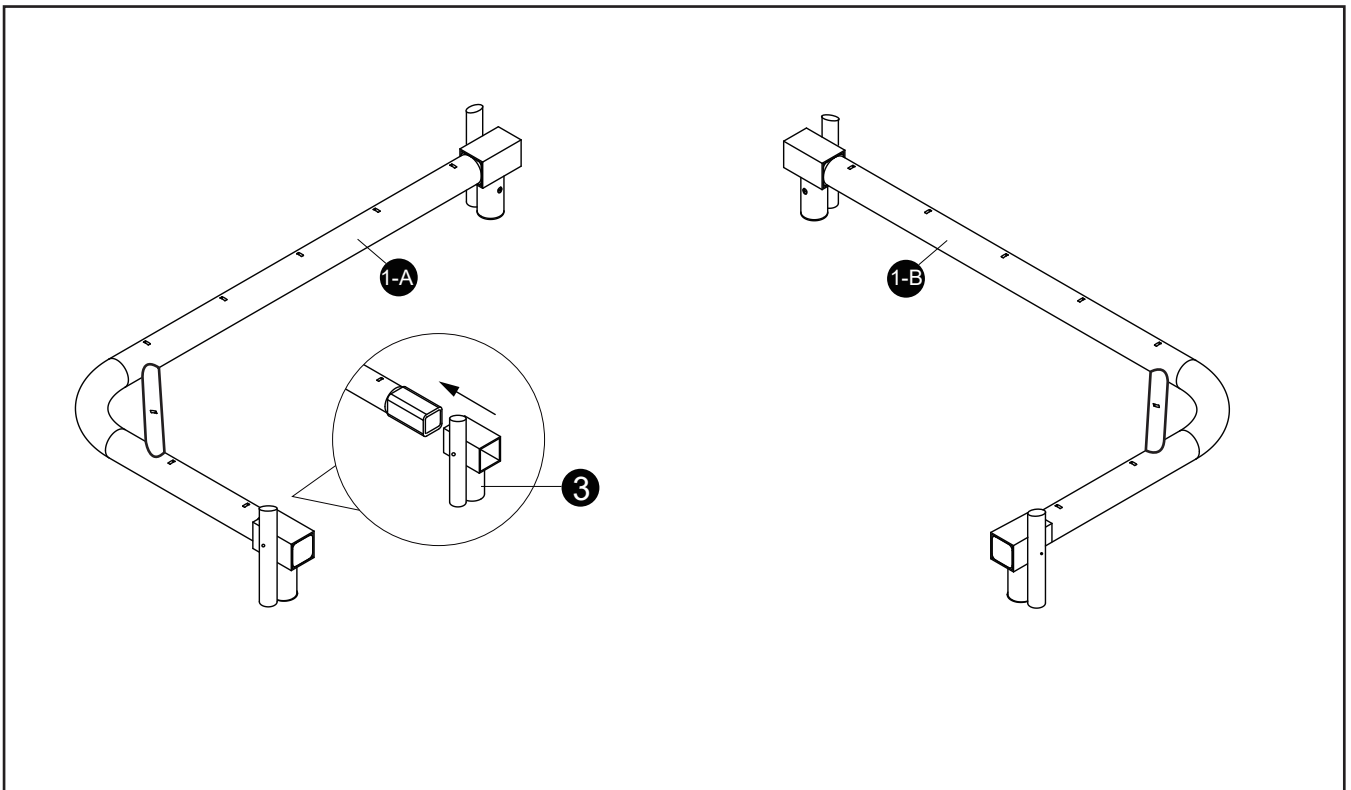

Figure 3

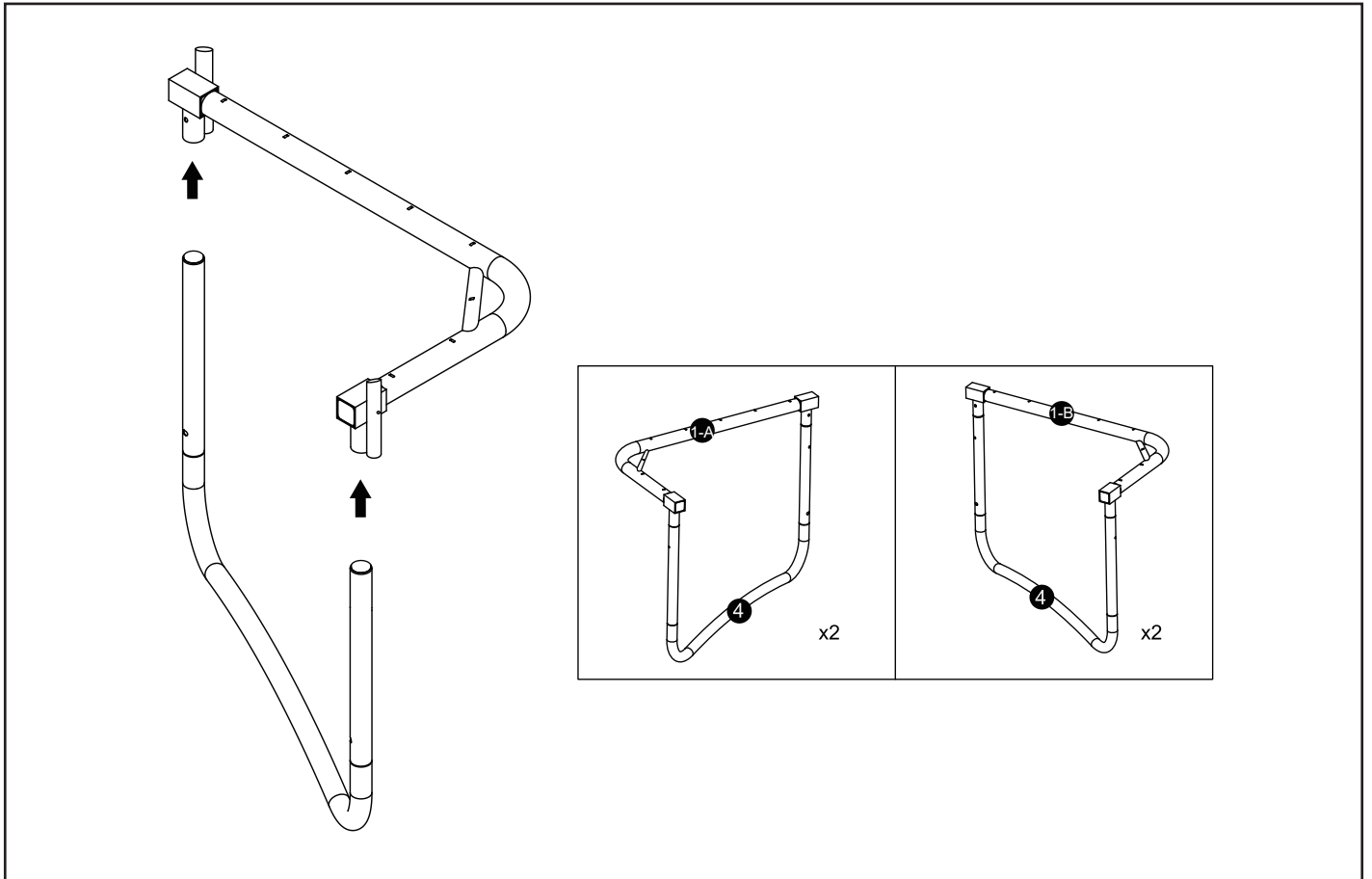
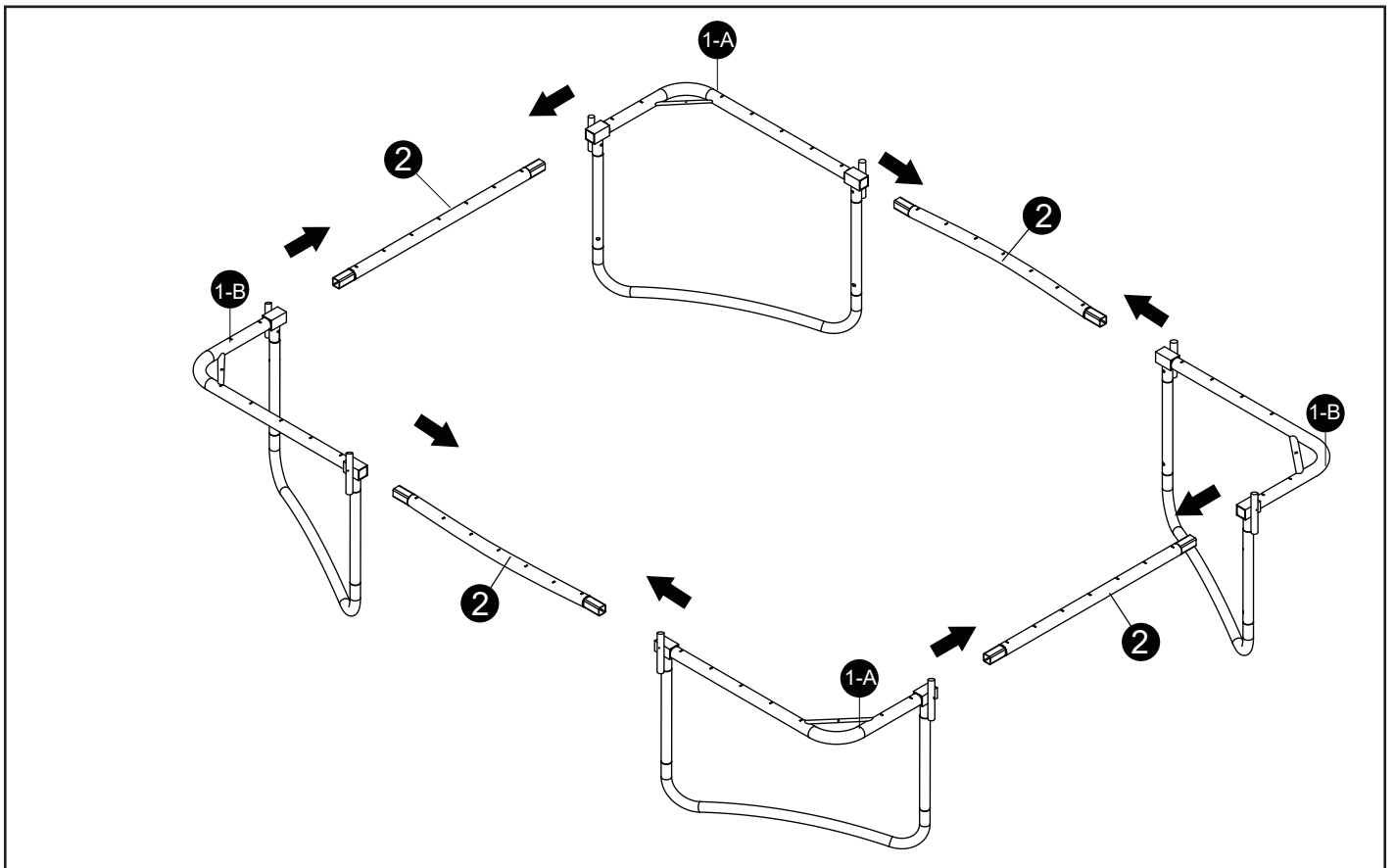
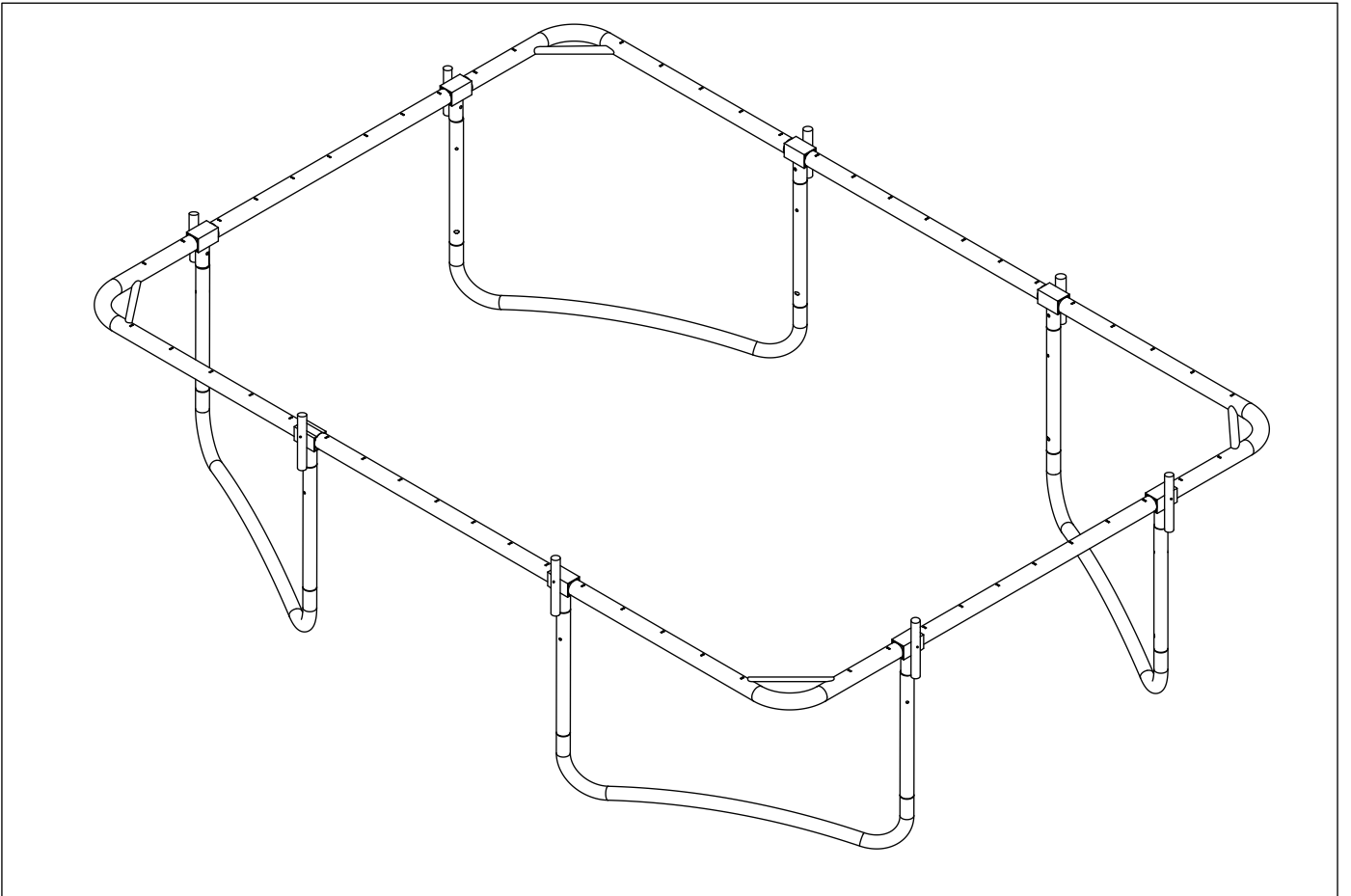
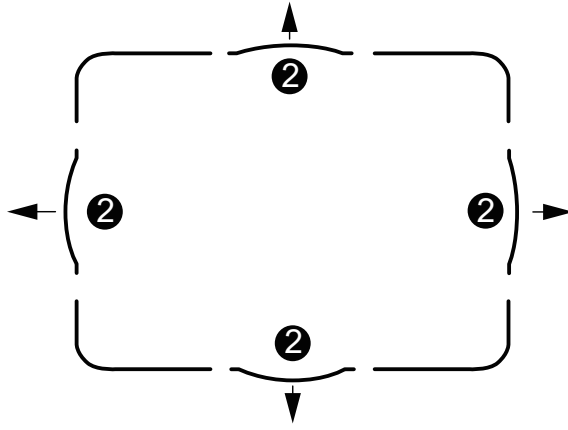

Figure 4





Step 3: Spring Assembly

Warning!

When attaching the springs, do not place your hands, arms, legs or any other body part close to the connector points (i.e. joints connecting the steel tubes). The connector points can become pinch points as the trampoline springs tighten up. Wear heavy duty working gloves to protect your hands from pinching by the springs and protective goggles to avoid injuries to the eyes. Be steady when installing the springs as it can rebound and fly off if you inadvertently let go when not hooked properly. Make sure no children are playing nearby when installing or assisting in the assembly of the trampoline.

- **Starting from the 8pcs of right & left springs next to corner springs, hook one end of the spring(6-A) into the triangle-ring on the mat(7). Holding the spring tool(16) in hands, pull the other end of the spring and lock it into the hole on the frame as shown in figure 5.**
- **After you have secured the 8pcs of right & left springs next to corner springs, place one spring at the middle hole on each of four straight top rails, hook one end of the spring(6-A) into the triangle-ring on the mat(7). Holding the spring tool(16) in hands, pull the other end of the spring and lock it into the hole on the frame as shown in figure 5.**
- **Attach the rest of the springs in the same manner as the previous steps until remove all springs are assembly. Please note 4pcs of corner springs should be 6-B, and the rest are 6-A.**
- **The number of triangle-rings sewn onto the mat is equal to the number of holes on the frame. If you notice that you have miscounted a hole or triangle-ring, remove and reinstall the springs as necessary while maintaining an even distribution of tension as explained above.**

Figure 5

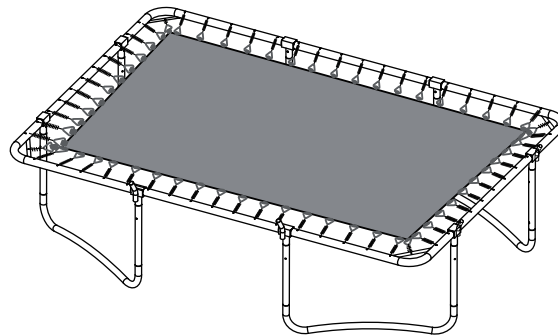
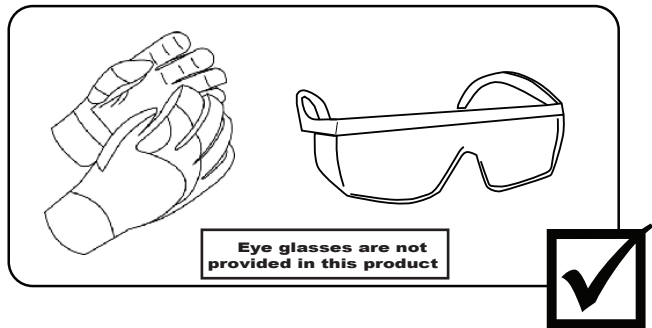
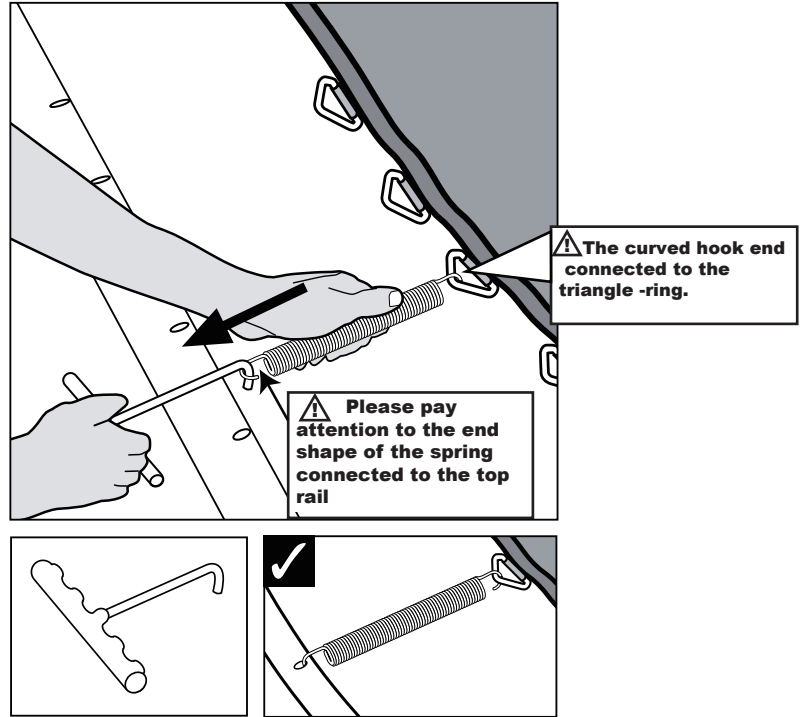
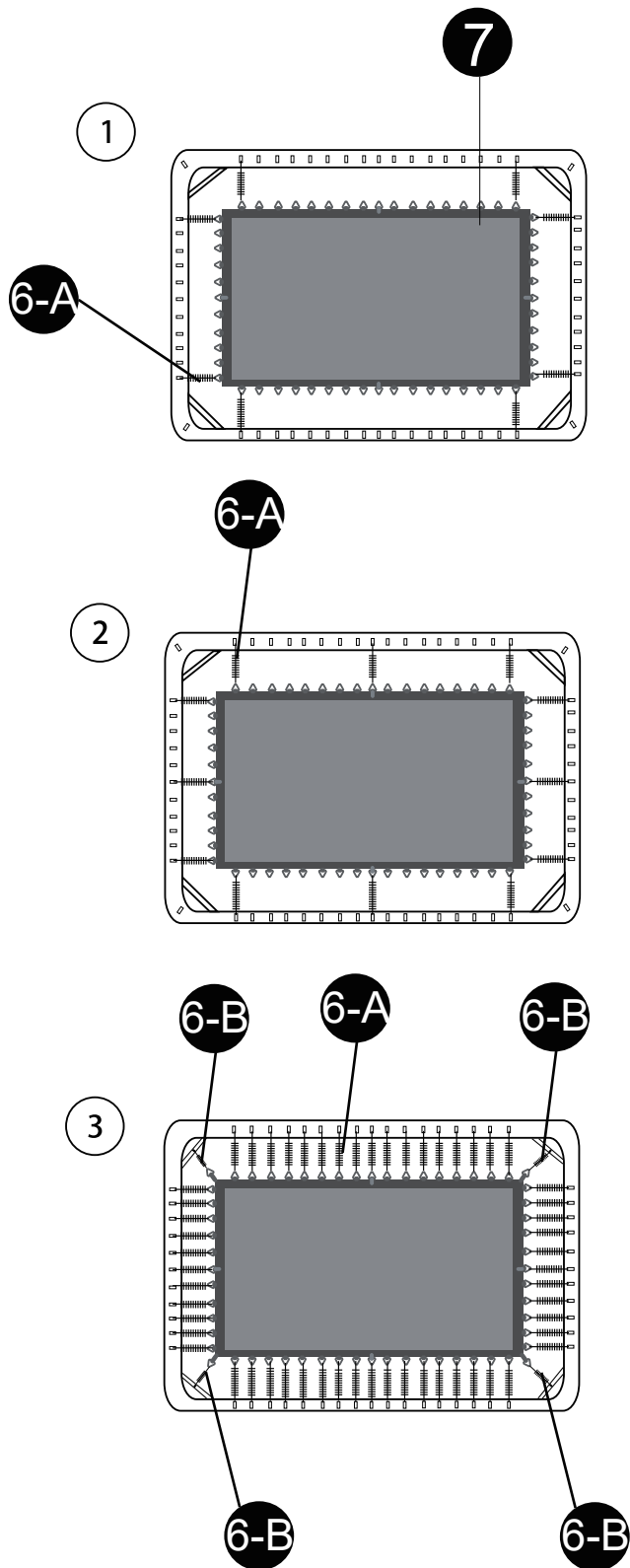

Step 4 Lower Enclosure Pole Assembly

- Connect lower enclosure pole(11) with bracket with welding(3)by clipping the pin.
- Repeat this 8 times as figure 6 shows to finish lower enclosure pile assembly.
After assembly, please make sure the pit pin is protuberant from the hole.

Figure 6

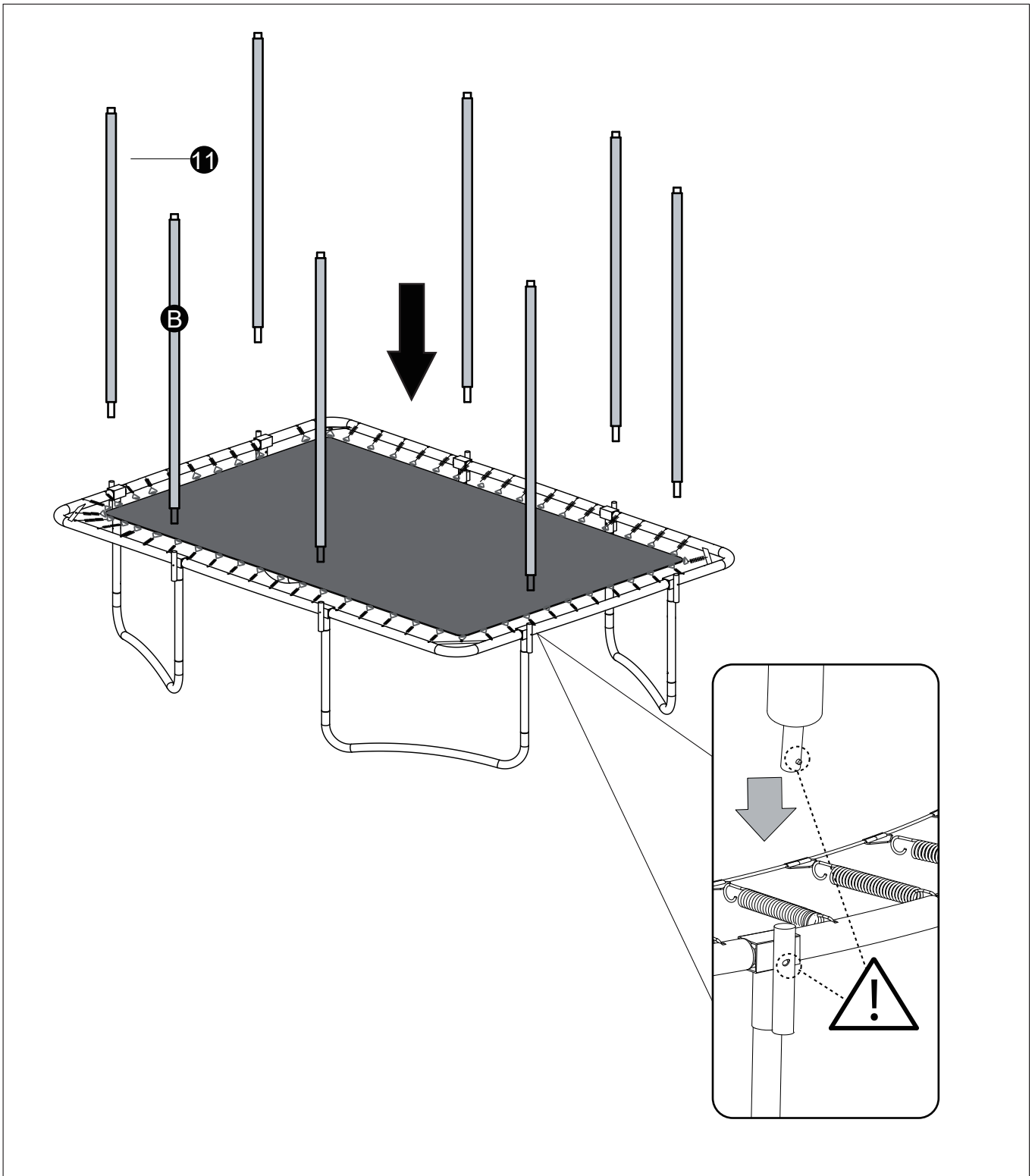

Step 5: Upper enclosure pole & safety net & top rim assembly

Let the whole steel top rim (13-A and 13-B) go through the tunnel on top of the enclosure net (9), then connect two adjacent steel top rim ends with plastic connector (14).

Line up the hole in the steel top rim(13-A and 13-B)and screw together ensuring the screw (14)also goes through the hole in the steel top rim.

Repeat for the remaining steel top rims and plastic connectors as Figure 8 shows.

Once complete, lift the steel top rim to the top of the upper enclosure poles (12)and plug the steel top rim connector into the hole of the upper enclosure pole until the locking pins click in place.

The direction of the upper enclosure pole must follow below diagram.

Connect the lower enclosure pole(11)and the upper enclosure pole(12)by putting the pit pin as Figure 9 shows

Connect cord with needle as figure 11 shows and repeat process 1,2 and 3.

Figure 8

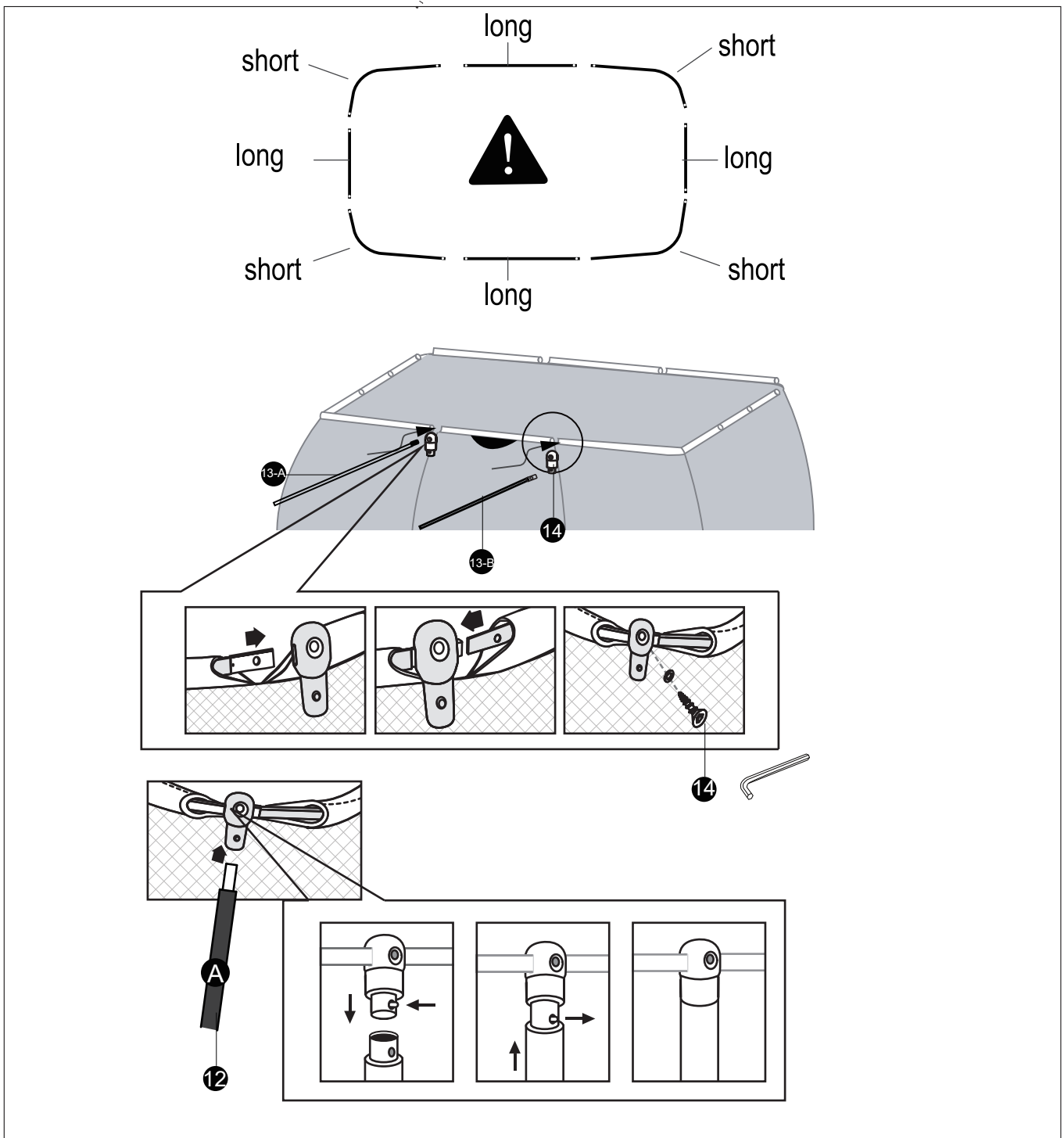

Figure 9

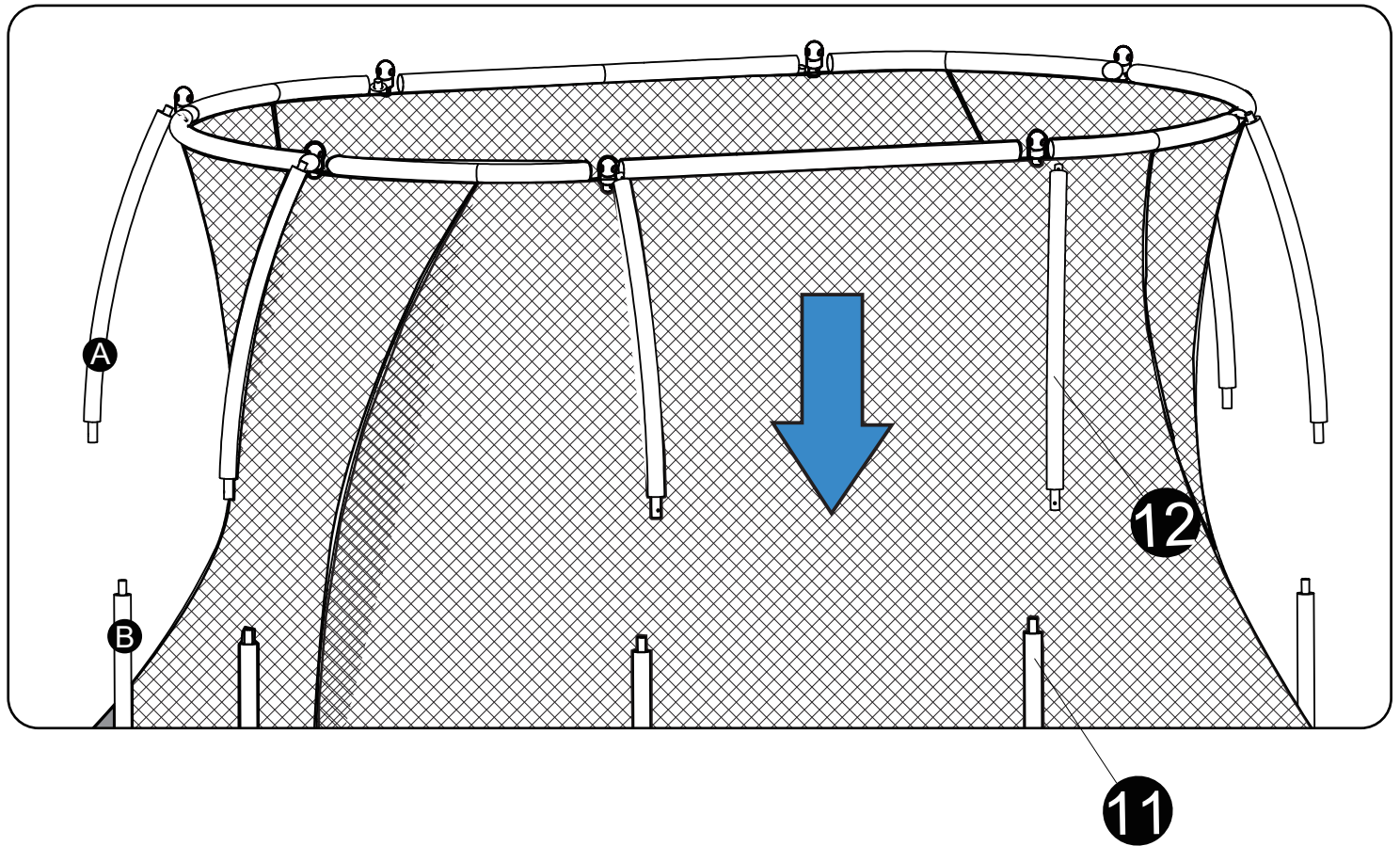

Figure 10

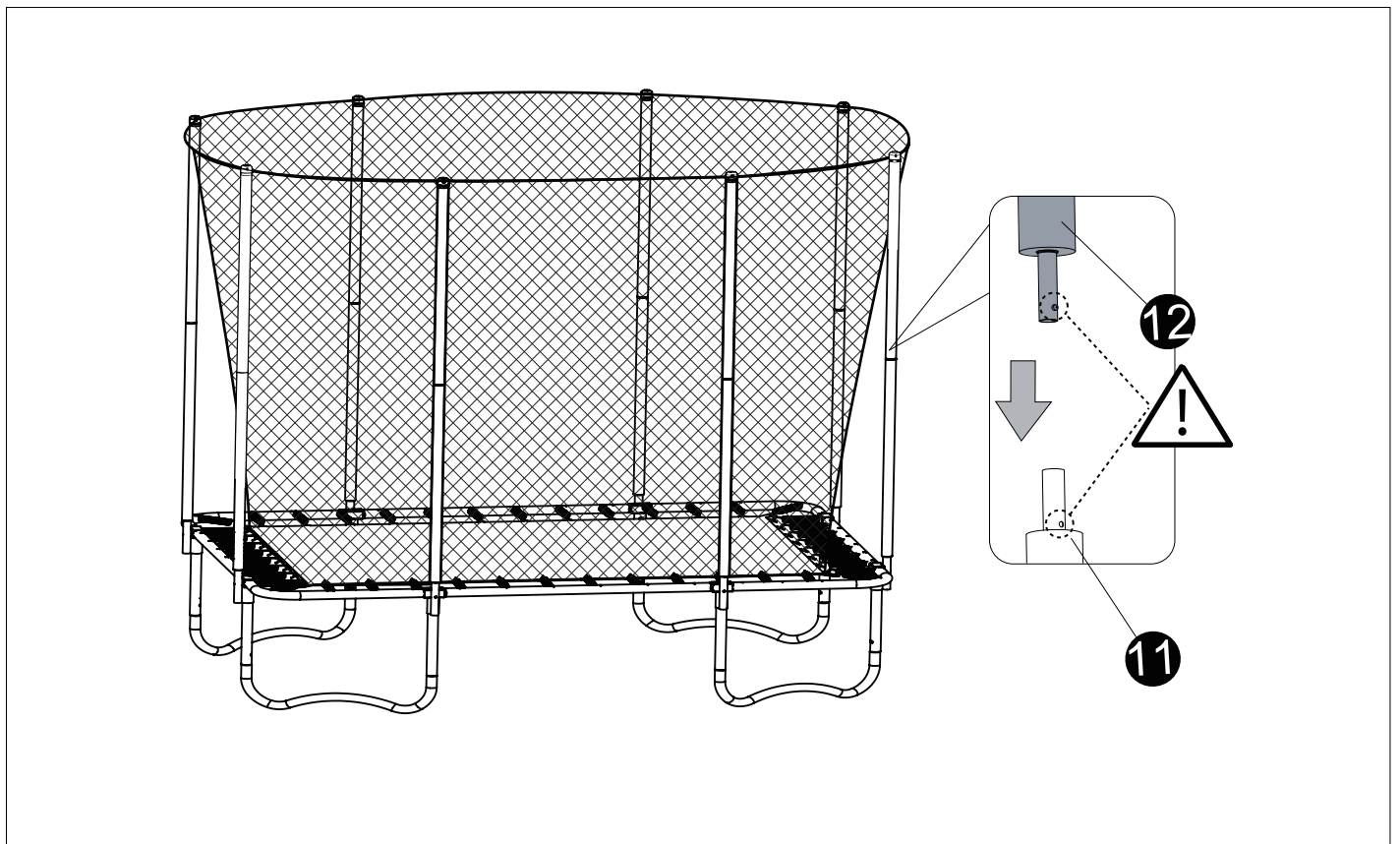
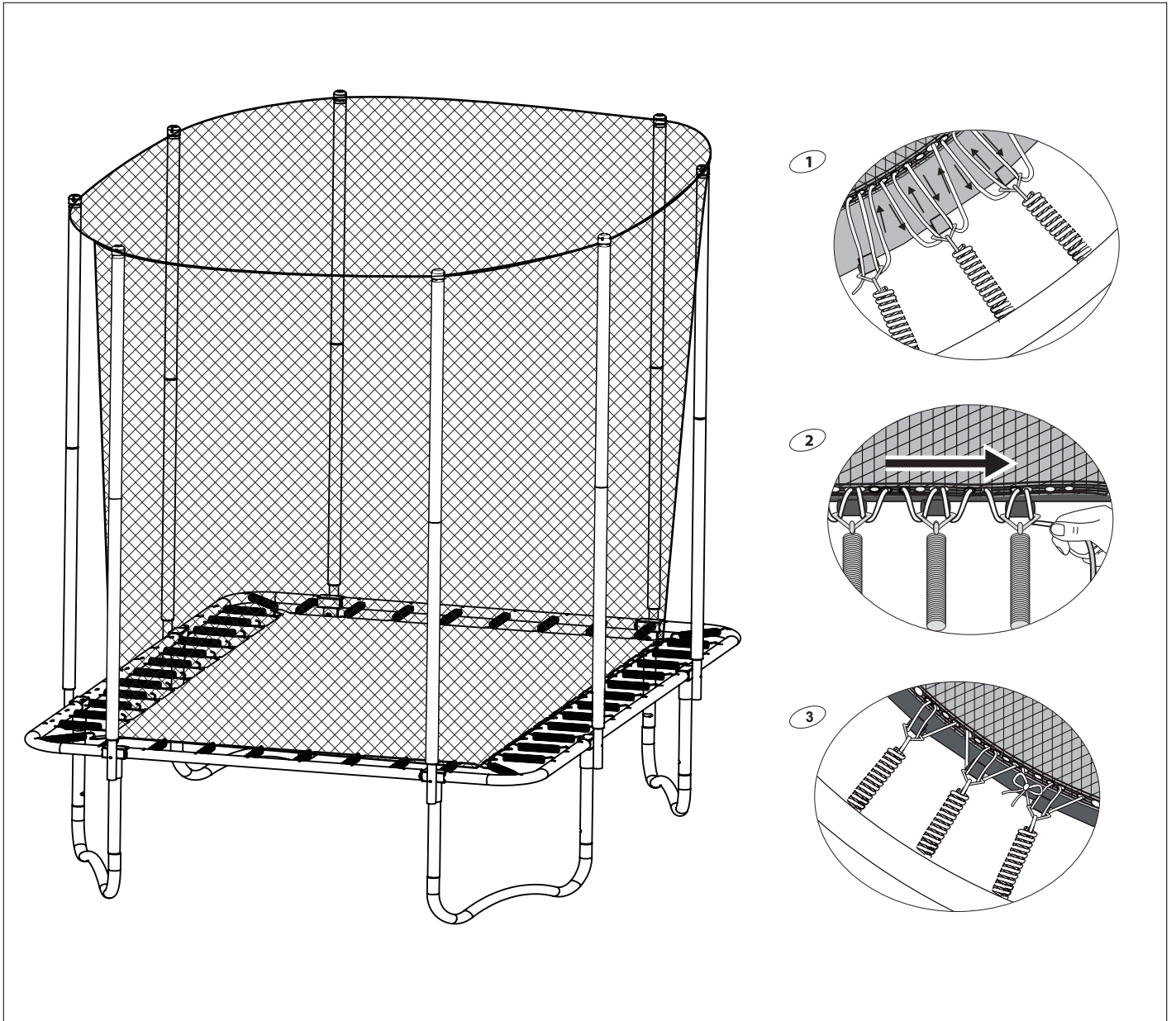

Figure 11



Step 6 Frame pad assembly

Connect the 2 half pads by touch fasteners and then attach the frame pad(8) to top rail with hook go through the jumping mat(7) triangle ring and band ties to the triangle hook as figure 12 shows.

Figure 12

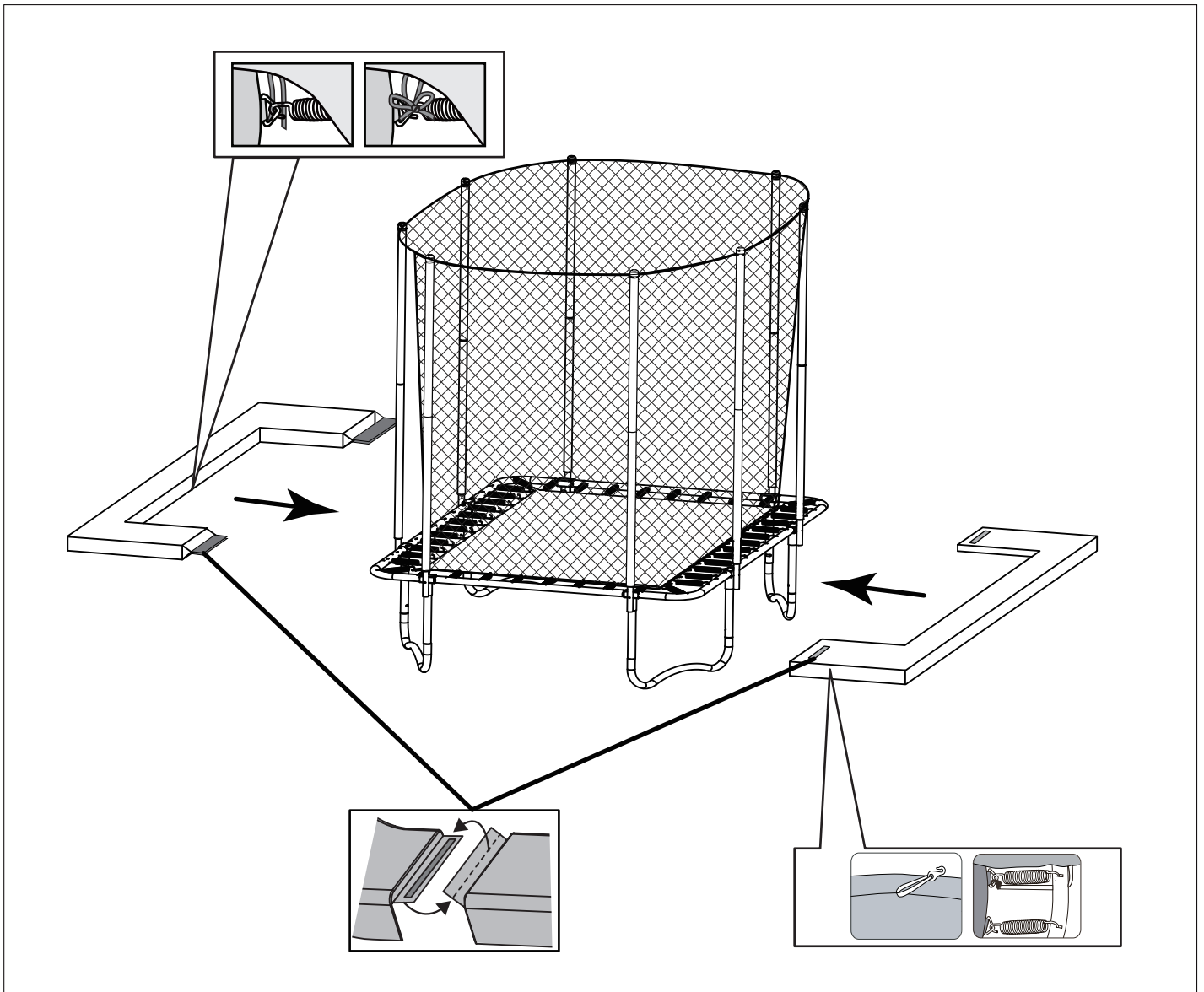

Step 7 Ladder Assembly

Put two horizontal ladder tubes (18) on the vertical ladder tubes (19) then fix two tubes with M6*55mm screw set (20), repeat the screw fixing four times as Figure 13 shows to get ladder assembled.

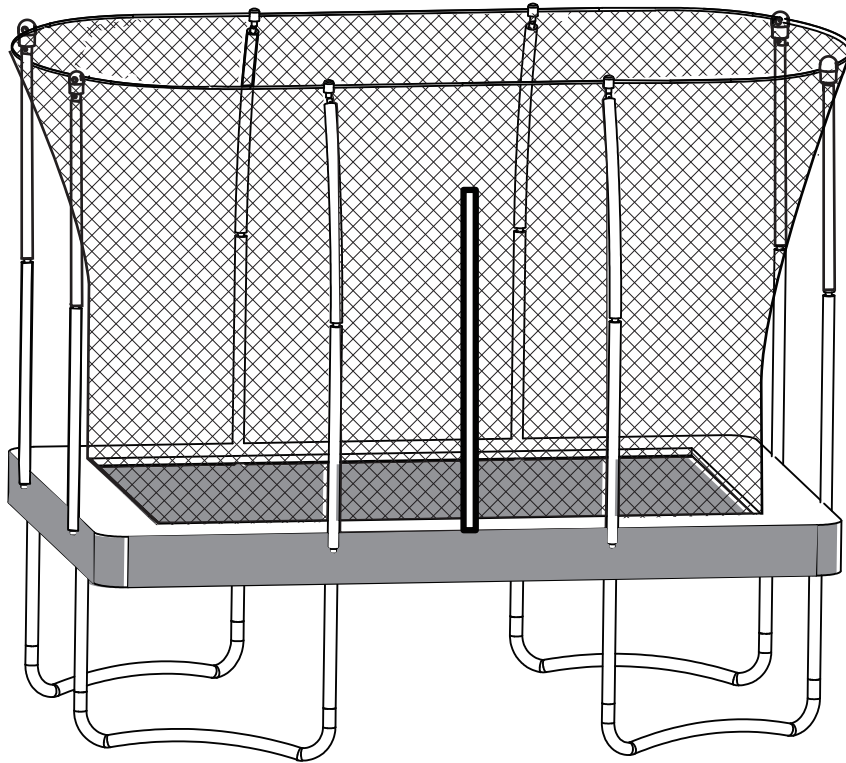
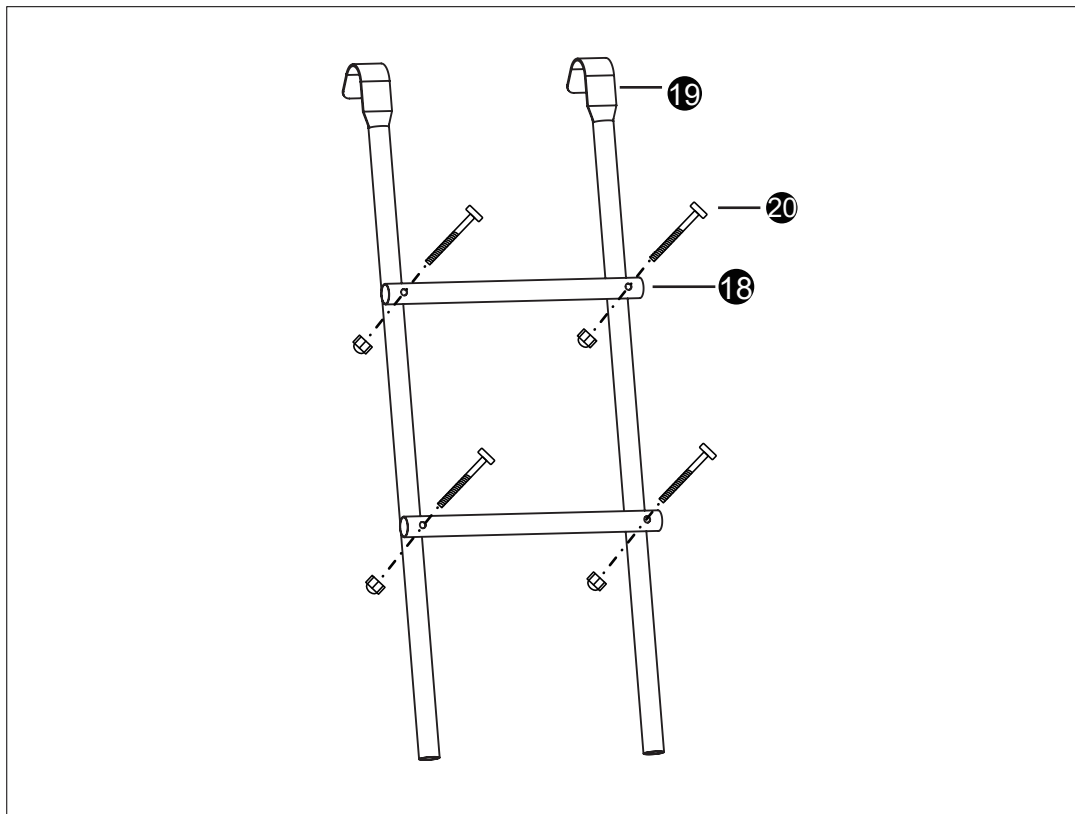
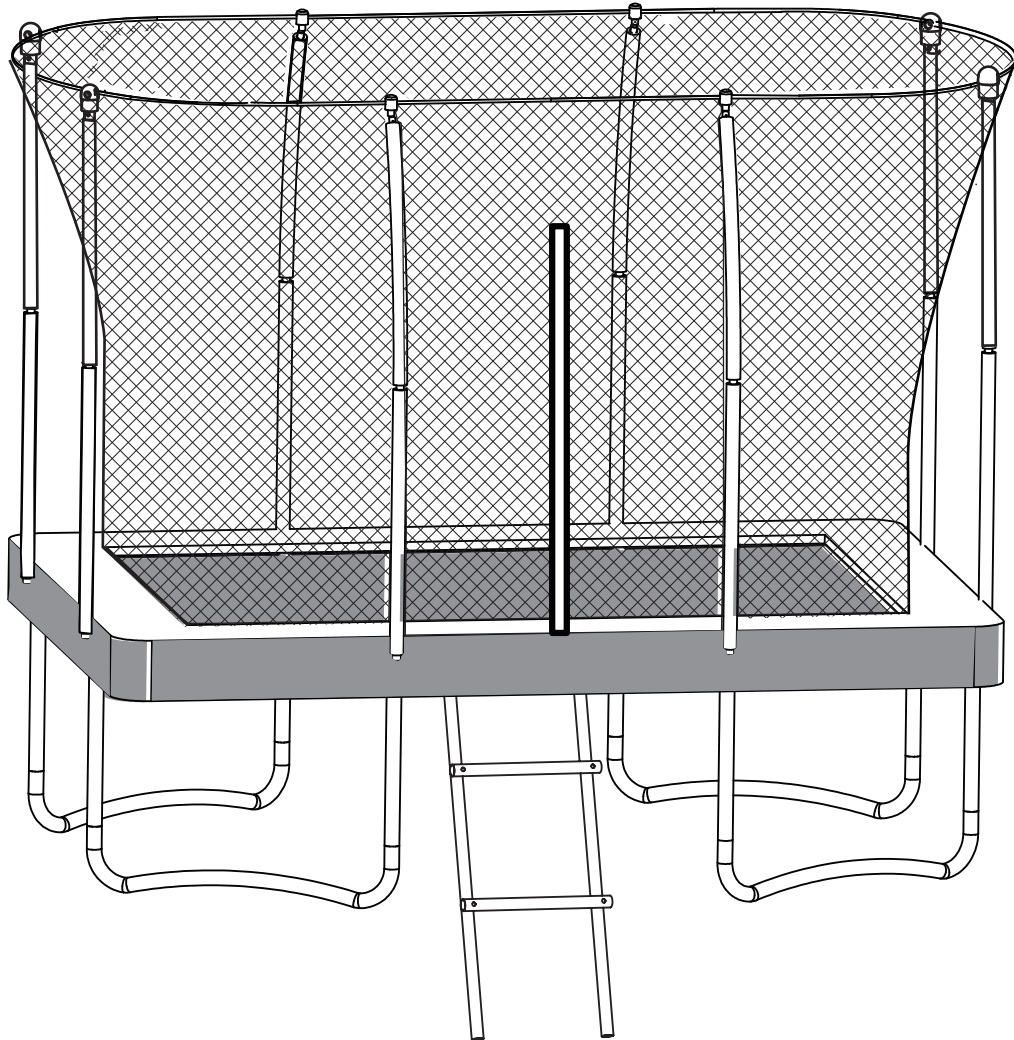

Figure 13





! IMPORTANT

Once you have finished the assembly of the trampoline, go back over all the nuts and bolts and properly tighten all of them before using.

Read this entire manual and make sure all jumpers completely understand all of the safety rules printed in the manual and on the various warning signs. Ensure that if the trampoline is moved it is positioned on a flat level surface with correct clearance distance. If you need to disassemble the trampoline, please follow the assembly instructions in reverse and take special care to retain all parts. Retain the original packaging for transport purposes.

WARNING!

In addition to the instructions and precautions provided with your trampoline, the following precautions must be observed while using the Trampoline Safety Enclosure.

- The metal frame of the trampoline enclosure will conduct electricity. Lights, extension cords, and all such electrical equipment must never be allowed to come in contact with the enclosure.
- Inspect the enclosure before each use. Make sure the straps and all parts are correctly and securely positioned and attached. Tighten any loose hardware. Replace any worn, defective, or missing parts.
- Wear comfortable clothing free of hooks, snaps, drawstrings or anything which can catch in the safety enclosure mesh. Remove jewellery, necklaces, and earrings.
- Climb on and off the trampoline only through the safety enclosure entrance and securely close entrance. Users, especially children, must not attempt to enter or exit between the trampoline frame and the enclosure. Doing this may pose a strangulation risk.
- Do not touch or rebound off the safety enclosure mesh while using the trampoline.
- Read all instructions and complete all assembly before using the safety enclosure.
- Use trampoline and trampoline enclosure only with mature, knowledgeable supervision.
- Adequate overhead clearance is essential. A minimum of 8 m from ground level is recommended. Provide clearance for wires, tree limbs, and other possible hazards.
- Lateral clearance is essential. Place the trampoline and trampoline enclosure away from walls, structures, fences, and other play areas. Maintain a clear space on all sides of the trampoline and trampoline enclosure. A minimum of six feet from frame edge is recommended.
- The trampoline is heavy and is under heavy tension. Three adults are required to set it up. Use appropriate clothing and shoes. Failure to follow these instructions may lead to injury or damage to the trampoline.
- Never set-up the trampoline in heavy rain, wind or storm conditions, especially lightning storms. It is recommended that the trampoline be taken apart and stored in bad weather.
- When moving the assembled trampoline, have at least four people evenly spaced around the frame (NSEW) to lift the trampoline off the ground.
- Place the trampoline and trampoline enclosure on a level surface before use.
- Use the trampoline and trampoline enclosure in a well-lit area. Artificial illumination may be required for indoor or shady areas.
- Secure the trampoline and trampoline enclosure against unauthorized and unsupervised use.
- Remove any obstructions from beneath the trampoline and trampoline enclosure.
- The owner and supervisors of the trampoline and trampoline enclosure are responsible to make all users aware of practices specified in the "Use Instructions".
- The trampoline enclosure is only to be used as an enclosure for a trampoline and the trampoline must be of the appropriate size covered by the specific enclosure.
- Do not allow more than one person on the trampoline or inside the trampoline enclosure. Use by more than one person at the same time can result in serious injuries.
- Trampoline is not allowed for children under six years of age.
- Inspect that trampoline and trampoline enclosure before each use. Make sure that frame cover, barrier and, enclosure support padding are correctly and securely positioned. Replace any worn, defective, or missing parts.

WARNING!

- The metal frame of the trampoline will conduct electricity. Lights, extension cords, and all such electrical equipment must never be allowed to come in contact with the trampoline.
- Wear comfortable clothing. Remove jewelry, necklaces, and earrings. Wear clothing free of draw strings, hooks, loops or anything that could get caught in the barrier.
- Enter and exit the enclosure only at the enclosure door or barrier opening designated for that purpose. It is a dangerous practice to jump from the trampoline to the ground or floor when dismounting, or to jump onto the trampoline from the ground. Do not use trampoline as a springboard to other objects.
- Avoid bouncing too high. Stay low until bounce control and repeated landing in the centre of the trampoline can be accomplished. Control is more important than height.
- Properly secure the trampoline when not in use. Protect it against unauthorised use. If a trampoline ladder is used, the supervisor should remove it from the trampoline when leaving the area to prevent unsupervised access by children under six years of age.
- For additional information concerning the trampoline equipment, contact the manufacturer.
- Read all instructions before using the trampoline and trampoline enclosure. Warnings and instructions for the care, maintenance, and use of this trampoline and trampoline enclosure are included to promote safe, enjoyable use of this equipment.
- Do not intentionally bounce off the barrier.
- Do not attempt to jump over barrier or attempt to crawl under barrier.
- Do not hang from, kick, cut or climb on barrier.
- Do not attach anything to the barrier that is not a manufacturer approved accessory or part of the enclosure system.
- Do not use the trampoline without mature, and knowledgeable supervision.
- Do not attempt or allow somersaults.
- Do not allow more than one person on the trampoline at any time.
- Do not use the trampoline when wet.
- Do not jump onto or off the trampoline.
- Do not use a trampoline while under the influence of alcohol or drugs.
- Do not allow any activity underneath the trampoline.
- Inspect the trampoline before each use. Make sure the frame padding is correctly and securely positioned. Replace any worn, defective, or missing parts.
- Keep objects away which could interfere with the user. Maintain a clear area around, above, and under the trampoline.
- Learn fundamental bounces and body positions thoroughly before trying more advanced skills.

For Recreational Use ONLY

Not for Professional Use.

Weight Limit for Trampoline User is 100kgs (220lb).

MAINTENANCE

Inspect the trampoline and trampoline enclosure before each use and replace any worn, defective, or missing parts.

The following conditions could represent potential hazards:

1. Missing, improperly positioned, or insecurely attached frame padding, barrier or enclosure support system (frame) padding and pole caps.
2. Punctures, frays, tears, or holes worn in the bed or frame padding, barrier or enclosure support system (frame) padding and pole caps.
3. Deterioration in the stitching or fabric of the bed or frame padding, barrier or enclosure support system (frame) padding and pole caps.
4. Ruptured springs or bands.
5. A bent or broken frame or support system.
6. A sagging barrier or bed.
7. Sharp protrusions on the support (frame) or suspension system.
8. Loosened or missing hardware.

(a) Components of this trampoline are susceptible to deterioration from use and environmental conditions, such as sunlight, rain, salt and heat, to varying degrees. It is essential that you inspect the trampoline before each use and replace any worn, defective, or missing parts before further use. Use only parts that are recommended by the manufacturer.

(b) The information contained in Table A1.

**TABLE A1
POTENTIAL HAZARDS OF TRAMPOLINE COMPONENTS**

Trampoline frame	Trampoline bed	Frame-padding (where required)	Enclosure system
Bending or breakage of the frame	Punctures, frays, tears or holes in the bed or edge system	Missing, improperly positioned or insecurely attached frame-padding	Missing, improperly positioned, or insecurely attached:
Broken, stretched or missing springs	Deterioration in the stitching or fabric of the bed or edge system	Punctures, frays, tears, or holes in the frame-padding	(a) Barrier. (b) Barrier supports. (c) Pole caps.
Sharp protrusions on the frame	Sagging of the bed	Deterioration of the stitching or fabric of the frame-padding and/or its securing system	Punctures, frays, tears, or holes in the barrier
	Sharp protrusions in the suspension system elements	Damaged or degraded padding	Damage to the support pole padding (when padding is required) Deterioration in the stitching or fabric of the barrier Sagging of the barrier Bent or broken barrier supports Sharp protrusions on the barrier support structure Broken or damaged enclosure entry system

NOTE: A sample inspection checklist for consumers is provided in Appendix B.

EXERCISE INSTRUCTIONS

FUNDAMENTAL BOUNCES

STANDING BOUNCE



1. Start in the centre of mat, with feet shoulder width apart, arms at side.
2. As you jump from trampoline, arms come up and forward, circling outward and back. To side as you again contact the mat. Bring feet together, toes pointed, in the air, feet shoulders-width apart again as you contact mat. Arms need never go above your shoulders or behind your body.

KNEE BOUNCE



1. First, assume kneeling position in centre of mat, back straight, eyes looking directly forward.
2. Pump your way to your feet by bouncing, using your arms as in standing bounce.
3. Duplicate position from a low bounce

HANDS & KNEE DROP



1. First, assume position shown in illustration, keeping head up, eyes looking forward.
2. Duplicate position from a low bounce. Keep your hands as close to your knees as shown in illustration.

FRONT DROP



1. First, assume position of hands and knees bounce. Begin to bounce slightly in this position, then kick legs back, land on stomach, taking some weight on bent fore arms as shown in illustration. Make sure you kick backwards, do not go forward and return to hands and knees position.
2. Try from a low bounce, kicking backwards, making your belt land where your feet were

SEAT DROP



1. First, assume sitting position in centre of mat, legs spread wide, and hands on mat, leaning slightly forward.
2. Duplicate this position from a low bounce to come to your feet again, be sure to lean forward and press mat with your hands.

EXERCISE INSTRUCTIONS

BACK DROP

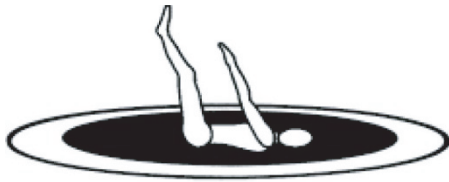

1. Lie on your back on mat, spread your legs slightly and raise them about 45 degrees from the surface of the mat, raise your arms to corresponding angle, raise head and look at end of trampoline. This is your landing position.
2. Try cautiously from a low bounce, making sure you do not lose sight of end bar of trampoline at any time. Weight should be taken more on your shoulders than on your hips.

PIROUETTE



HALF PIROUETTE:

Done like a standing bounce, but **at top of bounce**, swiftly turn head and search for opposite end of trampoline. Do not travel. Land on feet.

FULL PIROUETTE:

Done as above, but continue around, until a complete circle has been made. Spot by looking for end bars as you complete trick

TUCK POSITION



Done like a standing bounce, but **at top of bounce**, bring knees to chest and grasp with arms. Then lower feet to contact mat.

PIKE POSITION



Done like a standing bounce, but **at top of bounce**, keeping knees locked and toes pointed, raise legs as illustrated, then lower feet to contact mat.

LAYOUT POSITION



Done like a standing bounce, but **at top of bounce**, stretch slightly, arching back, and momentarily looking skyward.

STRADDLE POSITION



Done like pike bounce, but with legs spread as widely as is comfortable. Reach for your toes!

CLEANING

Do not use any abrasive cleansers for the cleaning. Use a soft, damp cloth to eliminate dirt and dust.

DISPOSAL ADVICE

Packaging:

This product is delivered with packaging to protect it from damages during transport. The packaging materials are made of raw materials which are recyclable. Please dispose of these materials according to material type.

If you want to dispose of the products, dispose according to regulations in your area. Refer to your municipal institution for further information.

CUSTOMER SERVICE:

Name: JCA Collective

Email: service@jcacollective.com

Phone Number: +61 423 259 751

Office Hours: Monday to Friday 9am to 5pm

Keycode:43062706

PO number:

The date of purchase:

The components will deteriorate over time.

Product Warranty

This product is warranted to be free from defects in material and workmanship under normal use and service conditions for ninety (90) days after the date of purchase. The frame on trampolines is warranted for two (2) years after the date of purchase.

All warranty coverage extends only to the original purchaser of the product and is not assignable or transferable. The original store or online purchase receipt must be kept as proof of purchase in order for the warranty to be valid. These documents must be presented in the event of making a warranty claim.

During the warranty period, we will provide repair or replacement of defective equipment or parts thereof covered by the warranty. Any handling transportation, delivery and other incidental charges in respect of the servicing of the equipment shall be borne by the Purchaser. If the product includes a number of accessories, only the defective part or accessory will be replaced.

The warranty will become void if any defects or damages are associated with the use of unauthorized replacement parts. All replacement parts must be obtained from our authorized agents.

All decisions made by the manufacturer in respect of the servicing of the equipment (including repairs, replacements or issues relating to defects of workmanship or materials) shall be conclusive and the Purchaser agrees to be bound by such decisions. Any defective equipment or part thereof replaced shall become the property of the manufacturer.

In the event of a product or accessory being replaced during the guarantee, the guarantee on the replacement will expire at the original date, i.e. 90 days from the original purchase date.

This warranty excludes defects caused by the product not being used in accordance with instructions, accidental damage, misuse or being tampered with by unauthorized persons.

This Limited Warranty does not cover:

- a) Products used for commercial or rental purposes.
- b) Loss or damage to product due to:
 - i. Abuse, repairs and/or tampering by any person other than our authorized personnel.
 - ii. Negligence and/or misuse (including foreign objects, accidents, improper storage, exposure to sun/moisture, excessive temperature, sand, dust, dirt, other pollution or other environmental conditions and failure to follow precautions or proper operating instructions stated in the User's Manual such as improper installations)
 - iii. Fire, flood, lightning strike, wind storm or other acts of God
 - iv. Freight or improper transport damages
 - v. Improper usage (including use by underage, overweight or excessive number of users permitted as stated in the User's Manual).
- c) Defects, damages or accidents due to the malfunction, connection to or use of unauthorized parts.

In such event, we reserve the right to cancel the Limited Warranty coverage immediately.

To the extent allowed by the applicable local law, the remedies in the Limited Warranty are the Purchaser's sole and exclusive remedies.

Our goods come with guarantees that cannot be excluded under the Australian Consumer Law. You are entitled to a replacement or refund for a major failure and compensation for any other reasonably foreseeable loss or damage. You are also entitled to have the goods repaired or replaced if the goods fail to be of acceptable quality and the failure does not amount to a major failure.

For New Zealand customers, this warranty is in addition to statutory rights observed under New Zealand legislation.

THE MANUFACTURER IS NOT RESPONSIBLE OR LIABLE FOR INDIRECT, SPECIAL OR CONSEQUENTIAL DAMAGES ARISING OUT OF OR IN CONNECTION WITH THE USE OR PERFORMANCE OF THE PRODUCT OR OTHER DAMAGES WITH RESPECT TO ANY ECONOMIC LOSS, LOSS OF PROPERTY, LOSS OF REVENUE OR PROFITS, LOSS OF ENJOYMENT OR USE. COST OF REMOVAL, INSTALLATION OR OTHER CONSEQUENTIAL DAMAGES.

THE WARRANTY EXTENDED HEREUNDER IS IN LIEU OF ALL OTHER WARRANTIES AND ANY IMPLIED WARRANTY OF MERCHANTABILITY OR FITNESS FOR A PARTICULAR PURPOSE IS LIMITED IN ITS SCOPE AND DURATION TO THE TERMS SET FORTH HEREIN.

PLEASE NOTE: ANY REPAIRS OR REPLACEMENTS MUST BE MADE USING MANUFACTURER AUTHORIZED PARTS IN ORDER FOR THIS WARRANTY TO BE VALID.

DO NOT RETURN PRODUCT TO THE STORE. PLEASE CONTACT OUR CUSTOMER SERVICE FOR PARTS OR ASSEMBLY INSTRUCTIONS. STORES ARE NOT EQUIPPED TO PROVIDE CUSTOMER SERVICE FOR THIS PRODUCT.

CUSTOMER SERVICE:

Name: JCA Collective

Email: service@jcacollective.com

Phone Number: +61 423 259 751

Office Hours: Monday to Friday 9am to 5pm

Keycode:43062706

PO number:

The date of purchase:

The components will deteriorate over time.

