

Kmart Balance bike Instruction Manual

Keycode: 43094868

Congratulations in purchasing Kmart balance bike. The aim of the balance bike is to assist in the development of your child's balance, coordination and steering, as well as to build strength and motor skills. Your child will be able to learn how to ride with ease. Please pay attention to the following safety guidelines.

Important Safety Information:

1. Recommended for children 2 to 5 years.
2. Check all parts are in good condition and that screws and tyres are tightened correctly.
3. Protective gear should always be worn when riding any bike (helmet, protectors for knees, elbows and wrists).
4. Always ensure that appropriate footwear is worn whilst riding this bike.
5. Maximum weight is 20 kg.
6. Only one person to ride this bike at any given time.
7. This bike is not intended for stunting or tricks.
8. Do not use on roadways, always ride in a safe environment such as a park or private property.
9. This balance bike is not constructed for uneven paths, stairs, steep hills, or other rocky surfaces. Damage may be done to the bike and to the rider. Only use on flat surfaces.
10. Adult supervision is required at all times.
11. Check the child's feet can rest on the ground whilst astride the balance bike by adjusting the seat height before allowing child to ride this bike.

Contents of the package

Note! Certain bike parts, like the frame, saddle and two screws with nuts were pre-assembled in factory. Check if the package is complete and does not show any traces of damage. Should you find some parts missing or damaged, do not use the bike but contact the seller. Keep the packaging or utilize it as required by the local regulations. Caution! For the safety of kids do not leave parts of the packaging (plastic bags, blisters, boxes, styrofoam etc.) freely available. Risk of suffocation!

Cleaning and maintenance

- Clean the bike with a damp cloth or sponge.
- Protect the run bike from dust, humidity, water, extremely high and low temperatures, damage etc.

WARNING: Item to be assembled by adult only. Choking hazard, contains small assembly components with functional sharp points and edges.

PART LIST

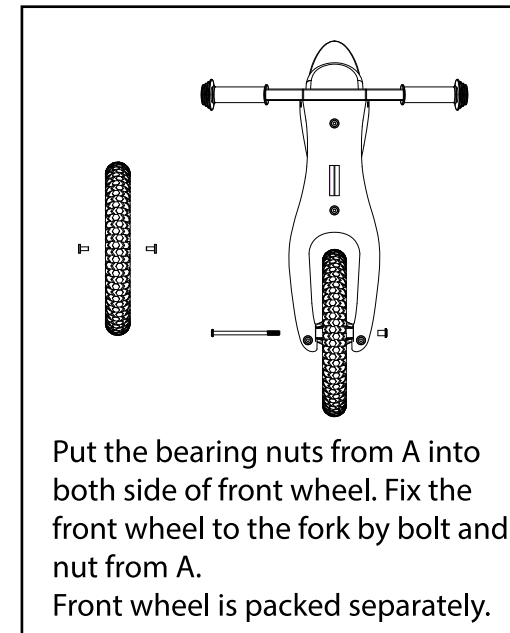
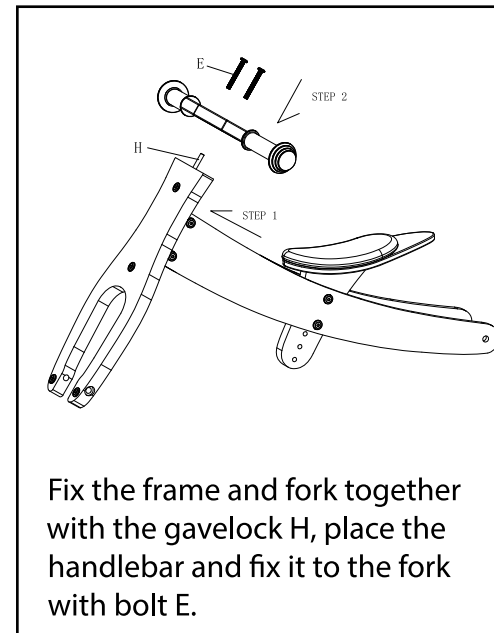
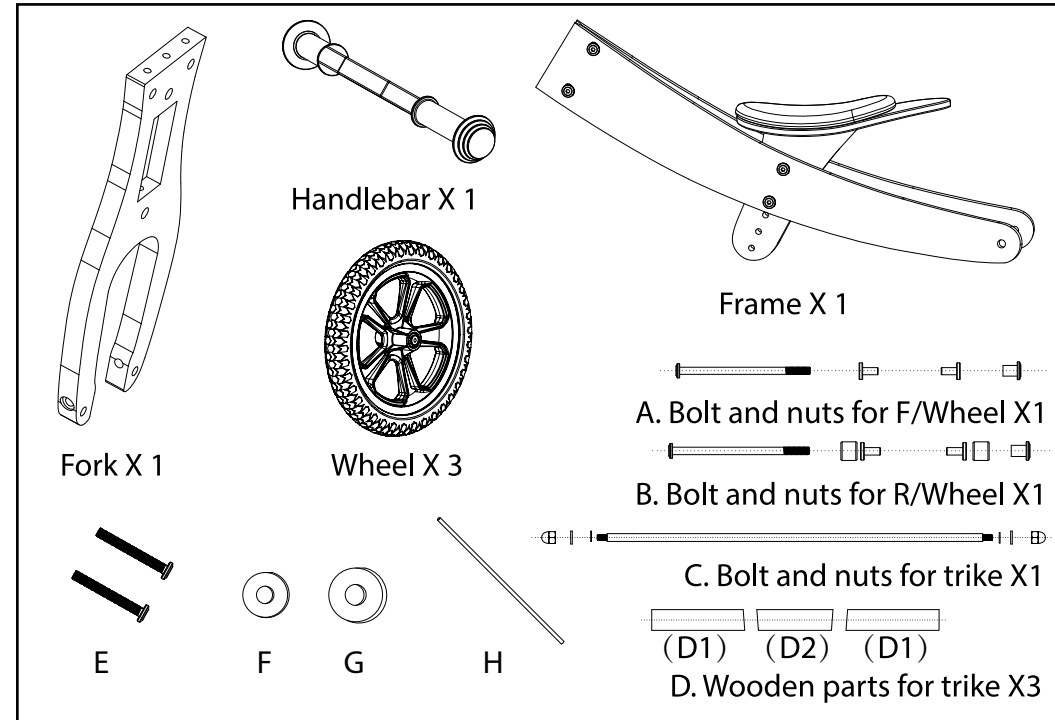

Option I: TRIKE

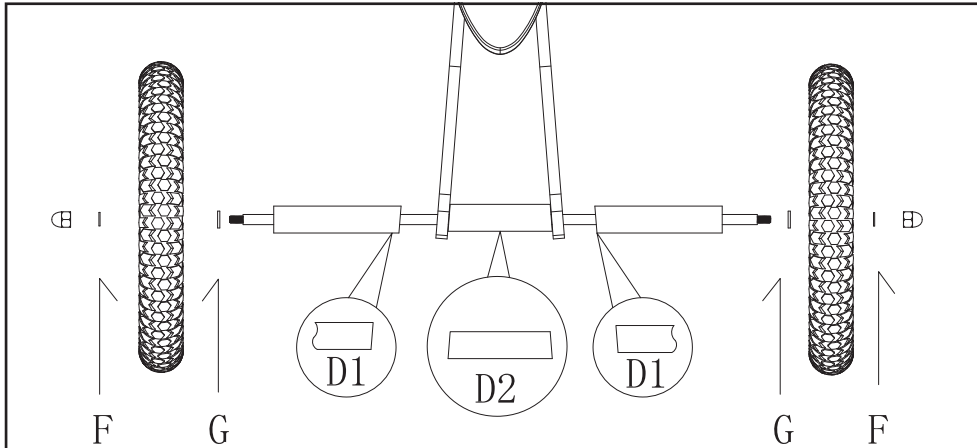

Fix the rear wheel with bolt set C and wooden spacer D. Pay special attention to the difference of wooden spacer D2. Place the wooden spacer D1 with angular face towards the frame. The Thinner washer F with 6mm Dia. is used outside with cap nut.

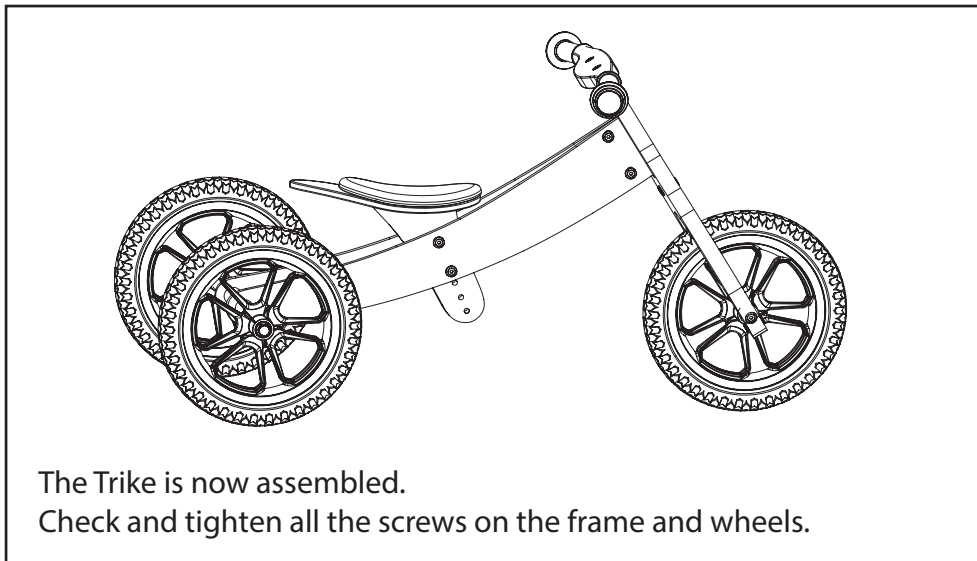

The Trike is now assembled. Check and tighten all the screws on the frame and wheels.

ATTENTION: This Trike can also convert to a balance bike when your child leans to keep balance himself. See the assembly details on next page.

Option II: BALANCE BIKE

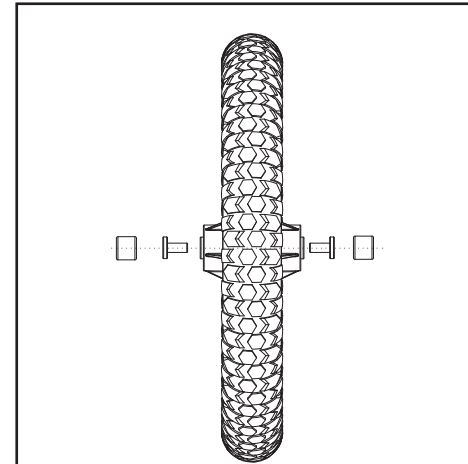

Insert the bearing Nut from B into both sides of Rear Wheel. The White plastic spacer is to be placed between the wheel and frame.

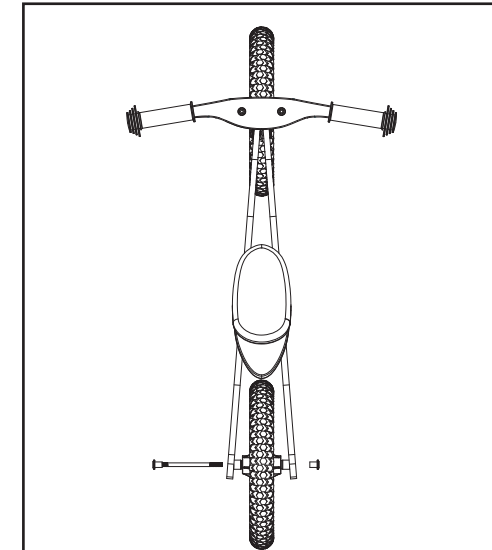

Fix the rear wheel with bolt and nut from B.

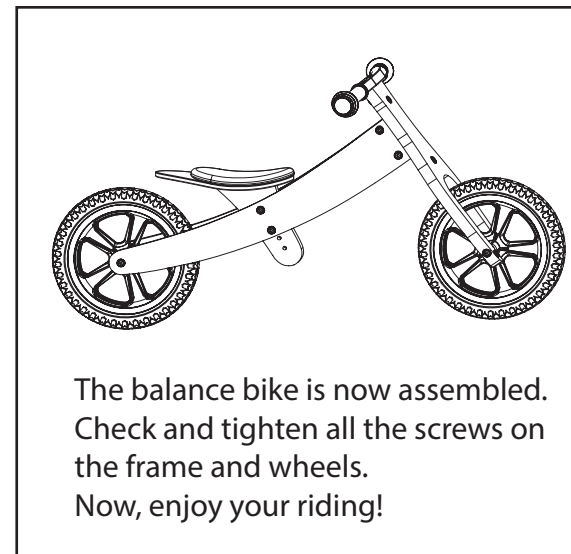

The balance bike is now assembled. Check and tighten all the screws on the frame and wheels. Now, enjoy your riding!

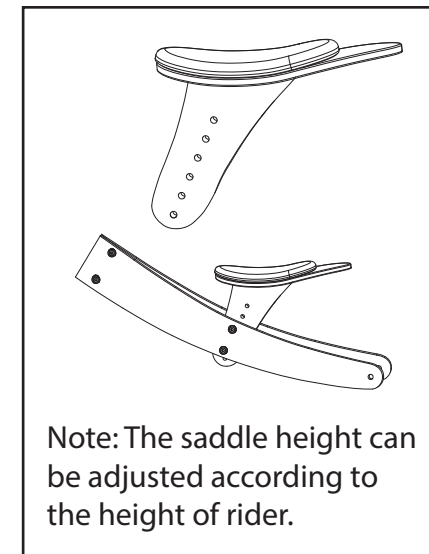

Note: The saddle height can be adjusted according to the height of rider.