

BACK COVER
14.85cm

FRONT COVER
14.85cm

anko

Adjustable Height Co-Sleeper Instruction Manual

0-6
months

9
kg

MAXIMUM
WEIGHT OF CHILD



The illustrations shown in this manual are for reference only. The manufacturer reserves the right to change any specification or feature without further notice.

**IMPORTANT! PLEASE READ CAREFULLY BEFORE USE AND KEEP
FOR FUTURE REFERENCE.**

21cm

KEYCODE: 43-096-732

MADE IN CHINA

FOR AU / NZ: IMPORTED FOR KMART
STORES IN AUSTRALIA AND NEW ZEALAND.

KMART CUSTOMER SERVICE
AU: 1800 124 125 NZ: 0800 945 995

WARNING:

- Read all instructions before assembling and using the product.
- Assemble product according to manufacturer's instructions for EACH of the uses (co-sleeper or bassinet).

 **WARNING:** This product is designed for babies aged between 0 to 6 months, weighing up to a maximum of 9kgs.

 **WARNING:** The Adjustable Height Co-Sleeper must be placed on a horizontal floor. Never leave the product on an inclined surface with the child inside of it.

 **WARNING:** Children should not be allowed to play unsupervised in the vicinity of Adjustable Height Co-Sleeper.

 **WARNING:** The Adjustable Height Co-Sleeper should be locked in the fixed position when the child is unsupervised.

 **WARNING:** Refer to the instruction manual and follow the assembly steps. Ensure all assembly fittings are tightened properly and care should be taken to ensure no screws are loose as a child could trap parts of their body or clothing (e.g. strings, necklaces, ribbons for babies' dummies, etc.), which could pose a risk of strangulation.

 **WARNING:** Do not use the Adjustable Height Co-Sleeper if any part is broken, torn or missing.

 **WARNING:** When a child is able to sit up unaided, kneel or pull itself up, the Adjustable Height Co-Sleeper should no longer be used for this child.

WARNING:

 **WARNING:** All instructions must be followed as **SERIOUS INJURY OR DEATH COULD OCCUR.**

 **WARNING:** Not to use the product without its frame.

 **WARNING:** The thickness of the mattress chosen shall be such that the internal vertical height (surface of the top of the mattress to the upper edge of the bed sides) is at least 200mm in the highest position of the bed base.

 **WARNING:** Only use the mattress provided. Other mattresses sold separately may not be suitable for the Adjustable Height Co-Sleeper and result in harm to the child.

 **WARNING:** Be aware of the risk of open fires and other sources of strong heat, such as electric bar fires, gas fires, etc. near the vicinity of the child.

 **WARNING:** Never leave infant unsupervised in bassinet with both sides down.

 **WARNING:** Do not use the product for more than one child at a time.

 **WARNING:** A bedside sleeper is designed to provide a sleeping area for an infant until he or she begins to push up on hands and knees or approximately 5 months of age. Move your child to another sleeping product when your child reaches this stage.

 **WARNING:** Check tightness before each use by pulling bedside sleeper in a direction away from adult bed.

WARNING:

FAILURE TO FOLLOW THESE WARNINGS AND THE INSTRUCTIONS COULD RESULT IN SERIOUS INJURY OR DEATH. DO NOT USE THIS PRODUCT IF YOU CANNOT PRECISELY FOLLOW THE INSTRUCTIONS THAT COME WITH IT. THIS PRODUCT SHOULD BE FULLY ASSEMBLED TO USE.

Suffocation Hazard:

- Infants have suffocated: In gaps between extra padding and side of the bassinet, and on soft bedding.
- Do not use any extra padding material.
- Use only the mattress provided by the manufacturer.
- Never add a pillow, comforter, doona, sheets, bedding or another mattress for padding.
- If using a sheet with the mattress, please ensure that this is the correct size.
- FAILURE TO FOLLOW THIS WARNING COULD CAUSE A SUFFOCATION HAZARD

WARNING:

Entrapment Hazard:

- To prevent death from entrapment, the co-sleeper must be properly secured to adult bed using the attachment anchors.
- There must be no more than a 13mm gap between the co-sleeper and the adult bed.

UNSUPERVISED SLEEPING OF INFANTS UNDER ONE YEAR OF AGE (OR WHEN BABY STARTS TO ROLL)

To reduce the risk of SIDS:

- Pediatricians recommend healthy sleeping positions where infants are placed on their backs to sleep, unless otherwise advised by your physician.
- To avoid serious harm, ensure there are not any loose fabrics around the baby to avoid suffocation when sleeping.
- Ensure the product is properly anchored and positioned before each use by pulling the co-sleeper away from the adult bed.
- If gap exceeds 13mm, DO NOT use product. Do not fill the gap with pillows, blankets or other items that can cause suffocation.
- Always read and follow assembly instructions for each product use (co-sleeper or bassinet).

Back Cover
14.85cm

Front Cover
14.85cm

! WARNING:

FALL HAZARD:

- To prevent falls, do not use this product when the infant begins to push up on hands and knees, is able to sit up unaided or has reached 9kgs, whichever comes first.
- Please use all required parts for each use (co-sleeper or bassinet). Check instruction manual for a list of required parts. Periodically check product for loose, damaged, or missing parts.
- DO NOT use product if any part is loose or missing, or if there are any signs of damage.
- DO NOT substitute parts. Contact Kmart Customer Service if replacement parts or instructions are needed.
- In Bassinet Mode, ensure that the side panel is locked. Strings can cause strangulation. NEVER place product near window blinds, patio doors or curtains with cords where a child could reach the cord and be strangled.
- DO NOT hang strings over the product, place items with a string around an infant's neck or attach strings to toys.
- DO NOT place any cord, strap or similar items in or near this product that could become wrapped around a child's neck.
- Strings can cause strangulation. DO NOT leave anything with a string inside the product, such as hood strings or pacifier cords.
- DO NOT attach strings to toys. DO NOT suspend strings over the Adjustable Height Co-Sleeper.

NEVER USE THIS PRODUCT IN CO-SLEEPER MODE WITHOUT THE FIXING BELTS SECURELY ATTACHED TO THE ADULT BED

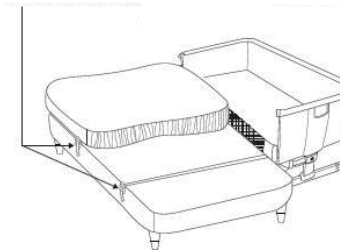

CORRECT BED AS FRAME IN LINE



INCORRECT BED AS MATTRESS, BOX SPRINGS & FRAME NOT IN LINE

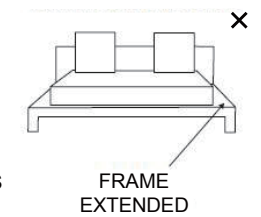

SUFFOCATION, ENTRAPMENT AND FALL HAZARDS:

- To use bassinet mode, ALWAYS raise the side with the zipper to completely close up all 4 sides.
- NEVER leave infant in bassinet unsupervised with the sides down.
- To use Co-Sleeper Mode, ALWAYS push adult mattress against bedside sleeper after securing to bed with safety strap.
- The co-sleeper is designed for use only with adult beds that are between 21.4"-25.5" (54.36 - 64.77cm) from floor to top of adult mattress. Do not use if the adult's bed width is more than 180cm.
- The fixing belts assembly must always be used in co-sleeper mode. Product in co-sleeper mode must be tightly attached to the adult bed mattress to ensure safety.
- It is recommended to make the straps shorter than the width of the mattress to ensure co-sleeper is pressed securely and tightly against the adult bed, without any gaps.
- Do not move the product with the child inside.
- To prevent trapping hazards, do not position the Adjustable Height Co-Sleeper near a wall.
- Do not leave any object inside the product that could reduce its depth.

Back Cover
14.85cm

Front Cover
14.85cm

COMPONENTS

Please check the contents listed below are included in the box when opened. If there are any missing parts, please contact Kmart Customer Service before using the product.

- A. Central supporting structure
- B. Middle support frame
- C. Fixing belts
- D. Mattress with removable fitted sheet
- E. Outer fabric lining
- F. Travel bag

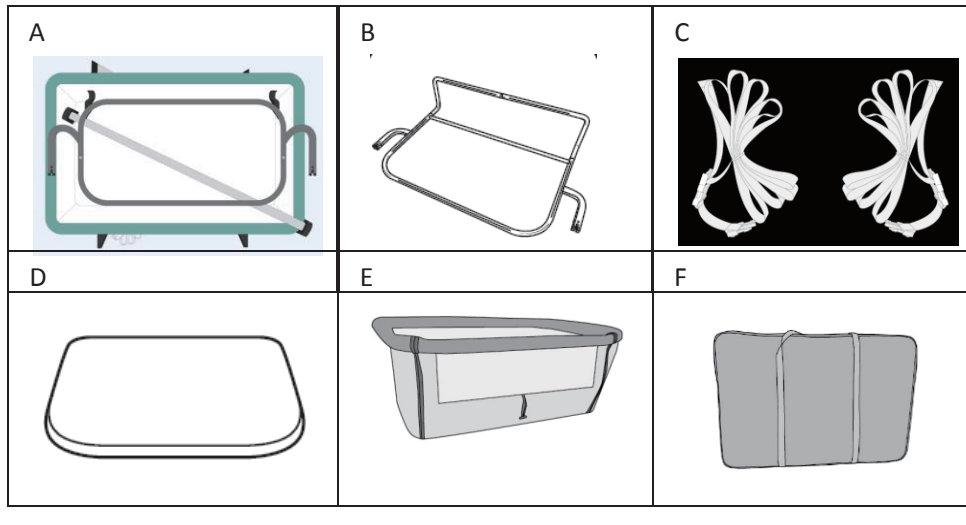

- A1. Height adjuster button
- A2. Middle support frame release button
- A3. Adjustable feet with wheels and brakes
- A4. Non-slip feet
- A5. Adjustable feet rotate button
- A6. Front bar release button

- B1. Fixing pin
- C1. Fixing male buckles
- C2. Belt length adjustment buckles
- E1. Belt with grip fastener
- E2. Zip for fabric removal
- E3. Zip for side panel opening
- E4. Mesh window
- E5. Side support for restraint

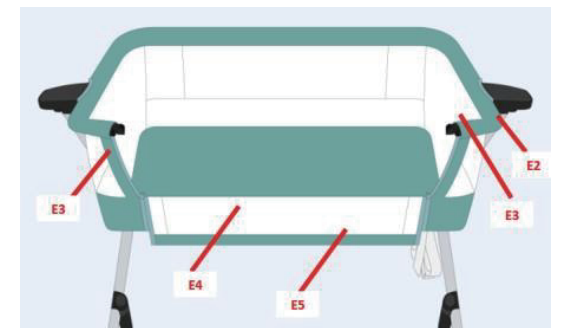
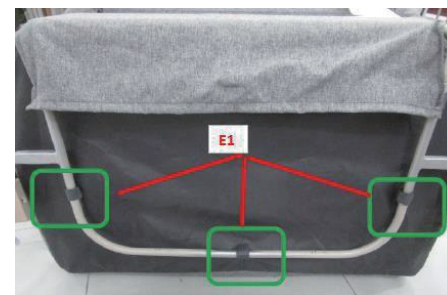
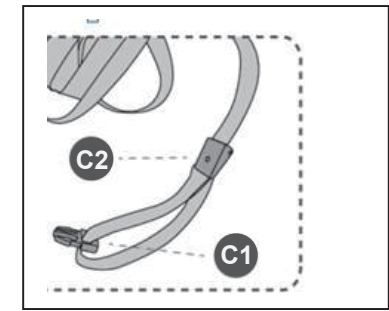
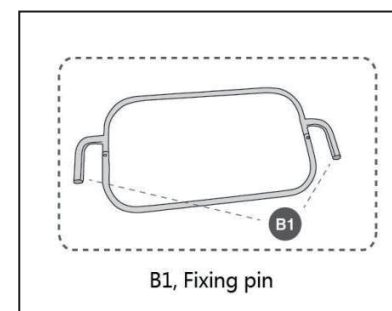
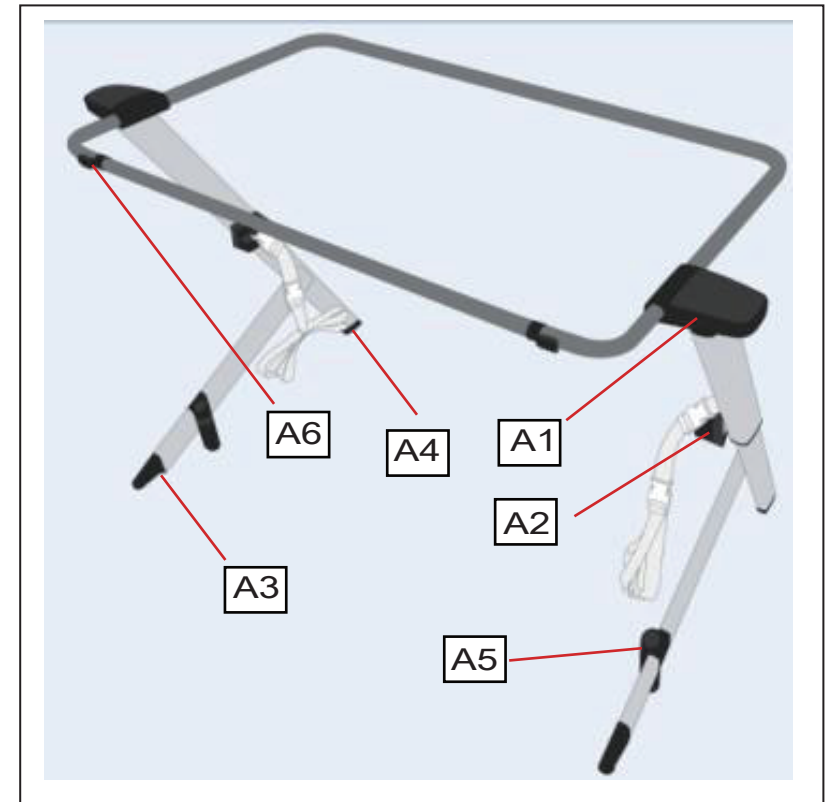

21cm

Back Cover
14.85cm

Front Cover
14.85cm

ASSEMBLING THE BASSINET

1. Take product from carton box. Hold the central supporting structure and turn the leg outward until you hear the locking "Click" sound on the top hinges. Repeat with the other leg as shown below.



2. Insert the side rail into the middle support frame by lining up the buttons and holes, until you hear a "Click" sound, as shown below.

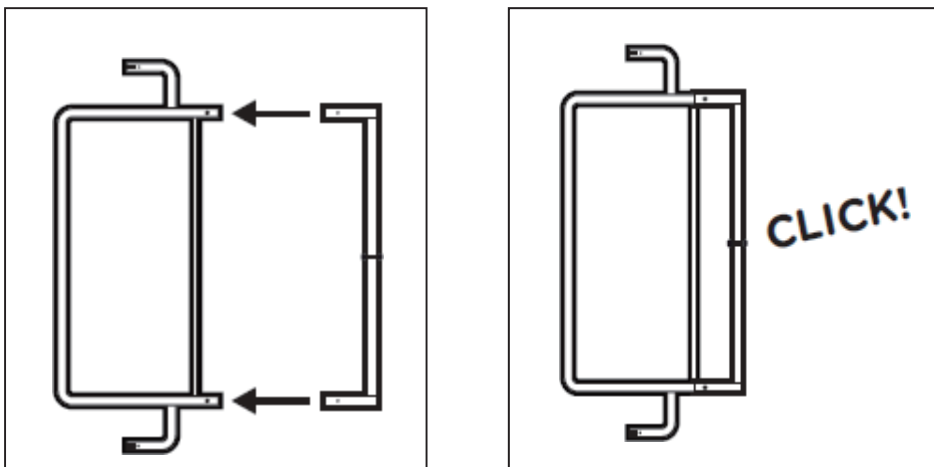

3. Turn the product upside down, insert the middle support frame gently into the side slots as per image, with curved bar facing down as shown below.

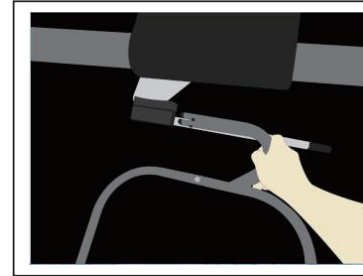

4. You will hear a "Click" sound once the frame locks into position. Ensure both sides are securely locked into place.

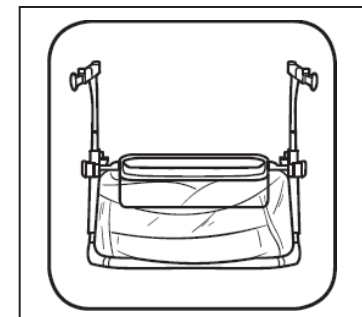
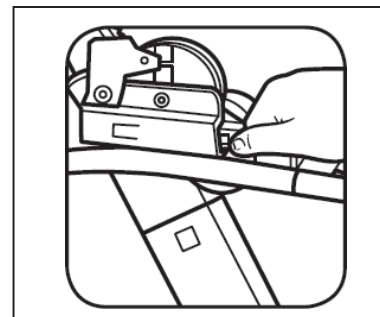

⚠ WARNING:

DO NOT use the Adjustable Height Co-Sleeper if any parts are missing, damaged or broken.

21cm

5. Turn the product in the upright position, insert the bassinet fixing steel bar into the tub slot on both sides of frame.

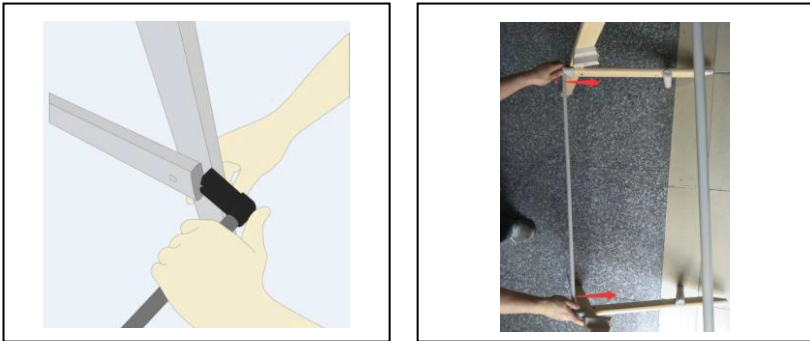

6. Fix the outer fabric lining to the central supporting structure. Hook the 2 belts at the bottom of the lining.

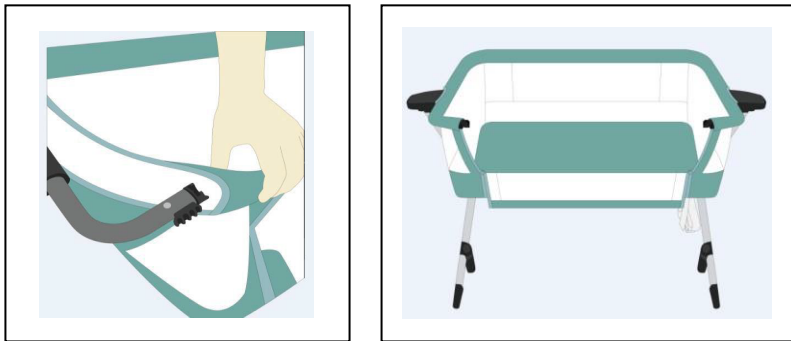

7. Fix the top rail on both sides and then zip up the front panel.

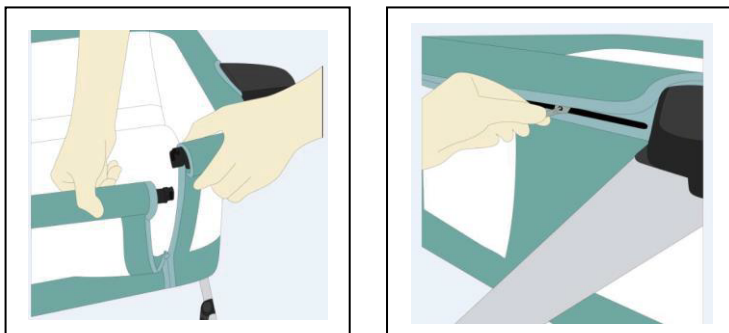

8. Lift side panel fabric over the side bar. Insert side bar into fabric pocket. Secure fabric to support frame with grip fasteners.

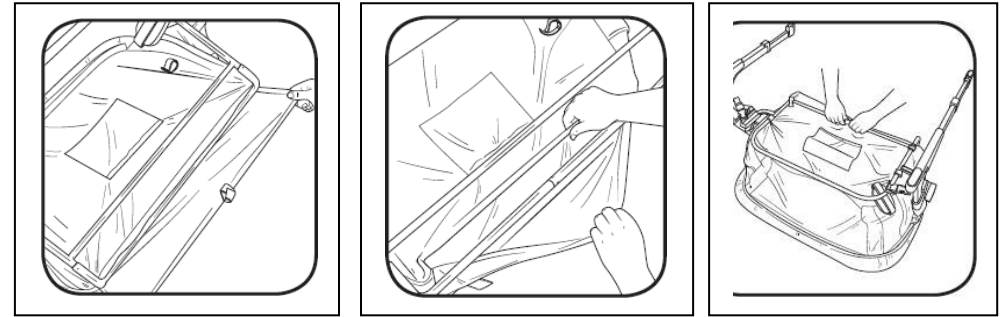

9. Place the mattress into the bassinet. The bassinet is now assembled.

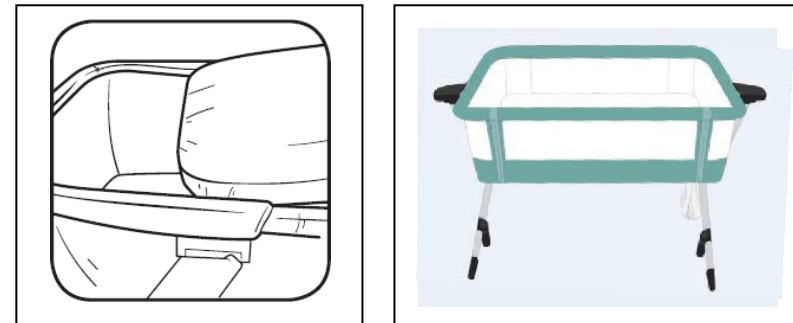

TO ADJUST THE HEIGHT

1. The Adjustable Height Co-Sleeper can be adjusted to 5 different height positions. In order to adjust the height, press the height adjuster buttons (A1) simultaneously on both sides of the cot to the desired position.

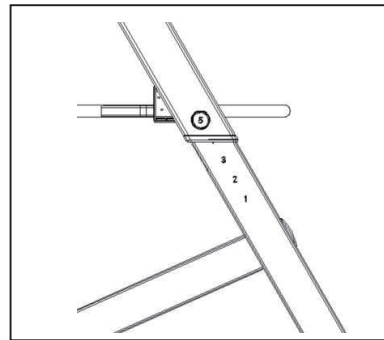
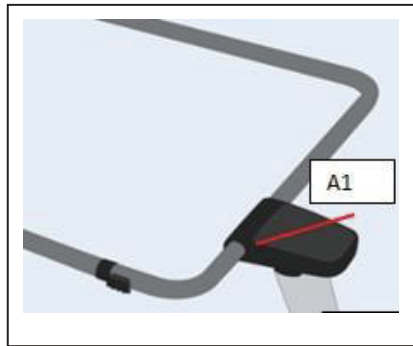

2. Ensure that both legs are positioned at the same height.

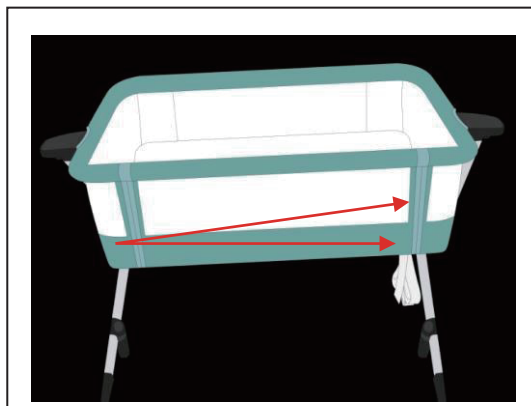

3. The Adjustable Height Co-Sleeper is designed for use only with adult beds that are between 21.4"-25.5" (54.36 - 64.77)cm from the floor to the top of the adult mattress. Please do not use if the adult's bed width is more than 180cm.

⚠ WARNING! - IMPORTANT FOR THE SAFETY OF YOUR CHILD:

THIS METHOD IS ONLY COMPATIBLE WITH BED TYPES THAT COMPLY WITH ALL OF THE CONDITIONS DESCRIBED HERE:

- THE SIDE SUPPORT OF THE CO-SLEEPER SHOULD ALWAYS BE PLACED CLOSE TO THE ADULT MATTRESS.
- THE MATTRESS SHOULD ALWAYS BE ALIGNED WITH THE HEIGHT OF THE SIDE SUPPORT OF THE CO-SLEEPER.
- THE CO-SLEEPER SHOULD BE FIRMLY FIXED TO THE STRUCTURE OF THE ADULT BED OR TO THE MATTRESS SUPPORT.

⚠ WARNING!

CHECK TO ENSURE THAT THE BEDSIDE SLEEPER IN THE CO-SLEEPER MODE DOES NOT INTERFERE WITH THE ADULT BED.

⚠ WARNING!

DURING USE, ENSURE THAT THE ADULT BED SHEETS, BLANKETS ETC, DO NOT ENTER THE CO-SLEEPER AND COVER THE INTERIOR OF THE CO-SLEEPER. THIS CAN CAUSE SUFFOCATION.

CO-SLEEPER MODE (FIXING TO BED)

1. Unzip the sides of the co-sleeper until they are completely unzipped.

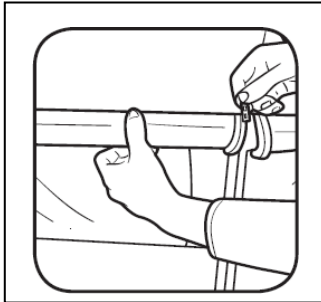

2. Slide the top bar lock lever away from the top bar and lift the top bar out of the groove on both sides and fold down.

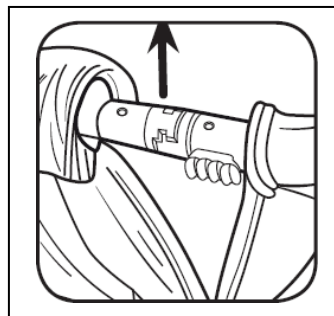
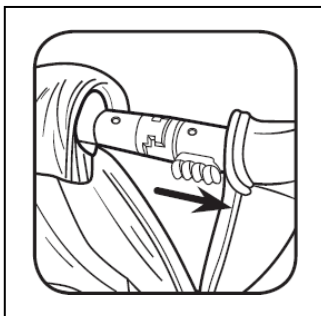

21cm

3. Move the beside sleeper close to the parent's bed and check the height of the bedside sleeper compared with that of the adult mattress. The side support of the sleeper should always be placed close to the adult mattress and the mattress should always be aligned with the height of the side support for restraint of the sleeper.
4. To avoid injury of the infant's neck from being caught on the top rail alongside the adult's bed, the top rail must be no higher than the adult bed mattress.

!WARNING!

IN THE CO-SLEEPER MODE, THE 2 LEGS OF THE BEDSIDE SLEEPER MUST ALWAYS BE ADJUSTED TO THE SAME HEIGHT.

5. In order to attach the bedside sleeper to the parent's bed in co-sleeper mode, use the fixing belts provided.
6. Slide the fixing belts between the top mattress and the base across the opposite side of the bed using a back and forth "swing" motion simultaneously pulling downward until the straps and fixing belts are in the desired position.

!WARNING!

ENSURE THAT THE FIXING BELTS ARE STRAIGHT.

Back Cover
14.85cm

Front Cover
14.85cm

7. Tighten the loops by pulling the belts firmly. Adjust the fixing belt straps separately until the bedside sleeper is firmly in contact with the adult mattress.

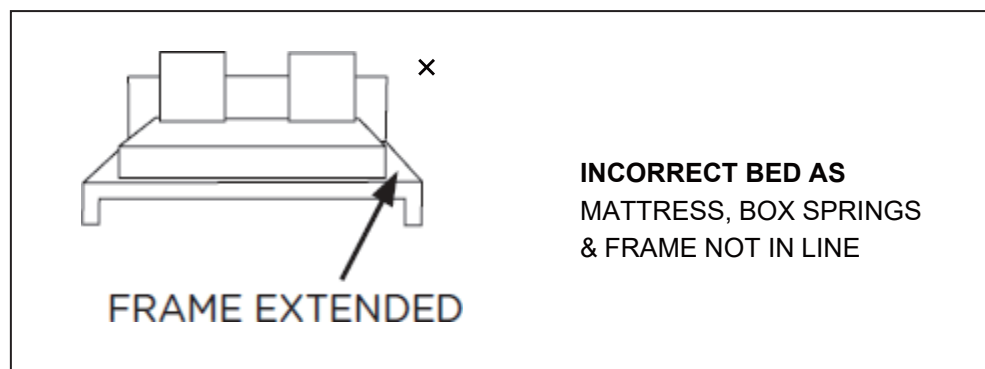
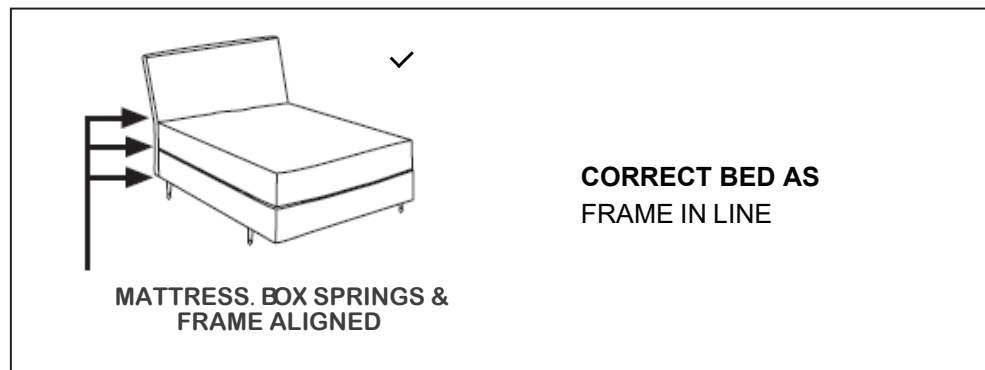
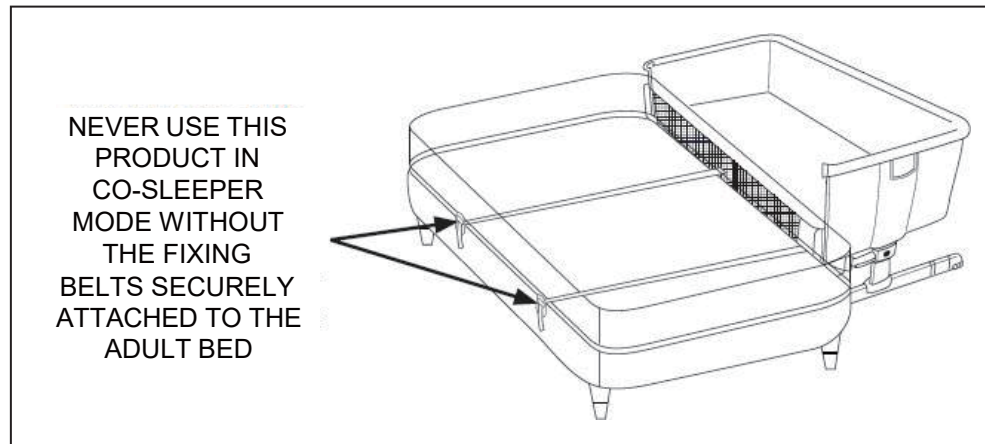

! WARNING!

THE ATTACHMENT SYSTEM MUST ALWAYS BE USED IN CO-SLEEPER MODE.

! WARNING!

- BEFORE EVERY USE, ALWAYS CHECK TO ENSURE THAT THERE IS NO SPACE BETWEEN THE ADULT MATTRESS AND THE SIDE OF THE CO-SLEEPER. IF THERE IS, PULL THE BELTS FIRMLY TO TIGHTEN UNTIL THERE IS NO SPACE.
- **USE OF PRODUCT IS ONLY PERMITTED WITH BEDS AND/OR MATTRESSES WITH STRAIGHT SIDES. DO NOT USE PRODUCT WITH A ROUND MATTRESS OR A WATER BED.**
- WHEN THE PRODUCT IS USED IN THE CO-SLEEPER MODE, IT MUST ALWAYS BE FITTED TO THE LONG SIDE OF THE BED. DO NOT FIX THE PRODUCT TO THE SHORT SIDE OF THE BED.

CARE & CLEANING

Remove the cover:

1. Remove the mattress and release the grip fasteners from the middle support frame on the underside of the bedside sleeper.

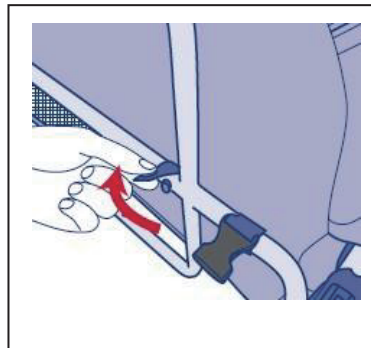
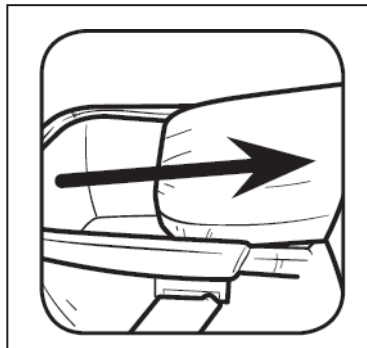

2. Unzip the zipper underneath the fabric lip on the upper frame. Pull out the removable outer fabric lining from the upper frame. Remove carefully so as not to damage the internal lining.

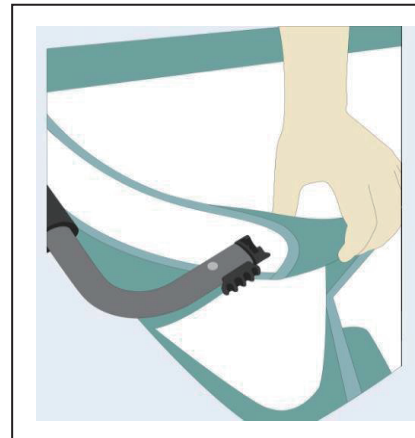
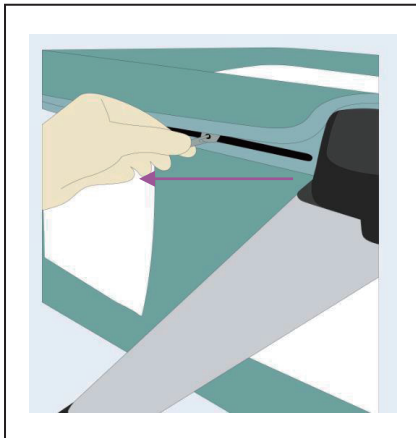

MAINTENANCE ADVICE

- The outer fabric lining is both removable and washable.
- Assembly and disassembly should be carried out by adults only. Regularly check the condition of the product for any possible damage. In case of damage, do not use it and keep it out of the reach of children.



Hand wash in cold water



Do not bleach



Do not tumble dry



Do not iron



Do not dry clean

After each wash, check the resistance of the fabric and the stitching.

WARNING : During the removal/or application of the lining, handle the fabric carefully in order to avoid accidental damage or tears.

WARNING : The removal and/or application of the lining should be carried out by an adult.