

# INSTRUCTION MANUAL

43220052

version  
**3**

[KMT088]

43220052\_MAN\_Powerbank 5000mAh-White

Artwork Proof Date: 27.12.2022

Number of artboards: 1

## PAPER:

80gsm

Bright white uncoated paper

## PRINT COLOURS:

BLACK

C:0 M:0  
Y:0 K:100

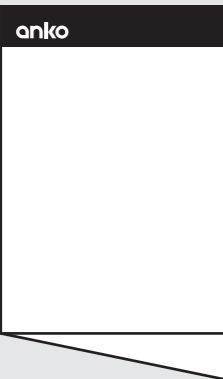

## PRINT FINISH:

Double sided

Folded in the centre

## CHANGE LOG CREST INTERNAL USE ONLY

v3.3: change white to blue light indicator on usage guideline

ARTWORK SHOULD NOT BE AMENDED WITHOUT PRIOR AGREEMENT FROM CREST.  
ALL ARTWORK MUST BE APPROVED BY CREST PRIOR TO MASS PRODUCTION.

IF THERE ARE QUERIES ABOUT THIS ARTWORK PLEASE CONTACT:  
EMAIL: [design@crest.com.au](mailto:design@crest.com.au)

THANK-YOU.

105

## 12 month warranty

Thank you for your purchase from Kmart.

Kmart Australia Ltd warrants your new product to be free from defects in materials and workmanship for the period stated above, from the date of purchase, provided that the product is used in accordance with the accompanying recommendations or instructions where provided. This warranty is in addition to your rights under the Australian Consumer Law.

Kmart will provide you with your choice of a refund, repair or exchange (where possible) for this product if it becomes defective within the warranty period. Kmart will bear the reasonable expense of claiming the warranty. This warranty will no longer apply where the defect is a result of alteration, accident, misuse, abuse or neglect.

Please retain your receipt as proof of purchase and contact our Customer Service Centre on **1800 124 125 (Australia)** or **0800 945 995 (New Zealand)** or alternatively, via Customer Help at [kmart.com.au](http://kmart.com.au) for any difficulties with your product. Warranty claims and claims for expense incurred in returning this product can be addressed to our Customer Service Centre at 690 Springvale Rd, Mulgrave VIC 3170.

Our goods come with guarantees that cannot be excluded under the Australian Consumer Law. You are entitled to a replacement or refund for a major failure and compensation for any other reasonably foreseeable loss or damage. You are also entitled to have the goods repaired or replaced if the goods fail to be of acceptable quality and the failure does not amount to a major failure.

For New Zealand customers, this warranty is in addition to statutory rights observed under New Zealand legislation.

**WARNING** do not dispose of unit in fire or water. > Never attempt to disassemble and reassemble. > Waste electrical products should not be disposed of with household waste, please recycle where facilities exist. > Check with your local authority for recycle advice. > Keep your device and all accessories out of reach of children and animals. > Small parts may cause choking or serious injury if swallowed. > Avoid exposing your device to very cold or very hot temperatures (below 0°C or above 45°C). > Extreme temperatures can cause deforming of the device and reduce the charging capacity and life of your device. > Do not allow your device to get wet-liquids can cause serious damage. > Do not handle your device with wet hands.

**anko**

## Portable Charger Dual USB 5,000mAh Operating instructions

includes:

- > powerbank
- > micro USB cable
- > manual



43-220-052

74.25

### Specification:

- > Battery: Li-ion polymer
- > Capacity: 5,000mAh / 18.5Wh
- > Micro USB & Type-C Input: DC5V==2A Max
- > Single USB Output up to 2A (for compatible device only)
- > Dual USB A Output: DC 5V/2A (combined output from 2 ports)
- > Dimensions: 98 x 64.5 x 16mm
- > Material: 22% Recycled ABS
- > Accessories: 30cm Micro USB charging cable in Recycled TPE material

### Product overview:

- ① USB-A2 Output port
- ② Type-C Input port
- ③ Micro Input port
- ④ USB-A1 Output port
- ⑤ LED indicator
- ⑥ Press button

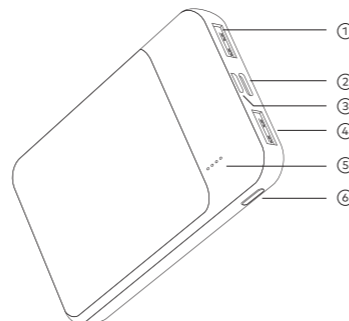

### Usage Guideline:

#### To charge the product

- > Plug in the supplied cable to an adaptor (not included) USB port, the Micro USB cable goes to your powerbank.
- > The 4 LED indicators will be shown when it is fully charged.

#### To charge your electronic device(s) using this product:

- > Turn on the power by pressing power ON button, blue LED light indicator will be lit.
- > Select from the 2 USB-A output ports to connect your device.
- > The powerbank will turn on automatically and charge.
- > The powerbank will turn off automatically after 30 seconds once you unplug your device. If you wish to turn the powerbank OFF, push the power button twice.

1. Before using the unit please read this manual carefully.
2. Ensure children and infants do not play with plastic bags or any packaging materials.
3. Children must not use this product without adult supervision.
4. Keep away from water, liquids, or wet areas.
5. Use a dry cloth to clean this product. Do not use chemicals on this product.
6. Do not expose the product to fire or high temperatures over 45°C.
7. Make sure the product has plenty of ventilation during charging.
8. Do not place the product in direct sunlight, heat or the under the windshield.
9. Do not drop, stand on, puncture, or apply excessive force to the product, as harsh impacts could damage the product. If unit is dropped or otherwise damaged, discontinue use immediately.
10. If crushed, punctured, disassembled, exposed to fire or high temperatures, batteries may catch fire or explode.
11. If the product swells or bulges, discontinue use immediately and dispose of the unit appropriately.
12. Do not insert foreign object into the product.
13. Do not try to repair or disassemble this product.
14. Do not charge the portable charger and charge your device simultaneously.
15. This product should be only operated from the type of power source indicated on the marking label.
16. To preserve battery lifespan, use and recharge at least once every 3 months.
17. For long-term storage (over 3 months), charge the device between 50 percent to 75 percent charge level.
18. When the unit is not in use, make sure it is correctly turned off and stored in a cool dry place.
19. When disposing of this product. Do so responsibly following local government requirements.

**WARNING:** READ AND FOLLOW ALL ABOVE INSTRUCTIONS CAREFULLY. DO NOT DROP OR APPLY EXCESSIVE FORCE TO THIS PRODUCT. DO NOT EXPOSE TO HIGH TEMPERATURES. IMPROPER USE OR HANDLING OF THIS PRODUCT MAY RESULT IN FIRE OR EXPLOSION CAUSING SERIOUS INJURY OR PROPERTY DAMAGE.