

Wooden Changetable Instruction Manual

0-12
months

11
KG

MAXIMUM
WEIGHT
LOAD OF
EACH LAYER

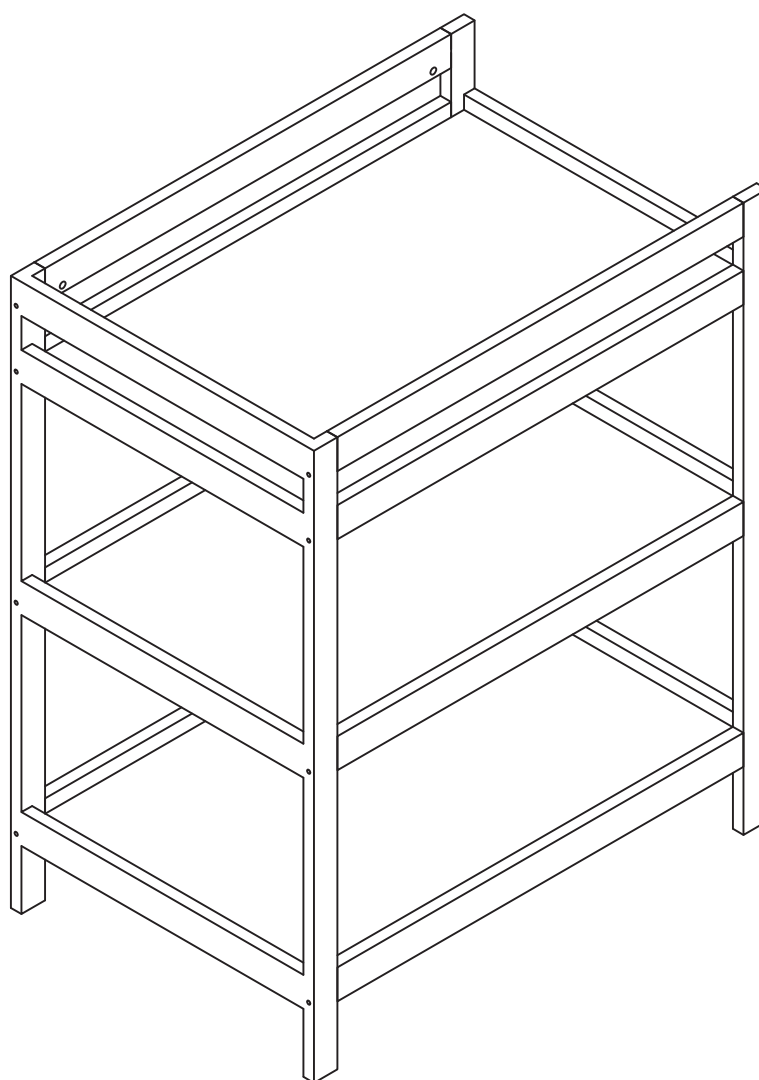

The photos and illustrations shown in this instruction manual are generic.
The manufacturer reserves the right to change any specification or feature without prior notice.

IMPORTANT. KEEP FOR FUTURE REFERENCE. READ CAREFULLY.

WARNING!

FALL HAZARD: Children have suffered serious injuries after falling from changing tables. Falls can happen quickly.

SUFFOCATION HAZARD: Babies have suffocated while sleeping on changing pads. Changing pads are not designed for safe sleeping.

- **STAY** in arm's reach of your child.
- Please read instructions carefully before assembly and use of this product and keep the packaging for future reference.
- **CONTOURED CHANGE MAT SIZE (NOT SUPPLIED):**
This change table has been manufactured for use with a change mat which measures 9.5cm(H) x 48cm(W) x 73.5cm(L).
Place change mat directly onto Change Tabletop shelf.
- This product is not intended to be used as a changing table without the change mat supplied by the manufacture.
Use of the product without this may result in death or serious injury to your child from falling.
Follow all instructions on attaching and using the change mat.
- Adult assembly required.
- Inspect the products before assembly and periodically during use. Never use this product if there are any loose or missing fasteners, joints, or broken parts.
- Regularly check that all fittings remain tight. Tighten if required.
- Do not use replacement parts that are not recommended or supplied by the manufacturer or distributor.
- Do not use once child reaches 12 months or 11kg.
- Do not allow older children to climb or play on the change table.
- Ensure the change table is placed at a reasonable distance away from open fires and other sources of strong heat, such as electric bar heater, gas fire, etc
- **NEVER** allow baby to sleep on changing pad.

Customer instructions:

- All assembly fittings are to be properly tightened.
- Inspect regularly and re-tighten as necessary.
- Wipe clean with a dry cloth. Do not use abrasive materials and solvents.
- Store in a dry place.
- For indoor and domestic use only.

Part list:

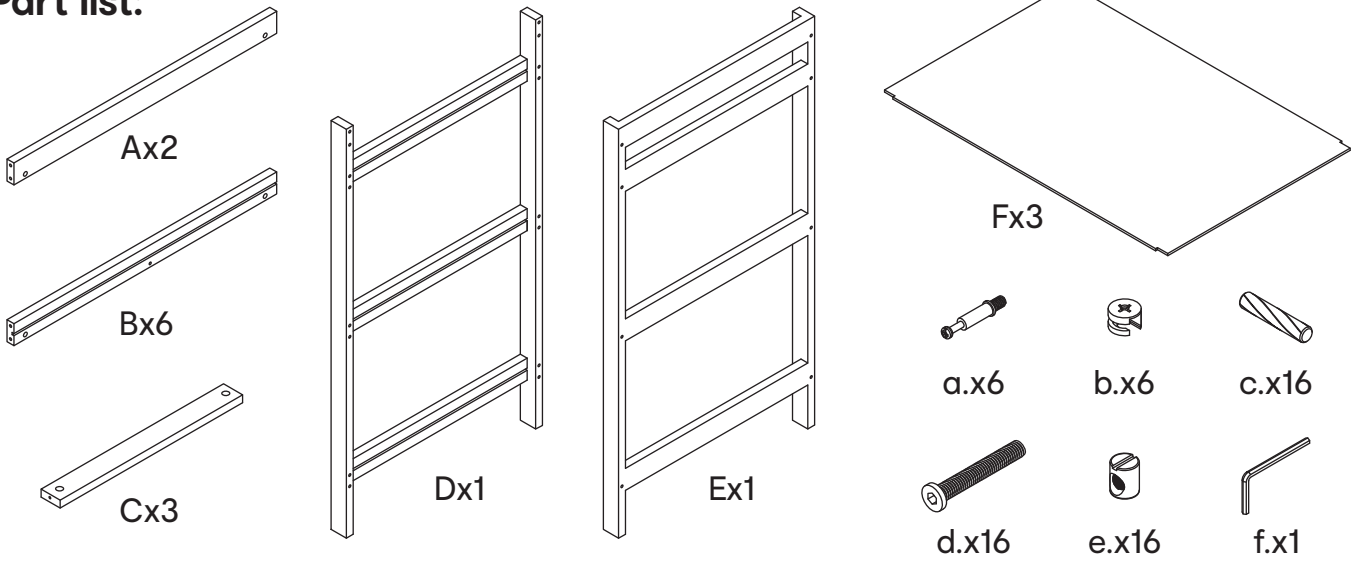

STEP 1

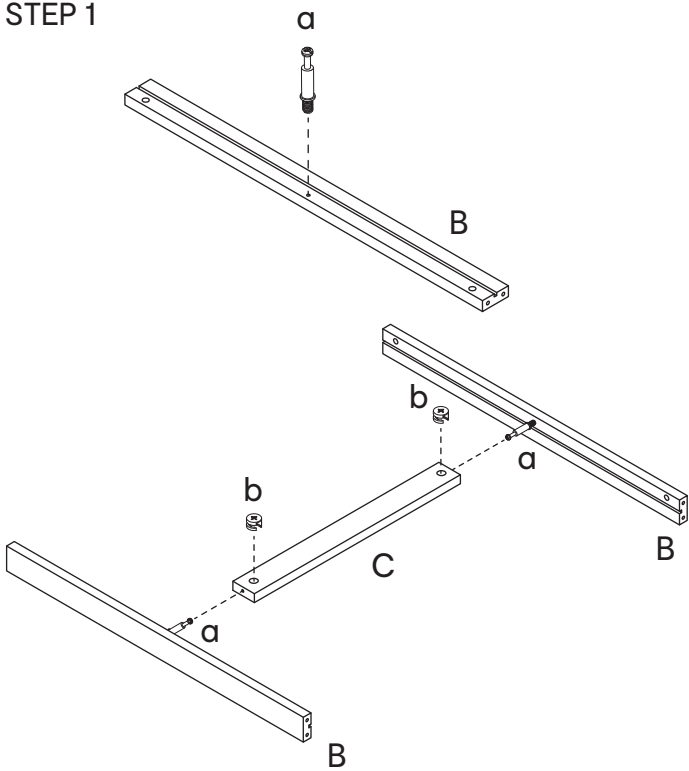

Repeat this step for another 2 H-shape structures.

STEP 2

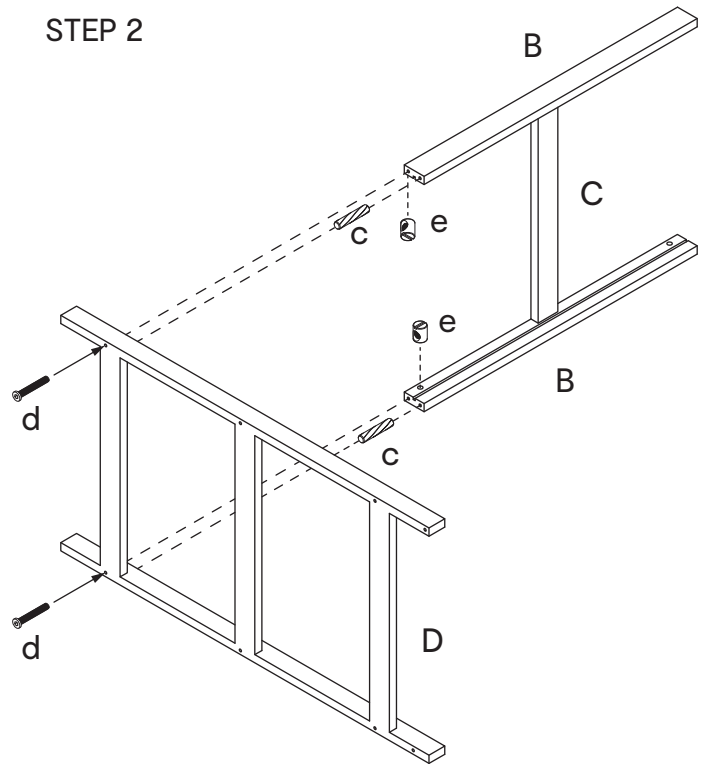

Repeat this step for another 2 levels.
Ensure they are secure by the allen key (f), but not tight.

STEP 3

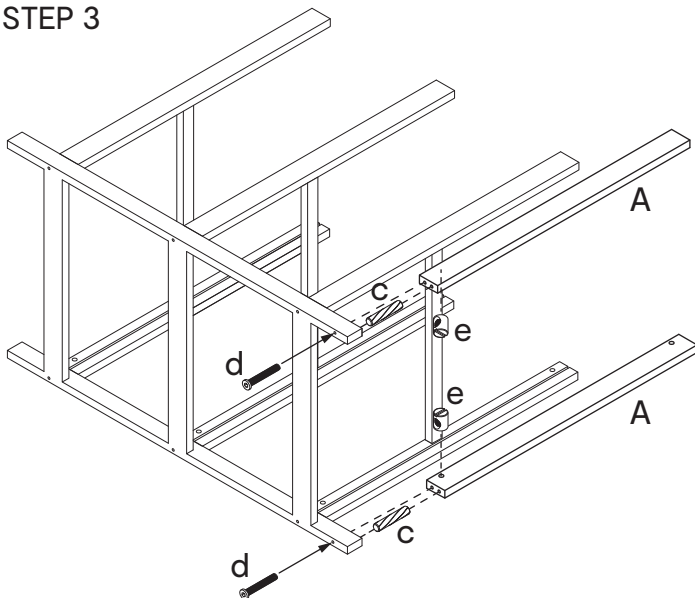

STEP 4

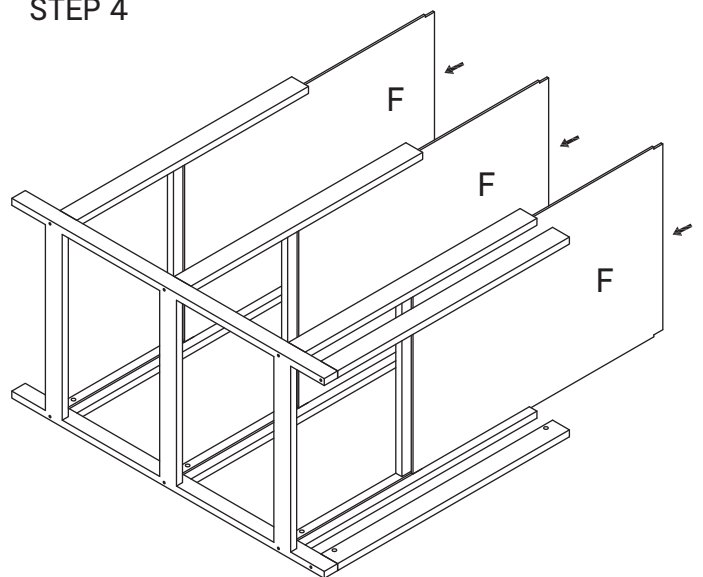

STEP 5

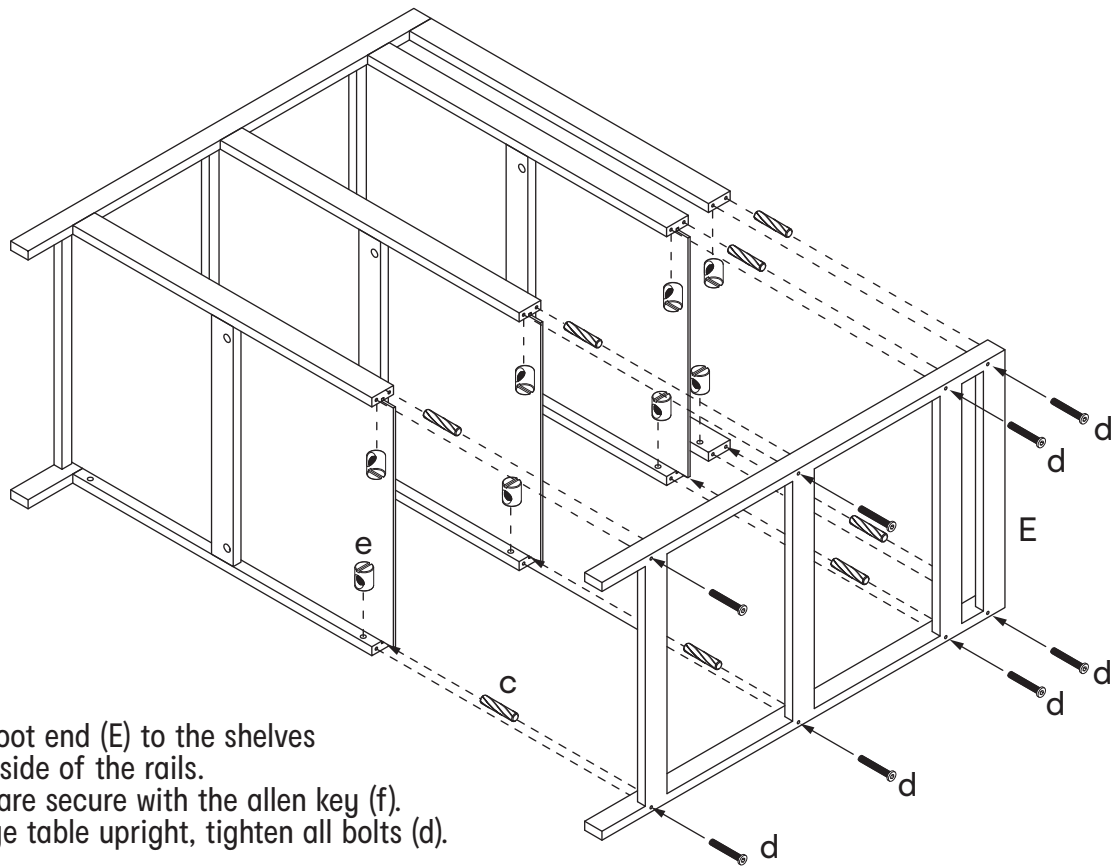

Attach the foot end (E) to the shelves and the top side of the rails.
Ensure that are secure with the allen key (f).
Stand change table upright, tighten all bolts (d).

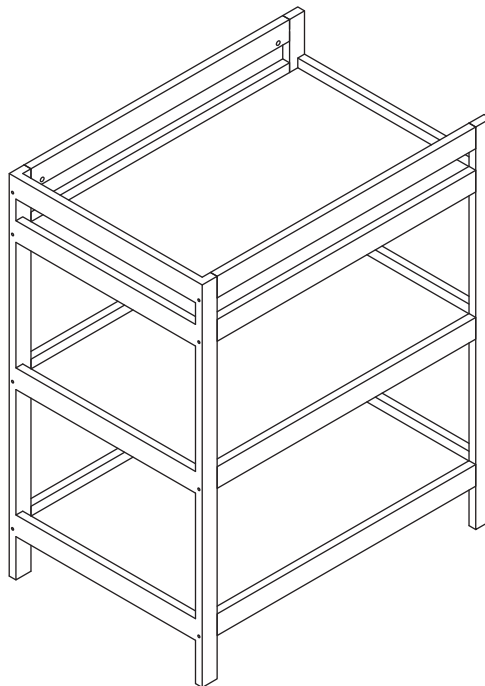

Keycode: 43-223-916

MADE IN CHINA

FOR AU / NZ: IMPORTED BY KMART FOR STORES IN AUSTRALIA AND NEW ZEALAND.

KMART AUSTRALIA - 690 SPRINGVALE ROAD, MULGRAVE, VIC 3170 AUSTRALIA.

KMART NEW ZEALAND - REGIONAL OFFICE C/O KMART PAPATOETOE STORE, HUNTERS PLAZA, GREAT SOUTH ROAD, PAPATOETOE, AUCKLAND, NEW ZEALAND.