

风琴折

128g双铜双面四色印刷

105*148.5mm

封面

封底

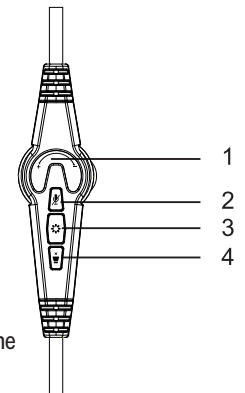
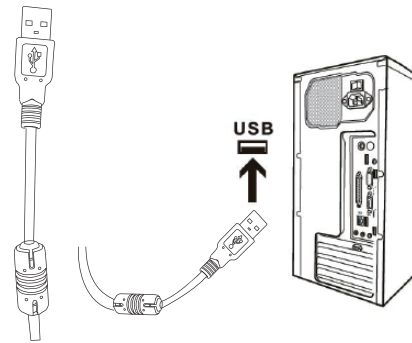
<p>anko</p> <h3>Gaming Headset Glow</h3> <p>Instruction manual</p>  <p>43-277-544</p>	<p>Please read all the information carefully before you use the product and keep the manual for future reference.</p> <p>Product specification Speaker Frame Diameter: 50mm Impedance: 20Ω±15% Sensitivity: 117±3dB Frequency Response: 20Hz-20kHz Mic size: φ4.0mm*1.5mm(H) Mic Sensitivity: -38dB±3dB Cable: PVC cable 2m±10% Dimension: 230*190*115mm Weight: 320g±5g</p> <p>Product features</p> <ul style="list-style-type: none">• Full panel earmuff & double head band RGB LED light• With separate controller, to control volume, mute, LED on/off• High precision 50mm driver brings vivid sound field• Soft high quality PU ear cushion suitable for long time wearing• Elegant RGB light defines your gaming style and makes the headset visible in a dark environment• Microphone to ensure perfect and clear voice communication <p>Controller function</p> <p>1. Volume+/-button Turn left/right of the volume key to increase/decrease the volume</p> <p>2. Microphone mute button Press this button to mute microphone volume</p> <p>3. RGB light switch button Press this button to turn on/off the RGB light</p> <p>4. Headset mute button Press this button to mute headset volume</p>  <p>1</p>	<p>Connect the headphone Plug the USB cable into USB ports of computer, the RGB light will turn on, after 3 seconds, the headset is ready to use. If you use a desktop computer, it is best to plug it into the USB ports on the back of the computer case instead of the USB ports on the front.</p>  <p>2</p>	<p>12 Month Warranty</p> <p>Thank you for your purchase from Kmart.</p> <p>Kmart Australia Ltd warrants your new product to be free from defects in materials and workmanship for the period stated above, from the date of purchase, provided that the product is used in accordance with accompanying recommendations or instructions where provided. This warranty is in addition to your rights under the Australian Consumer Law.</p> <p>Kmart will provide you with your choice of a refund, repair or exchange (where possible) for this product if it becomes defective within the warranty period. Kmart will bear the reasonable expense of claiming the warranty. This warranty will no longer apply where the defect is a result of alteration, accident, misuse, abuse or neglect.</p> <p>Please retain your receipt as proof of purchase and contact our Customer Service Centre on 1800 124 125 (Australia) or 0800 945 995 (New Zealand) or alternatively, via Customer Help at Kmart.com.au for any difficulties with your product. Warranty claims and claims for expense incurred in returning this product can be addressed to our Customer Service Centre at 690 Springvale Rd, Mulgrave Vic 3170.</p> <p>Our goods come with guarantees that cannot be excluded under the Australian Consumer Law. You are entitled to a replacement or refund for a major failure and compensation for any other reasonably foreseeable loss or damage. You are also entitled to have the goods repaired or replaced if the goods fail to be of acceptable quality and the failure does not amount to a major failure.</p> <p>For New Zealand customers, this warranty is in addition to statutory rights observed under New Zealand legislation.</p>
---	---	---	---