

anko

Dual USB-A Wall Adaptor

User Manual

43283316

Features

Support Max 18W fast charging

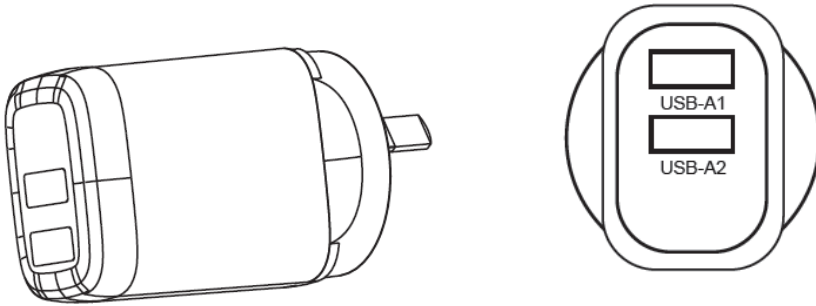

Safety Notes

1. Do not disassemble or throw into fire or water, to avoid damage.
2. Do not use adaptor in severely hot, humid or corrosive environments, to avoid circuit damage and occur leakage phenomenon.
3. To take care of the children, to ensure that they won't play the adaptor as a toy
4. In emergency cases, unplug the adaptor when smoke from the unit, changed shape, liquid or material leakage.
5. Do not use adaptor when it is damaged or broken parts.
6. This adaptor is intended for indoor use only.
7. For use with IT/AV products -Anko speaker, clock, projector only

Instruction:

1. Plug & Go: Just connect and start. Voltage and power will automatically configured by QC 3.0.
2. For efficient and optimize charging, the QC 3.0 function must be supported by your terminal device.
3. With the large quantity of QC-enabled terminal devices with different firmware versions, it can happen that the function is not fully supported.

Specification:

Input: 100-240V 50-60Hz

Output:

USB-A1: 5V / 3A, 9V / 2A, 12V / 1.5A

USB-A2: 5V / 2.1A

USB-A1 + USB-A = 18W (5V=2.4A, 9V=2A, 12V=1.5A) + 10.5W (5V=2.1A) = 28.5W

12 Month Warranty

Thank you for your purchase from Kmart.

Kmart Australia Ltd warrants your new product to be free from defects in materials and workmanship for the period stated above, from the date of purchase, provided that the product is used in accordance with accompanying recommendations or instructions where provided. This warranty is in addition to your rights under the Australian Consumer Law.

Kmart will provide you with your choice of a refund, repair or exchange (where possible) for this product if it becomes defective within the warranty period. Kmart will bear the reasonable expense of claiming the warranty. This warranty will no longer apply where the defect is a result of alteration, accident, misuse, abuse or neglect.

Please retain your receipt as proof of purchase and contact our Customer Service Centre on 1800 124 125 (Australia) or 0800 945 995 (New Zealand) or alternatively, via Customer Help at [Kmart.com.au](https://www.kmart.com.au) for any difficulties with your product. Warranty claims and claims for expense incurred in returning this product can be addressed to our Customer Service Centre at 690 Springvale Rd, Mulgrave Vic 3170.

Our goods come with guarantees that cannot be excluded under the Australian Consumer Law. You are entitled to a replacement or refund for a major failure and compensation for any other reasonably foreseeable loss or damage. You are also entitled to have the goods repaired or replaced if the goods fail to be of acceptable quality and the failure does not amount to a major failure.

For New Zealand customers, this warranty is in addition to statutory rights observed under New Zealand legislation.