

Artwork Proof Date: 07.06.2023

Number of artboards: 1

PAPER:
80gsm
Bright white uncoated paper

PRINT COLOURS:

BLACK
C:0 M:0
Y:0 K:100

PRINT FINISH:
Double sided
Folded in the centre
148.5 x 210 Folded Size



CHANGE LOG CREST INTERNAL USE ONLY

ARTWORK SHOULD NOT BE AMENDED WITHOUT PRIOR AGREEMENT FROM CREST.
ALL ARTWORK MUST BE APPROVED BY CREST PRIOR TO MASS PRODUCTION.
IF THERE ARE QUERIES ABOUT THIS ARTWORK PLEASE CONTACT:
EMAIL: design@crest.com.au
THANK-YOU.

crest © The Crest Company 2023. All rights reserved.

Recessed Surface Installation
Place spacers (M-A) between headplate and monitor. Loosely insert the upper two screws (W-B). Leave some space and hang the monitor on the head plate (see Figure 4).
Place spacers (M-A) between headplate and monitor. Insert the lower two screws (W-B) and fasten the upper two screws (see Figure 5).

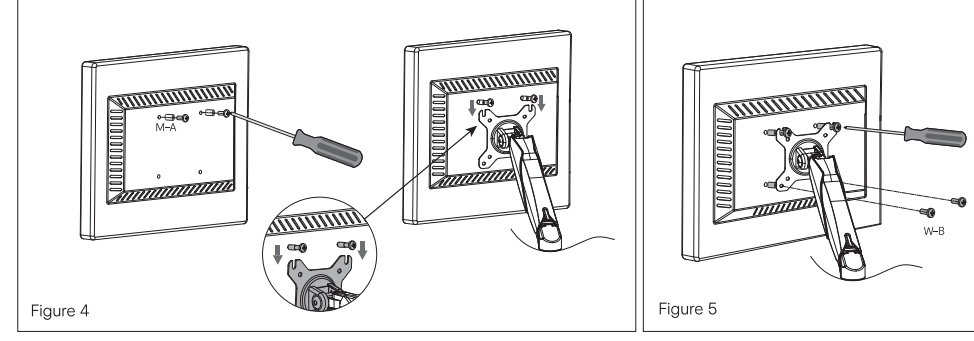

Adjusting the Monitor Mount
 > Push the arm downward to a horizontal position for easy adjustment (see Figure 6).
 > Using a hex wrench (W-E), adjust tension by turning the screw clockwise (tighten) or counter clockwise (loosen) depending on your monitors weight (see Figure 7).
 > Using a hex wrench (W-E), adjust screw to secure the monitor mount to the desired tilting position (see Figure 8).
 > Insert cables into cable holders (see Figure 9). Allow slack in the cables to cater for free motion of the mount.

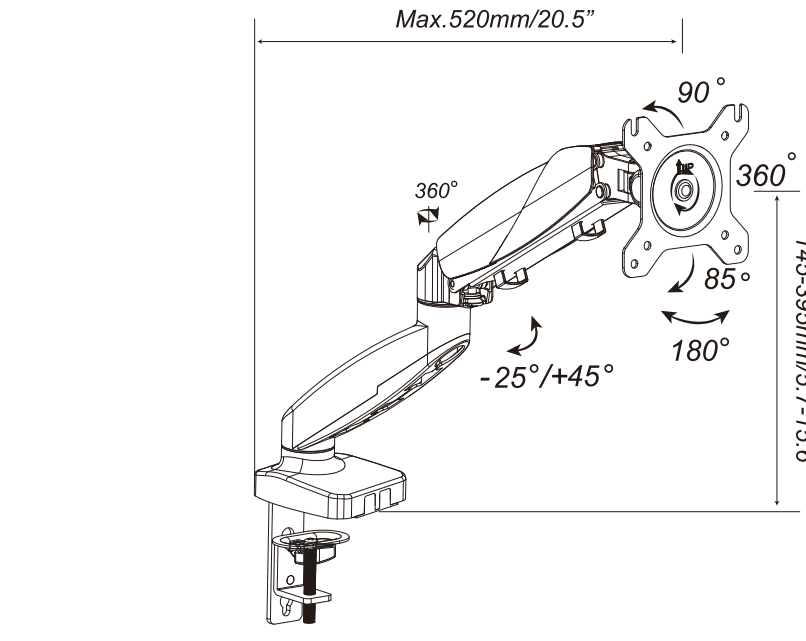
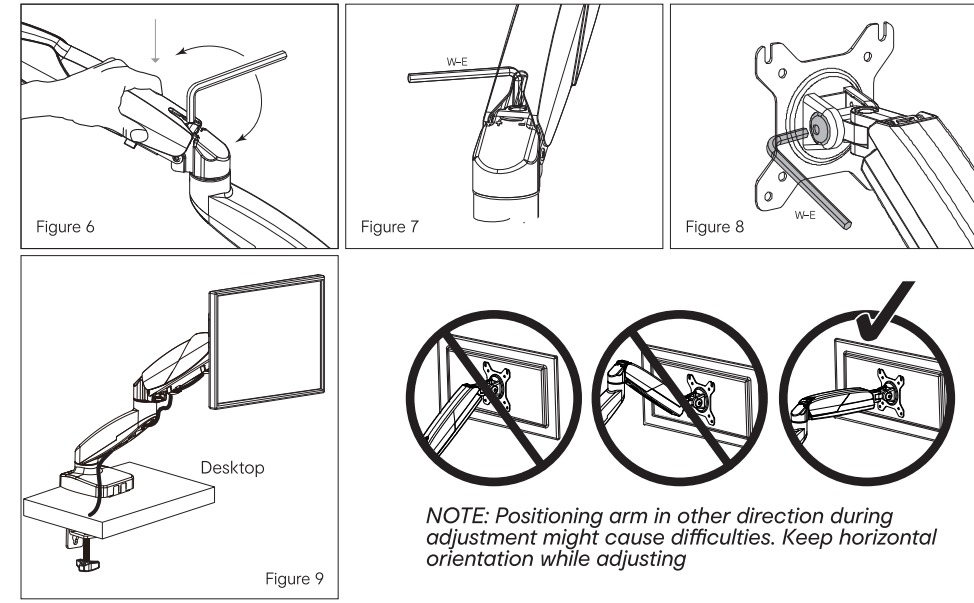

12 month warranty

Thank you for your purchase from Kmart.
Kmart Australia Ltd warrants your new product to be free from defects in materials and workmanship for the period stated above, from the date of purchase, provided that the product is used in accordance with the accompanying recommendations or instructions where provided. This warranty is in addition to your rights under the Australian Consumer Law.
Kmart will provide you with your choice of a refund, repair or exchange (where possible) for this product if it becomes defective within the warranty period. Kmart will bear the reasonable expense of claiming the warranty. This warranty will no longer apply where the defect is a result of alteration, accident, misuse, abuse or neglect.
Please retain your receipt as proof of purchase and contact our Customer Service Centre on **1800 124 125 (Australia)** or **0800 945 995 (New Zealand)** or alternatively, via Customer Help at **kmart.com.au** for any difficulties with your product. Warranty claims and claims for expense incurred in returning this product can be addressed to our Customer Service Centre at 690 Springvale Rd, Mulgrave Vic 3170.
Our goods come with guarantees that cannot be excluded under the Australian Consumer Law. You are entitled to a replacement or refund for a major failure and compensation for any other reasonably foreseeable loss or damage. You are also entitled to have the goods repaired or replaced if the goods fail to be of acceptable quality and the failure does not amount to a major failure.
For New Zealand customers, this warranty is in addition to statutory rights observed under New Zealand legislation.



Single Arm Monitor Mount
Operating instructions

- > single arm monitor mount
- > assembly pack
- > user manual



43-305-414

Warning Statements
 > Prior to the installation of this product, the installation instruction must be read and completely understood. Failure to do so may result in personal injury, property damage or voiding of factory warranty.
 > Do not install on a structure that is prone to vibration, movement or chance of impact. Reinforce the structure as required before installation.
 > The desk clamp can support a maximum thickness of 10cm. Confirm the desk edge before installation.
 > Do not exceed the weight limitation of the mount. Exceeding the limitation may affect the functionality of the product, or result in serious personal injury and/or property damage.
 > Never operate the mount if parts are missing or damaged. Contact your local service center for warranty service.

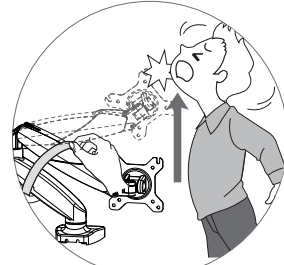

Warning Symbol
Arm spring back may occur upon release of cable tie. Please hold the folded arm tightly and open it slowly when taking it from the packaging and removing the tie on it. Proper handling must be taken into consideration. Failing to do so may lead to physical injuries.

Hardware Kit Content

ITEM	DESCRIPTION	QTY
W-A	M4 x 12 Bolt	4
W-B	M4 x 30 Bolt	4
W-C	M6 x 12 Hex Screw	3
W-D	4mm Hex	1
W-E	5mm Hex	1
M-A	12 x 5.8 x 16 Spacer	4

Grommet Installation

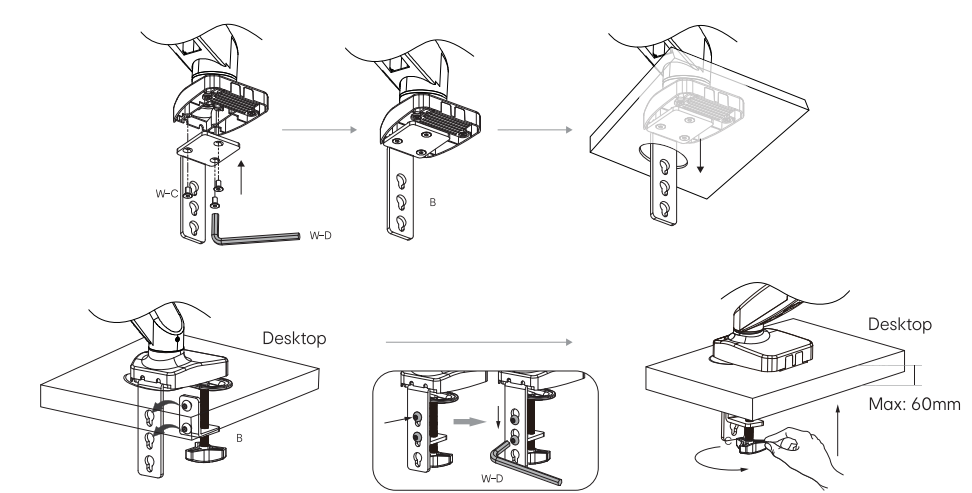

NOTE: If your desk has an existing grommet hole, please install directly. If there is no existing grommet hole, make a mark on your mounting surface, and use a drill to drill a hole (40-60mm) in the mounting surface.

Desk Clamp Installation

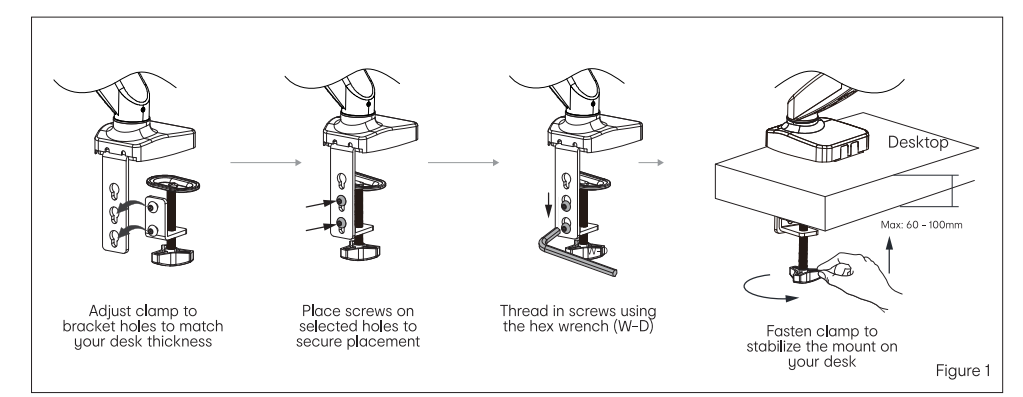
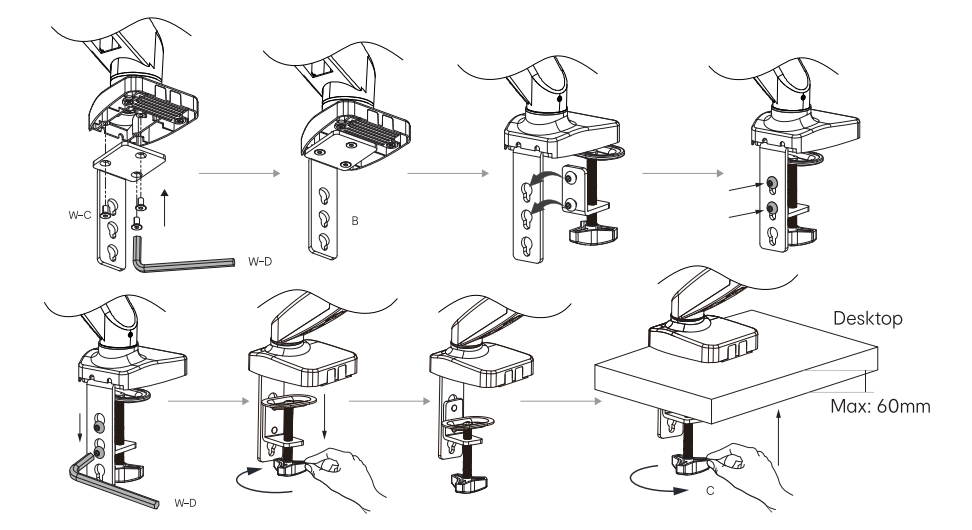

NOTE: Adjust the desk clamp clamping range using the adjustment hole. Position the clamp to the required thickness of the desktop (see Figure 1).

Monitor Mount Installation

Flush Surface Installation
Loosely insert the upper two screws (W-A). Leave some space and hang the monitor on the head plate (see Figure 2).
Insert the lower two screws (W-A) and fasten the upper two screws (see Figure 3).

