

100mm      100mm      100mm      100mm      100mm

**K: 43338863 | T: 68765163**  
**Botanical Aroma Diffuser**  
**Instruction Manual**

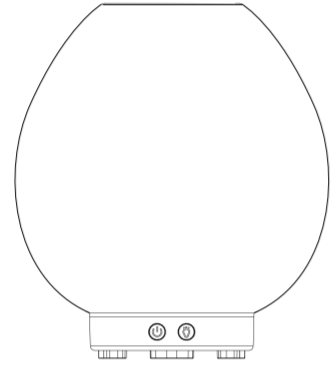

Create an aromatic, soothing atmosphere in your home. Use ultrasonic vibration on transform water into mist. Essential oil can be added to create fragrance.

**IMPORTANT!**

Care should be taken with the use of diffusers around animals. Both the choice of essential oils and where animals are should be taken into consideration when in use. This appliance is not intended for use by persons (including children) with reduced physical, sensory or mental capabilities, or lack of experience and knowledge, unless they have been given supervision or instruction concerning use of the appliance by a person responsible for their safety. Children should be supervised to ensure that they do not play with the appliance. The appliance is only to be used with the power supply unit provided with the appliance. For details regarding filling, please refer to section "OPERATION METHOD" of the user manual. For details regarding cleaning, please refer to section "MAINTAINENCE" of the user manual. Unplug the appliance during filling and cleaning.

**Includes**

Main unit  
AC Adapter: Input 100~240V. a.c Output 24V.d.c

**Names Of Parts**

01. Waterproof cover
02. Water tank
03. LED lights(built-in)
04. Base
05. The outlet
06. Fog shock tablets
07. Light button
08. mist button
09. Inlet
10. DC power jack
11. Power Adapter
12. Top

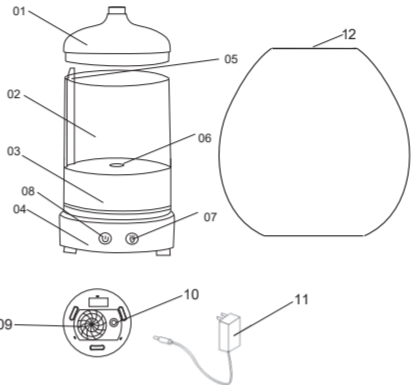

**Mist (Power) and Light Buttons**

Mist (Power) button (left side)

- 1st press: power on with continuous mist mode
- 2nd press: switch to 30s timer
- 3rd press: switch to 1h timer
- 4th press: switch to 2h timer
- 5th press: turn off the unit

**Light button (right side)**

- 1st press: turn the light on and the color will automatically change from red-yellow-green-teal-blue-purple-white and cycling
- 2nd press: fixed current light
- 3rd press -16th press: change and fixed the color (from light red-red-light yellow-yellow-light green-green- light teal-teal-light blue-blue-light purple-purple-light white-white)
- 17th press: turn off the light (you also can long press to turn off the light)

**Water tank**

The machine has a water shortage detector which will automatically power off the unit if water is too low. Please ensure there is always adequate water to avoid damaging the diffuser.

**Auto shut off function**

When water is running out, the unit will switch off. The machine will automatically power off if abnormal overheating is detected.

**Operation**

Open the top cover. Add water up to max water level into the water tank then add 2 to 3 drops of essential oil, depending on your preference of more or less fragrance.

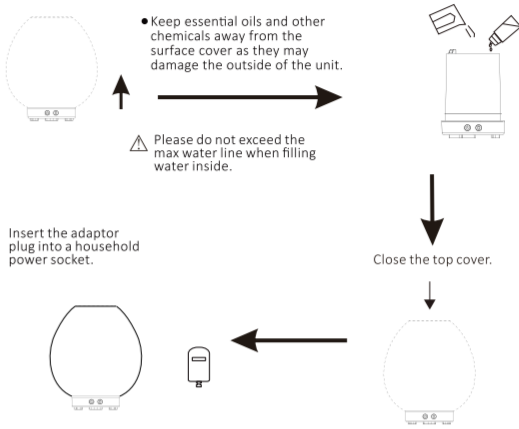

**Cleaning and maintenance**

The machine should be cleaned after using for 3-5 days continuously, to keep it working normal and extend the lifetime.

1. Unplug the machine before cleaning.
2. Please clean water tank with a brush and white vinegar or the dilution of detergent and warm water. Others part of the cover can be cleaned with a soft cloth.
3. Please do not put the whole machine or base into water. Temperature of water cannot be over 40 degrees to clean.

正面

100mm      100mm      100mm      100mm      100mm

4. When the machine is not used for a long period of time, please pour out the water in the tank and wipe off the drops, then place it in a shady and cool place to avoid direct sunlight.

5. Please clean the tank regularly.

**Caution:**

Please do not pour out water through the air outlet as this can damage the inside of the machine.

**How to pour out the water**

To avoid water flowing into the air outlet, Please pour out the water correctly.

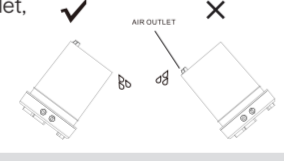

**Attention**

To prevent less or no steam from the diffuser, do not add water above the max level mark.

To prevent melting damage, do not add more than 5 drops of essential oil into the container.

- Do not use as a medical respirator
- Do not use the product when there is an abnormal noise or the diffuser is overheating abnormally.
- Do not cover or block the most outlet or air inlet
- Do not take off the cover during operation of the diffuser
- Do not place near an electric device such as computer, TV or audio equipment.

- Do not use hot water or mineral water. Always use tap water or distilled water.

- Keep out reach of children and pet.

**Warning**

1. Important safety instructions: The following safety precautions should always be followed, to reduce the risk of electric shock, personal injury or fire. It is important to read all of these instructions carefully before using the product, and to save them for future reference or new users.
2. Unplug the appliance during filling and cleaning.
3. This appliance is not intended for use by persons (including children) with reduced physical, sensory or mental capabilities, or lack of experience and knowledge, unless they have been given supervision or instruction concerning use of the appliance by a person responsible for their safety.
4. Children should be supervised to ensure that they do not play with the appliance.
5. Care should be taken when using the appliance due to the emission of hot water vapour.
6. The appliance is only to be used with the recommended vaporizing medium. The use of other substance may give rise to a toxic or create a fire risk.
7. Use supplied AC adaptor only.

**Troubleshooting**

If you start the diffuser but it doesn't work, please check the following diagnosis.

Problems	Possible Reasons	Solution
No electricity, no working.	Power not connected	Connect the power, press the button.
	Power wire broken or adaptor burnt out.	Please contact local retailer.
Unable to spary mist or spray is bad	Is the water leave low?	Please fill with more water.
	Is there too much water inside the tank?	If the water volume exceeds 180ml (max water line), the mist volume will be minimal.
	Is the ceramic disc dirty?	Please clean the water tank.
	Is the top cover correctly placed?	Please place top cover in the correct sport.
Main body is leaking water.	Is the bottom air inlet dirty?	Please clear away the dust in the bottom air inlet.
	Is the top cover correctly covered?	If the top cover is not correctly covered, the water will splash out and fall onto the machine body or table.
	Condensation water on the body may be caused by low-temperature or a humid environment.	please avoid low-temperature and humid environments.

**12 Month Warranty**

Thank you for your purchase. Your new product is warranted to be free from defects in materials and workmanship for the period stated above, from the date of purchase, provided that the product is used in accordance with accompanying recommendations or instructions where provided. This warranty is in addition to your rights under the Australian Consumer Law. For New Zealand customers, this warranty is in addition to statutory rights observed under New Zealand legislation.

We will provide you with your choice of a refund, repair (where possible) or exchange (availability dependent) for this product if it becomes defective within the warranty period. The business will bear the reasonable expense of claiming the warranty. This warranty will no longer apply where the defect is a result of alteration, accident, misuse, abuse or neglect.

Please retain your receipt as proof of purchase and contact our Customer Service Centre as listed below, for the entity you purchased this product from, for any difficulties with your product. Warranty claims and claims for expense incurred in returning this product can be addressed to the respective Customer Service Centre.

Our goods come with guarantees that cannot be excluded under the Australian Consumer Law. You are entitled to a replacement or refund for a major failure and compensation for any other reasonably foreseeable loss or damage. You are also entitled to have the goods repaired or replaced if the goods fail to be of acceptable quality and the failure does not amount to a major failure.

Contact for Kmart purchases	Contact for Kmart purchases
Kmart Australia Ltd. C/- Customer Service Centre 690 Springvale Road, Mulgrave Vic 3170 Customer Service: 1800 124 125 (Australia) or 0800 945 995 (New Zealand) or via Customer Help at kmart.com.au	Target Australia Pty Ltd C/- Customer Service Centre 2 Kendall Street, Williams Landing, Vic. 3027 Customer Service: 1300 753 567 or via Customer Help at target.com.au/help/contact-us

反面