

READ AND SAVE IMPORTANT SAFETY INSTRUCTIONS

White Ceramic Aroma Diffuser

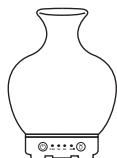

Model B-0353-1
K: 43339723
T: 68761745

IMPORTANT!

Care should be taken with the use of diffusers around animals. Both the choice of essential oils and where animals are should be taken into consideration when in use.

WARNING- TO REDUCE THE RISK OF BURNS, FIRE, ELECTRIC SHOCK, OR INJURY TO PERSONS:

For filling, please refer to section "GETTING STARTED OPERATING INSTRUCTIONS"
For cleaning and descaling, please refer to section "CARE AND MAINTENANCE"

- DO NOT** block the air inlet at the bottom of the diffuser.
- DO NOT** use the diffuser on flammable surfaces or near flammable materials, heat sources or open flames.
- DO NOT** use if the adaptor or diffuser is damaged. If the diffuser malfunctions, is damaged or is immersed in water, stop using the diffuser.
- Only use with the adaptor provided.
- Indoor dry location use only.
- DO NOT** touch the ultrasonic disc with a finger or scrape it with metal tools to avoid damage to the disc.
- This appliance is not intended for use by persons (including children) with reduced physical, sensory or mental capabilities, or lack of experience and knowledge, unless they have been given supervision or instruction concerning use of the appliance by a person responsible for their safety.

- Children should be supervised to ensure that they do not play with the appliance.
- DO NOT** immerse the diffuser in water or any other liquid.
- Always use fragrance with water. Do not use fragrance on its own.
- DO NOT** leave the diffuser on or unattended overnight.
- Only use with essential oil or water-based fragrance. Acidic oil can damage the diffuser. Check the instructions of the oil or fragrance.
- The appliance is only to be used with the recommended vaporizing medium. The use of other substances may give rise to a toxic or create a fire risk.
- Use provided AC adaptor only.
- Unplug the appliance during filling and cleaning.

- Ultrasonic disc
- Power button
- 0.5-hour light
- 1-hour light
- 2-hour light
- 3-hour & steady on light
- Light button
- Vent
- Reservoir lid
- Reservoir

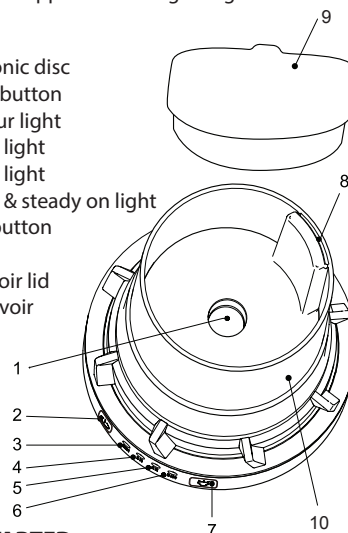

GETTING STARTED OPERATING INSTRUCTIONS

- Remove the ceramic cover and the reservoir lid.
- Insert the DC jack of the adaptor into the DC socket at the bottom of the base.
- Fill the reservoir with water. For maximum run time, fill to 'Max' line - 100ml. Always use room temperature water.

CAUTION

Do not overfill the reservoir.
Do not use water over 45°C.
Do not fill water through the vent.

- Add 2 to 3 drops of essential oil to a full tank of water. For a stronger fragrance add more drops of oil, but do not exceed 4 drops.
- DO NOT** add more than 2 drops of essential oil to 20ml of water. Adding too much oil will damage the diffuser.
- Replace the reservoir lid and the cover securely.
- Plug the AC adaptor into a wall outlet.

DIFFUSER SETTINGS

- Place the diffuser on a stable and level surface.
- Press Power button (2) to turn the diffuser on.
 - Press once for 30 mins
 - Press 2 times for 60 mins
 - Press 3 times for 2 hours
 - Press 4 times for 3 hours & steady on
- Press and hold Power button to turn off the diffuser.

AUTO-OFF FUNCTION

The diffuser will turn off automatically when the reservoir is out of water or the timer is up.

LIGHT SETTINGS

- Press Light button (7) to control the light.
- There are 7 light colours with various brightness. Press the light button repeatedly to go through different settings.
- You can choose and set the light colour. The colour sequence of the light button control is : Automatic colour changing-current colour-dim red-bright red-dim purple-bright purple-dim yellow-bright yellow-dim blue-bright blue-dim sky blue-bright sky blue-dim green-bright green-dim cream-bright cream.

MOVING AND STORAGE INSTRUCTIONS

- DO NOT** move the diffuser while in use. Spillage may cause damage to the diffuser and other parts.
- Always hold both the base and the cover when moving the diffuser.
- Empty the reservoir and clean the diffuser before storing.

CARE AND MAINTENANCE

- Always turn OFF and unplug the diffuser for care and maintenance.
- Clean the reservoir before using a different essential oil.

3. Empty the reservoir using the vent.
4. Clean the reservoir with a soft cloth.
5. Clean scale deposits on the ultrasonic disc with clean water.
6. **DO NOT** use metal or hard abrasive to scrape the ultrasonic disc.
7. Clean the ultrasonic disc regularly to avoid scale building up.
8. If the ultrasonic disc becomes excessively scaled, clean it repeatedly to descale.
9. Dry the diffuser completely before using it again.
10. **DO NOT** use vinegar or other corrosive cleaning agents.
11. Wipe off the fan inlet regularly at the bottom with a dry, soft cloth.

12 Month Warranty

Thank you for your purchase.

Your new product is warrantied to be free from defects in materials and workmanship for the period stated above, from the date of purchase, provided that the product is used in accordance with accompanying recommendations or instructions where provided. This warranty is in addition to your rights under the Australian Consumer Law.

For New Zealand customers, this warranty is in addition to statutory rights observed under New Zealand legislation.

We will provide you with your choice of a refund, repair (where possible) or exchange (availability dependent) for this product if it becomes defective within the warranty period. The business will bear the reasonable expense of claiming the warranty.

This warranty will no longer apply where the defect is a result of alteration, accident, misuse, abuse or neglect.

Please retain your receipt as proof of purchase and contact our Customer Service Centre as listed below, for the entity you purchased this product from, for any difficulties with your product. Warranty claims and claims for expense incurred

in returning this product can be addressed to the respective Customer Service Centre.

Our goods come with guarantees that cannot be excluded under the Australian Consumer Law. You are entitled to a replacement or refund for a major failure and compensation for any other reasonably foreseeable loss or damage.

You are also entitled to have the goods repaired or replaced if the goods fail to be of acceptable quality and the failure does not amount to a major failure.

Contact for Kmart purchases

Kmart Australia Ltd.
C/- Customer Service Centre 690 Springvale Road, Mulgrave Vic 3170
Customer Service: 1800 124 125 (Australia) or 0800 945 995 (New Zealand) or via Customer Help at kmart.com.au

Contact for Target purchases

Target Australia Pty Ltd
C/- Customer Service Centre
2 Kendall Street, Williams Landing, Vic, 3027
Customer Service: 1300 753 567 or via Customer Help at target.com.au/help/contact-us

Troubleshooting

Problem	Possible Reasons	Solution
Unit does not work	Power cable not connected	Re-connect power with cord cable and press the button
	Power device failure	Change power device
Unable to Spray mist	Water reservoir might be dirty	Clean the water reservoir
	Too much water inside the reservoir	Make sure water inside the reservoir is not over max water level
	Cover is not closed properly	Make sure the cover is tightened
	Is the bottom air inlet dirty?	Clear away the dust in the bottom air inlet
	Water level very low	Fill with more water

Caution:

DO NOT shake or tilt the product when there is water in the reservoir or else the product will not work properly