

anko

Milkshake Maker HSM-706S User Manual

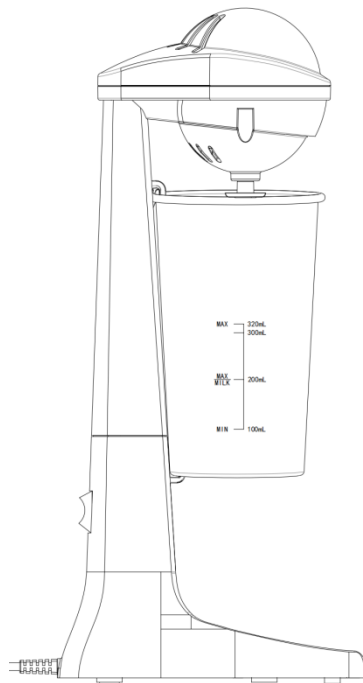

PLEASE READ AND SAVE THESE
INSTRUCTIONS FOR FUTURE REFERENCE

IMPORTANT SAFEGUARDS

When using any electrical product, always follow these basic safety precautions:



READ ALL INSTRUCTIONS BEFORE USE

WARNING:

1. To protect against electrical shock, do not submerge the appliance or allow the power cord to come in contact with water or any other liquid.
2. This appliance is not intended for use by persons (including children) with reduced physical, sensory or mental capabilities, or lack of experience and knowledge, unless they have been given supervision or instructions concerning the use of the appliance by a person responsible for their safety.
3. Children should be supervised to ensure that they do not play with the appliance.
4. Never let the appliance operate unattended.
5. Remove the power cord from the electrical outlet when not in use, before assembling or disassembling parts and before cleaning. To unplug, grasp the plug and pull from the mains power outlet socket. Never pull from the power cord.
6. DO NOT abuse the power cord. Never carry the appliance by the power cord or yank it to disconnect from electrical outlet; instead grasp on the plug and pull to disconnect.
7. DO NOT operate the appliance with a damaged cord or plug, or after the appliance malfunctions, has been dropped or damaged in any manner.
8. If the power cord is damaged, it must be replaced by a qualified electrical person in order to avoid a hazard or the appliance must be disposed of.
9. DO NOT let the power cord hang over the edge of table or counter or touch hot surfaces such as the stove.
10. Always use the appliance on a dry, level surface. Sink, drain boards or uneven surfaces must be avoided.
11. Keep hands, hair, clothing, as well as utensils out of cup while processing to reduce the risk of severe injury to persons or damage to the appliance.
12. Avoid contact with moving parts.
13. DO NOT operate this appliance on or near any hot surface (such as gas or electric burner or in a heated oven).
14. The use of attachments or accessories not supplied with the product may cause fire, electric shock or personal injury.
15. DO NOT remove the cup from the appliance while the appliance is running.
16. DO NOT try to defeat the safety lock mechanism; make sure that the cup is properly loaded before operating the appliance.
17. DO NOT overfill.
18. DO NOT operate the appliance when the cup is empty. DO NOT remove the cup before the stirrer has come to a complete stop.
19. THIS PRODUCT IS INTENDED FOR HOUSEHOLD USE ONLY. Do not use this appliance for anything other than its intended use. Do not use outdoors.
20. Check the voltage indicated on the appliance corresponds to the local mains voltage before you connect the appliance.
21. Never immerse the appliance in water or any other liquid, do not rinse it under the tap. Use only a moist cloth to clean the unit.

22. Unplug the appliance immediately after use.
23. Switch off the appliance and disconnect from mains power before changing accessories or approaching parts that move in use.
24. Keep the appliance out of the reach of children.
25. Fingers and foreign objects should not be placed inside the cup whilst in operation.
26. Always unplug the appliance before you start cleaning the appliance.
27. Do not attempt to repair or disassemble the appliance. There are no user-serviceable parts inside the appliance.
28. For cleaning, please refer to CLEANING AND STORAGE section.
- 29. DO NOT pour hot liquid into the milkshake maker as it can be ejected out of the appliance due to a sudden steaming.**
30. Always disconnect the appliance from the mains power before approaching or changing parts.
31. The appliance is intended to be used in household and similar applications such as:
 - staff kitchen areas in shops, office and other working environments,
 - farmhouses,
 - by clients in hotels, motels and other residential type environments,
 - bed and breakfast type environments.

WARNING! Misuse of the appliance may cause injury!

Extension cords are not recommended for use with this product.

IMPORTANT!

To prevent damage to the electric motor, the maximum operating time is 1 minute. Allow it to rest for at least 2 minutes before using it again. After 5 cycles of operation, allow the Milkshake Maker to cool down for approx. 30 minutes before using it again.

**SAVE THESE INSTRUCTIONS
FOR HOUSEHOLD USE ONLY**

KNOW YOUR MILKSHAKE MAKER

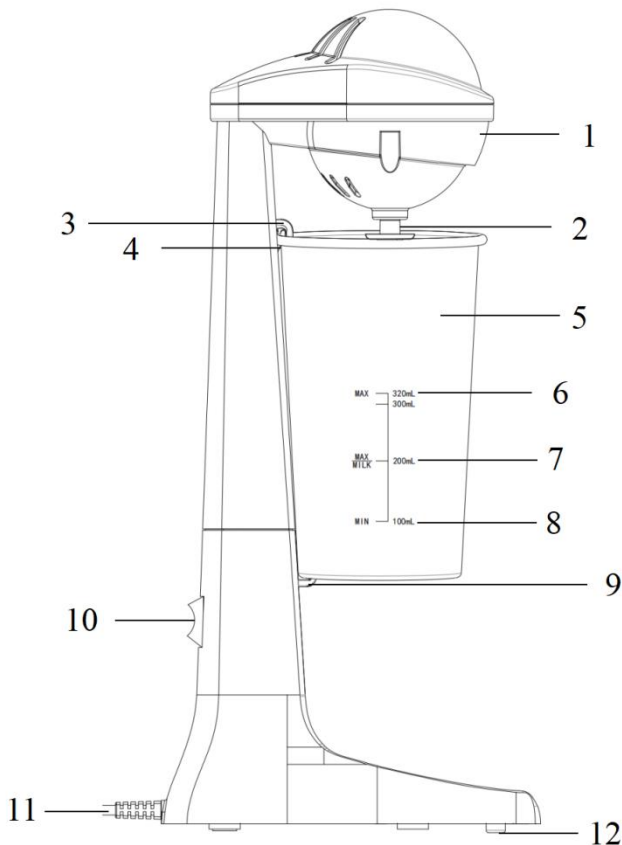

1. Motor head
2. Stirrer
3. Cup clamp
4. Safety lock
5. Cup
6. MAX. mixture volume (320mL)
7. MAX. milk volume (200mL)
8. MIN. Mixture volume (100mL)
9. Cup holder
10. Speed I/OFF/Speed II switch
11. Power plug and cord
12. Rubber feet

IMPORTANT!

Please make sure that your appliance is received with all the components shown above. Check everything carefully before use.

BEFORE FIRST USE

Note: When using the appliance for the first time, carefully remove all packaging.

1. Before using the product for the first time, wash the cup in warm, soapy water, then rinse and dry thoroughly.
2. Clean the appliance with a damp cloth or sponge. Wipe dry with a soft dry cloth.

CAUTION: Never immerse the appliance in water or other liquids. Never use abrasive cleaners on any part of the product. Do not place any parts into a dishwasher.

Place the appliance on a flat, stable and non-slip surface, the appliance is now ready for use.

USE YOUR MILKSHAKE MAKER

1. Make sure the switch at “O” position.
2. Pour milk into the cup. The amount of the milk should be no more than 200ml.

Note: Do not fill milk more than 200mL ("MAX/MILK" mark) and all ingredients for mixing should not exceed 320mL ("MAX" mark) to prevent the mixture from splashing out during mixing.

3. Add Milkshake powder and sugar (or any other ingredients that you prefer) into the cup.

Note: If adding powder that foams easily, try with a small amount first.

4. Load the cup on the appliance with cup holder and clamp.
5. Connect the power cord plug into a mains power outlet.
6. Press the switch to speed “I” or “II” as you need (max. operating time at a time is 1 minute).
7. Press the switch to “O”. Let the Milkshake Maker cool down for approximately 2 minutes before continuing with stirring.

WARNING! Do not operate the motor continuously for more than 1 minute at a time. Allow the motor to rest for 2 minutes before continuing.

8. Make sure the switch at “O” after use.
9. Disconnect the plug from mains power after use.

TIPS:

Do not overfill cup beyond markings.

For more volume, use low fat milk as full cream milk does not froth as much as low fat milk.

Ice cream and fruit added will increase the volume of the milkshake.

Cool down the ingredients before use as this will achieve maximum volume.

CLEANING AND STORAGE

CAUTION: Never immerse the appliance in water or other liquids. Never use abrasive cleaners on any part of the product. Do not place any parts into a dishwasher.

- Clean the milkshake maker after each use.
- Remove the power cord from the power outlet socket and ensure the appliance is thoroughly cooled before cleaning.
- Clean the appliance with a damp cloth or sponge. Wipe dry with a soft dry cloth.
- Wash the cup in warm, soapy water, then rinse and dry thoroughly.

Tips:

Use a small brush (not included) to remove particles of food lodged underneath the stirrer and cup.

If some leftover particles dry onto the inside of the cup, fill the cup with warm water to MAX mixture level and install the cup onto the appliance. Operate the appliance for about 20-30 seconds to help loosen the stuck ingredients. Repeat the above step but use clean tap water. Empty milkshake maker and dry thoroughly.

- Make sure all components are clean and dried thoroughly before storing.
- Store the appliance upright in a clean and dry location.

TECHNICAL SPECIFICATION

Voltage: 220-240V~ 50-60Hz

Power: 65W

Capacity: MIN MIXTURE: approx.100mL

MAX MILK: approx.200mL

MAX MIXTURE: approx.320mL

12 Month Warranty

Thank you for your purchase.

Your new product is warrantied to be free from defects in materials and workmanship for the period stated above, from the date of purchase, provided that the product is used in accordance with accompanying recommendations or instructions where provided. This warranty is in addition to your rights under the Australian Consumer Law.

For New Zealand customers, this warranty is in addition to statutory rights observed under New Zealand legislation.

We will provide you with your choice of a refund, repair (where possible) or exchange (availability dependent) for this product if it becomes defective within the warranty period. The business will bear the reasonable expense of claiming the warranty.

This warranty will no longer apply where the defect is a result of alteration, accident, misuse, abuse or neglect.

Please retain your receipt as proof of purchase and contact our Customer Service Centre as listed below, for the entity you purchased this product from, for any difficulties with your product. Warranty claims and claims for expense incurred in returning this product can be addressed to the respective Customer Service Centre.

Our goods come with guarantees that cannot be excluded under the Australian Consumer Law. You are entitled to a replacement or refund for a major failure and compensation for any other reasonably foreseeable loss or damage. You are also entitled to have the goods repaired or replaced if the goods fail to be of acceptable quality and the failure does not amount to a major failure.

Contact for Kmart purchases	Contact for Target purchases
Kmart Australia Ltd. C/- Customer Service Centre 690 Springvale Road, Mulgrave Vic 3170 Customer Service: 1800 124 125 (Australia) or 0800 945 995 (New Zealand) or via Customer Help at kmart.com.au	Target Australia Pty Ltd C/- Customer Service Centre 2 Kendall Street, Williams Landing, Vic, 3027 Customer Service: 1300 753 567 or via Customer Help at target.com.au/help/contact-us