

LIGHTUP INLINE SCOOTER INSTRUCTIONS

K: 43419395 | T:69508158

WARNING! Assembly by an adult.

WARNING! Not suitable for children younger than 3 years old, danger of falling.

WARNING! Protective equipment should be worn.

WARNING! Not for children with a body mass of more than 50kg.

This product complies with EN 14619 Class A.

Remove the scooter and all the parts from the box. Set out all the parts and read the assembly instructions prior to use. Keep the packaging until assembly is complete.

General instructions

- This scooter must be assembled by a responsible adult. Prior to use, make sure that the scooter has been assembled properly. Remove all the parts which are not necessary for play before giving the scooter to your child. Due to the skill it requires, the scooter must be used with care in order to avoid falls or collisions likely to injure the user or others.
- To use with a suitable protective equipment, including a helmet, shoes, elbow, wrist and knee protectors. Teach the child how to use it safely and responsibly.
- The scooter is not a toy for children under the age of 3 years.

Directions

- a) The scooter can be dangerous and can lead to traffic accident when used on public highways.
- b) Ride outdoors in places that allow you to improve your skills, and NEVER in traffic, on roads or near motor vehicles, where serious accidents can happen. Watch your surroundings for pedestrians, bike, skateboard, scooter and other riders. Use in areas free from hazards such as poles, hydrants and parked cars.
- c) It is best used on a flat, clean surface, free of gravel and grease.
- d) Avoid bumps and drainage grates that may cause an accident.
- e) The scooter does not include any headlights. It is therefore not suited for use at night or during periods when visibility is limited.
- f) Always use under adult supervision.
- g) Do not allow more than one child to ride the scooter at the same time.

Before and after use

- To prevent pinched fingers, keep your hands on the outside of the handlebar and the footrest when opening and closing the scooter. Make sure that all locking mechanisms

are securely locked:

- Check the height of the steering system, and make sure the nuts are tightened and that the handlebars and the front wheel are perpendicular.
- Check all of the connection elements: the brake, the quick release system of the steering column and the wheel axles must be adjusted correctly and not damaged.
- Also check the wheel wear.

During use

- Standing on the scooter, one hand on each handle, push with one of your feet to move forward. Proceed with caution at the start.
- Braking: a brake is located at the rear, when necessary, press down on it to slow down. Press down gradually in order to prevent skidding or loss of stability. The metal or aluminum brake may heat up after multiple uses. Avoid touching it during and after use.
- Shoes are mandatory and we strongly advise you wearing pants and long sleeve shirts to avoid injury if you fall.
- Explain to the child clearly how to open/close and especially how to lock the scooter before any use.

Assembly Instructions:

1) The scooter folding and unfolding operations are to be performed by an adult.

2) During these operations, be careful not to pinch your fingers in the hinge and locking system.

3) Make sure that all the locking mechanisms are securely locked.

1. HOW TO UNFOLD THE SCOOTER

Step 1:

Loosen the quick release (Open position). Pull the plastic lever up until the quick release pin comes out of its position, then tighten the quick release (Close position). To adjust the tension of the quick release, tighten or loosen the release nut in open position.

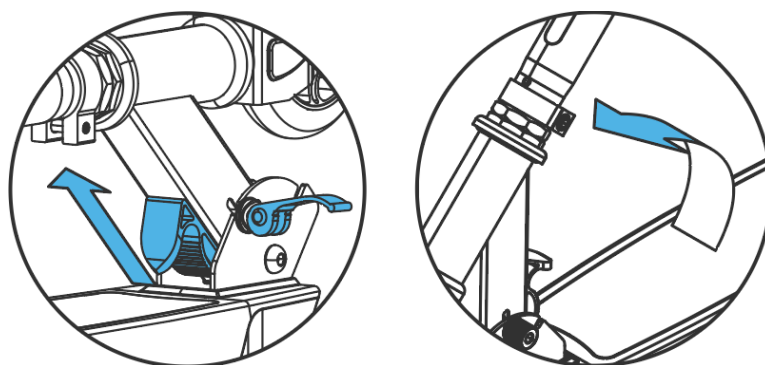

Step 2:

Open quick lock and pull the steering bar until the bullets land in the notch, this scooter only has 3 notches can adjust as below image arrow shows. Then close the quick lock. Clamp or loosen the fast lock by tightening or loosening the locknut on the open-mode.

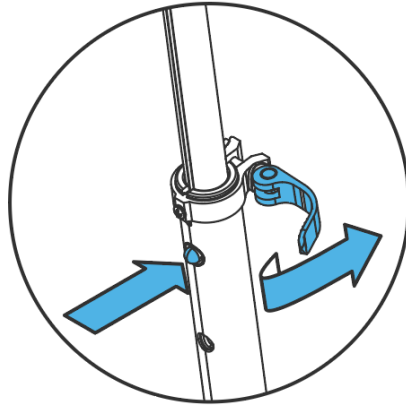

Step 3:

Loose the bolt and nut from adjustable column. Put the handlebar into the adjustable column. Insert the bolt and nut, using the allen key (provided) to tighten. Ensure the handlebar is fully tightened before use.



2. HOW TO FOLD THE SCOOTER TOGETHER

Step 1:

Open quick lock and press the steering rod inwards. Lower the upper part of the steering rod. Then close the quick lock.

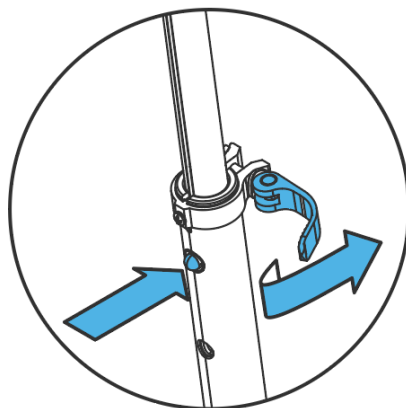

Step 2:

Loosen the quick release (Open position). Pull the plastic lever up and lower the steering column backward until it clips into position, then tighten the quick release (Close position).

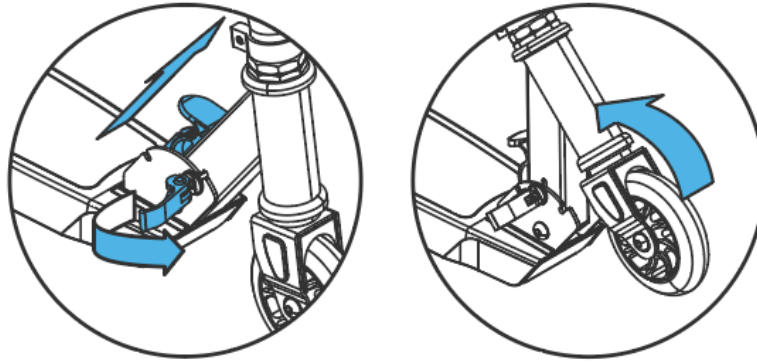

DO NOT FORGET TO REGULARLY TIGHTEN CONTROL BLOCKS SO THAT YOU WILL NOT LOSE THE LOCKING PIN OR SCREW.

3. HOW TO LIGHT UP YOUR SCOOTER

The lights in the wheels of this scooter are motion activated, no batteries are required. When the scooter is not in use the wheels remain clear and do not light up. When the scooter is in use, the wheels light up with blue, red and green lights and will continue to remain on while the scooter is being ridden and in motion.

The lights in the deck:

Step 1: Turn over footplate of the scooter. The battery box is underneath the scooter.

Step 2: Press the switch button once and will light up your deck.

Step 3: Press the switch button to change the flashing effect. The deck contains 7 mode flashing effects.

Step 4: Press the switch button again to turn light off.

4. INSERTING/CHANGING BATTERIES

Batteries not included. You need to prepare 3 X AA (1.5V) batteries.

Step 1: Use a small screwdriver to loosen screw on battery compartment cover on underside of deck and then release the cover.

Step 2: Insert/replace 3 X AA (1.5V) batteries as per the polarity diagram signified in the battery compartment.

Step 3: After batteries are inserted/changed, place the cover back onto the battery compartment and screw again to firmly secure the cover.

WARNINGS: Insert batteries with the correct polarity and always follow the manufacturer's instructions.

Do not mix new and used batteries or alkaline, standard (carbon-zinc), or rechargeable (nickel-cadmium) batteries.

Remove batteries if product will be stored for an extended period.

Dispose of used batteries responsibly.

Care Instructions

A. Wheel bearings: Avoid going through water, oil or sand as this can damage wheel bearings.

To look after the wheel bearings, systematically check that the wheels turn properly by turning the scooter upside-down and using your hand to spin the wheels. If the wheels do not spin they must then be removed to check their condition. First unscrew the wheel axle, remove the axle and detach the wheel, then carefully push the two wheel bearings out of their housing. If they are chipped or dented, new ones should be bought. If there is no visible damage, they must then be oiled. To do this, remove all traces of grease, mud or dust with a kitchen towel or cloth, and re-oil them with a grease spray or by leaving them to soak overnight in oil [turn them several times in the oil first]. Remove reassemble the wheel bearings and axles, followed by the wheel, onto the scooter. Proceed in the same manner for the other wheel.

B. Wheels: The wheels wear down with time and can be pierced if overly used on rough surfaces. The back wheel on which the brake is applied is particularly affected after several hours of braking. In the interests of safety, they should be checked regularly and changed if necessary.

C. Modifications: The original product must by no means be modified except for the maintenance-related changes mentioned in these instructions.

D. Nuts and axles: These should also be checked regularly. They can become loose after a while in which case they should be tightened. They can become worn and not tightened properly, in which case they should be replaced.

MADE IN CHINA

CUSTOMER SERVICE:

KMART AU: 1800 124 125

KMART NZ: 0800 945 995

TARGET AU: 1300 753 567