

43456512

WOODEN MARKET STALL WITH
CASH REGISTER

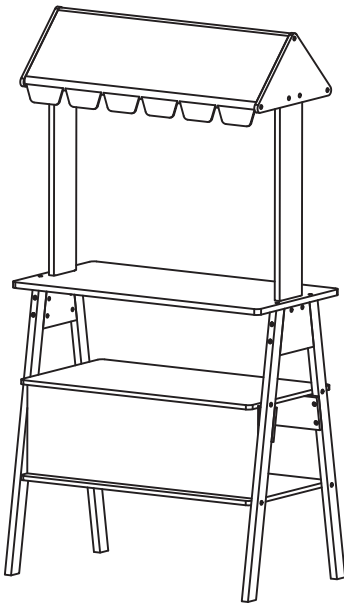

THE INSTRUCTIONS CONTAINS IMPORTANT INFORMATION, PLEASE KEEP IT.

WARNING: ADULT ASSEMBLY IS REQUIRED. UNASSEMBLED PARTS CONTAIN SCREWS AND WITH FUNCTIONAL SHARP POINTS, PLEASE KEEP UNASSEMBLED PARTS AWAY FROM SMALL CHILDREN.

CAUTION: PLEASE CHECK CONDITION OF PRODUCT REGULARLY, AS SCREWS MAY LOOSEN WITH USE OVER TIME. TIGHTEN SCREW FITTINGS IF NECESSARY.









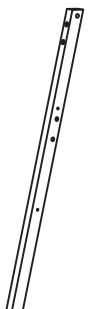

WARNING: BUTTON CELL BATTERIES ARE HAZARDOUS (NEW OR USED). KEEP AWAY FROM CHILDREN. BUTTON CELL BATTERIES CAN CAUSE SEVERE OR FATAL INJURIES IN 2 HOURS OR LESS IF THEY ARE SWALLOWED OR PLACED INSIDE ANY PART OF THE BODY. IF YOU SUSPECT YOUR CHILD HAS SWALLOWED OR INSERTED A BUTTON CELL BATTERY, CALL THE 24-HOUR POISONS INFORMATION CENTRE IN AUSTRALIA ON 131126 OR IN NEW ZEALAND 0800 764 766 OR CONTACT YOUR COUNTRY'S EMERGENCY DEPT.







THIS PRODUCT CONTAINS
BUTTON CELL BATTERIES
SCAN THE QR CODE FOR
MORE INFORMATION.

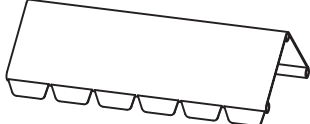

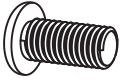
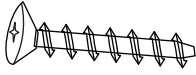
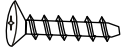
CONTAINS NON-REPLACEABLE
BUTTON CELL BATTERIES

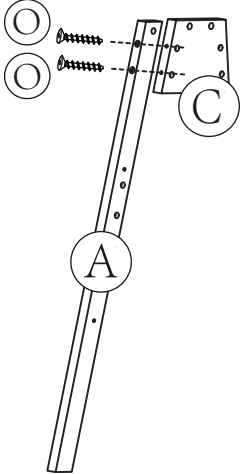
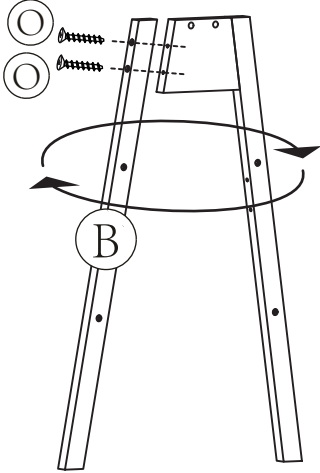
A  x2	B  x2	C  x2	D  x1
E  x1	F  x1	G  x1	H  x2
I  x2	J  x2	K  x3	L  x1

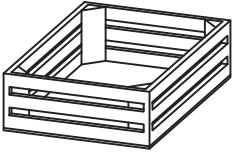
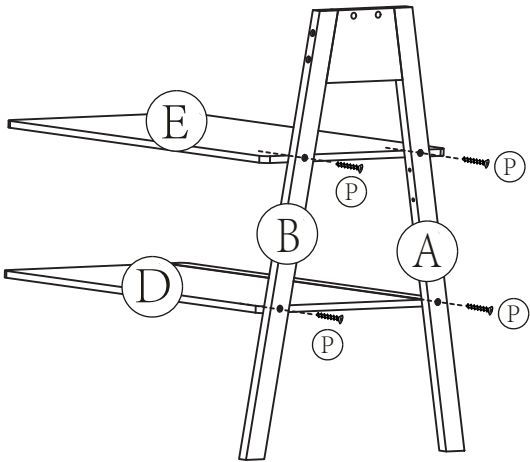
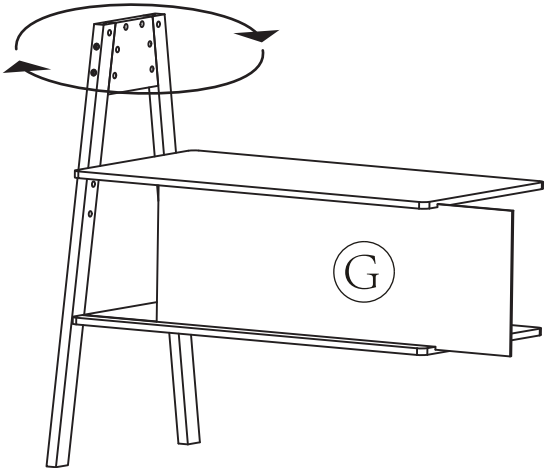
<p>M</p>  <p>x8</p>	<p>N</p>  <p>x8</p>	<p>O</p>  <p>4x50mmx8</p>	<p>P</p>  <p>4x35mmx12</p>
<p>Q</p>  <p>4x30mmx14</p>	<p>1</p>  <p>x2</p>		<p>2</p>  <p>x2</p>
<p>R</p>  <p>x1</p>			
<p>S</p>  <p>x3</p>			
<p>3</p> 		<p>4</p> 	

5

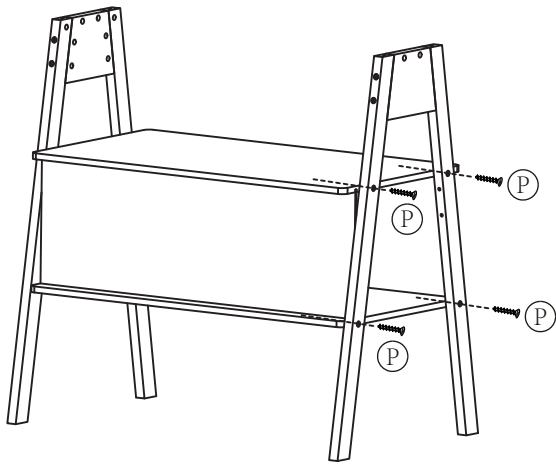

6

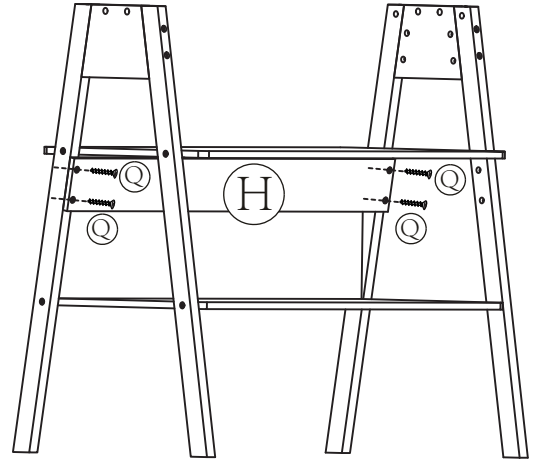

7

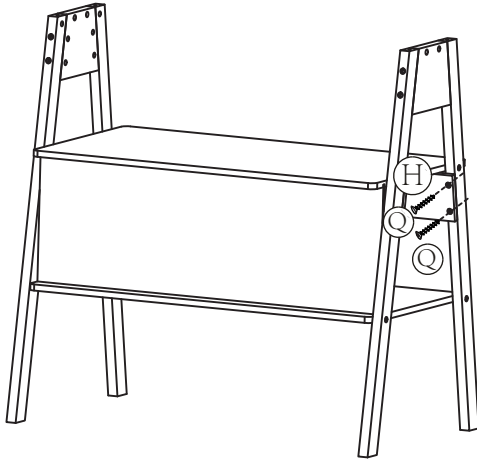

8

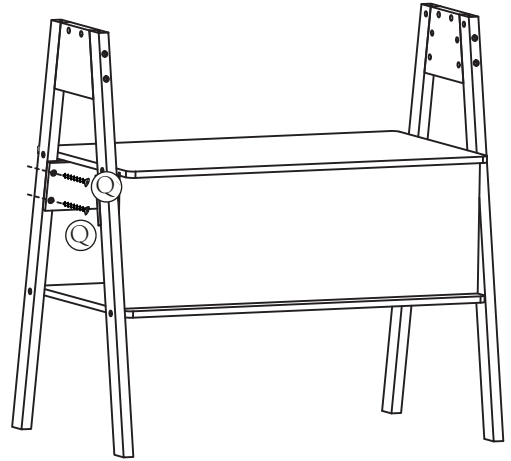

9

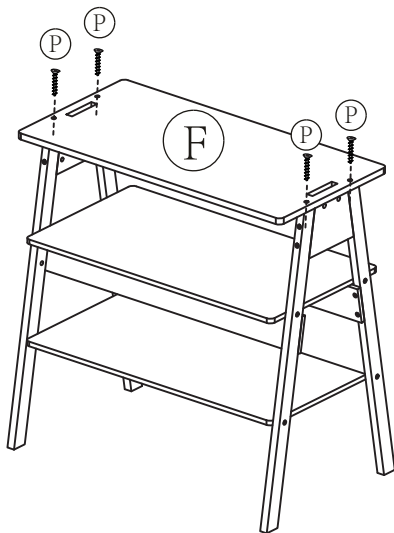

10

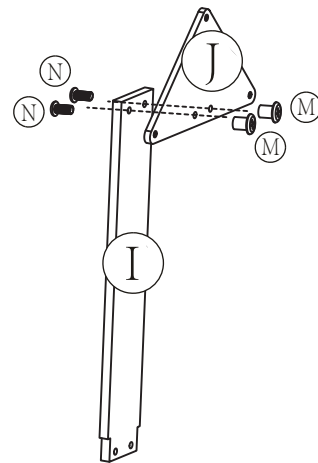

x2

11

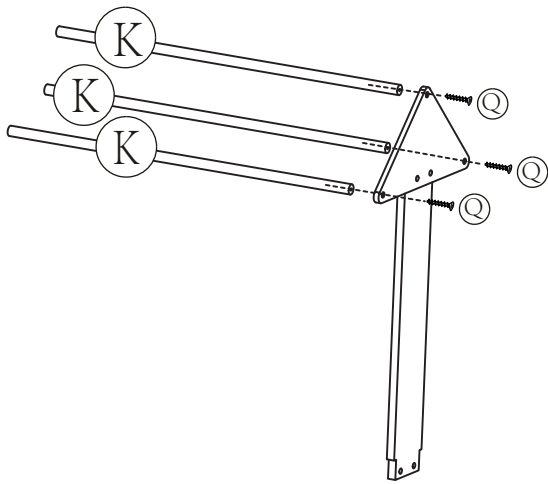

12

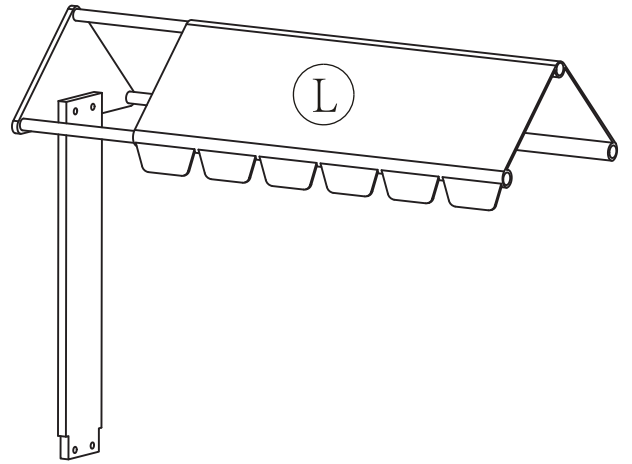

13

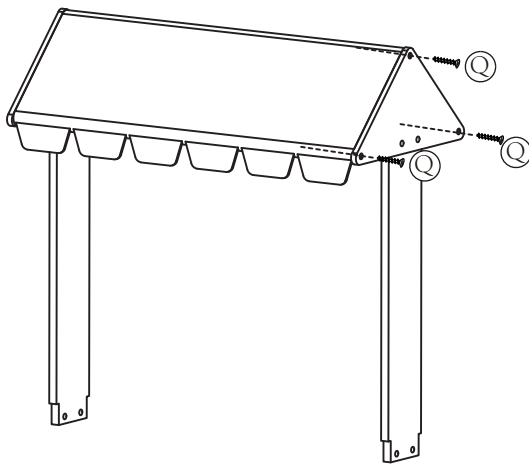

14

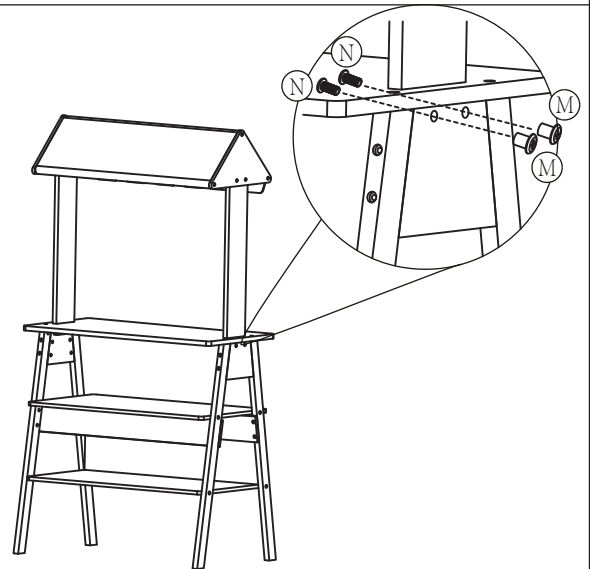

15

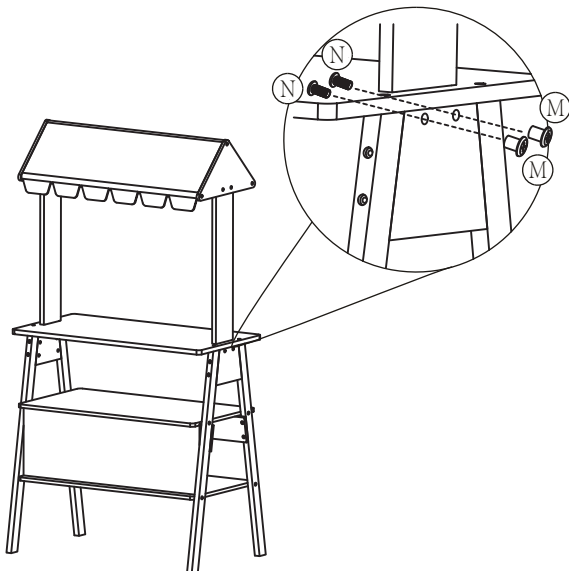

16

