

# anko

## Handheld Spot Cleaner

### For Household Use Only



Model No.: DMW005  
Rev 1

**Note:** The specifications and/or components of this appliance are subject to change without prior notice.

If any Accessories should fail during use, please call 1300 105 888 (Australia) or 09 8870 447 (New Zealand) for an immediate replacement. This will save you from returning the product to the store.

If we can assist you in any other way, please feel free to contact us.



<b>1</b>	<b>Warnings</b> .....	<b>5</b>
<b>2</b>	<b>Components</b> .....	<b>8</b>
<b>3</b>	<b>Instructions for Use</b> .....	<b>9</b>
	3.1 Floor Surfaces.....	9
	3.2 Carpet Cleaning Solution .....	9
	3.3 Charging the Appliance.....	10
<b>4</b>	<b>Using the Spot Cleaner</b> .....	<b>12</b>
	4.1 Filling with Water / Cleaning Solution .....	12
	4.2 Dirty Water Tank .....	14
	4.3 Switching Power On and Off.....	15
	4.4 Switching Rotary Floor Brush On and Off .....	15
	4.5 Switching Spray On and Off.....	16
<b>5</b>	<b>Operation</b> .....	<b>16</b>
<b>6</b>	<b>User Maintenance</b> .....	<b>17</b>
	6.1 Emptying and Cleaning the Dirty Water Tank.....	17
	6.2 Cleaning the Clean Water Tank .....	18
	6.3 Cleaning the Dirty Water Suction Chute .....	19
	6.4 Cleaning the Floor Head / Rotary Brush .....	20
	6.5 Cleaning the Main Unit .....	21
<b>7</b>	<b>Storage</b> .....	<b>21</b>
<b>8</b>	<b>Troubleshooting</b> .....	<b>22</b>
<b>10</b>	<b>Warranty Against Defect</b> .....	<b>23</b>



# 1 Warnings

When using electrical appliances, basic safety precautions should always be followed, including the following:



Carefully read this instruction manual before use.

- Keep the Appliance and USB cable out of reach of young children.
- This appliance is not intended for use by persons (including children) with reduced physical, sensory, or mental capabilities, or lack of experience and knowledge, unless they have been given supervision or instruction concerning use of the appliance by a person responsible for their safety.
- Children should be supervised to ensure that they do not play with the Appliance and/or USB cable.
- Ensure children and babies do not play with plastic bags or packaging materials.
- Do not use on people or pets etc.
- Do not disassemble the Appliance and/or USB cable. There are no user serviceable parts inside.
- **VERY IMPORTANT:**  
Ensure that the Appliance and/or USB cable does not get wet (water splashes etc.).  
Do not use your charger, Appliance, or the USB cable with wet hands.  
Do not immerse the Appliance and/or the USB cable in water or other liquids.
- Only Charge the Appliance with the USB cable that was supplied with the Appliance.
- Only Charge the Appliance from an Extra Low Voltage Battery Charger (not supplied) with an output rating the same as indicated on the Appliance's rating label.
- Position the USB cable properly so that it will not be walked on or pinched by items placed on or against it.
- Use the Appliance and USB cable only for its intended use. The Appliance and USB cable are intended for household use only and not for commercial or industrial use.
- Inspect the USB cable and Appliance for damage prior to every use.
- Do not use the Appliance if it has been dropped or any part of the Appliance and/or the USB cable has been damaged.
- If the USB cable is damaged, call our customer service for a replacement.

- The use of accessories not intended for use with this the Appliance may cause injuries to the user or damage to the Appliance and/or the USB cable.
- Do not sit the Appliance on other appliances, on uneven surfaces or where it could be subject to heat sources (e.g., radiators or stoves), direct sunlight, excessive dust, or mechanical vibrations.



The Appliance and/or USB cable must not be used outdoors if raining, placed near a hot gas or electrical burner or placed in a heated oven.

- Do not place or leave near any heat sources such as radiators, heat registers, stoves, or other apparatus that produce heat.
- Do not operate or charge the Appliance underneath or near flammable or combustible materials (e.g., curtains).
- Always switch off and unplug the charger (not supplied) when finished charging the Appliance, or during lightning storms or when unused for long periods of time.
- Do not cover the Appliance or charger when charging or when in use.
- Turn off and unplug before cleaning or storing.
- Any type of servicing, apart from ordinary cleaning, must be carried out by a qualified electrical person only. There are no user serviceable parts in this Appliance.
- Cleaning and user maintenance shall not be made by children without supervision.
- If a third party uses this Appliance and USB cable, please supply the instruction manual with it.
- Do not misuse the USB cable. Never carry the Appliance by the USB cable or pull to disconnect it from the socket. Instead, grasp the plug and pull to disconnect.
- Do not insert or allow foreign objects to enter the charging port as this may cause damage to the Appliance and/or injury to the user.
- **Do not leave the Appliance on or charging unattended.**
- No liability can be accepted for any damage caused by non-compliance with these instructions or any other improper use or mishandling of the Appliance and/or USB cable.
- This product has not been designed for any uses other than those specified in this manual.
- **ONLY** for domestic use. Industrial or commercial use invalidates the warranty.



## **WARNING**

Only use the USB Cable that was supplied with this Appliance.

Battery Pack Specification:

Type: Li-ion, 14.8Vd.c., 2200mAh (Non-Removable or Replaceable).

Input: Requires a 5Vd.c. / 2A Power Adaptor (not supplied).

Consumers are cautioned against trying to replace the battery. Using and/or purchasing counterfeit and/or inferior quality batteries have the potential to cause fire, personal injury, and/or damage to property. These batteries are typically found on online-auction websites or from other retailers and are known to pose a potential safety risk.

- Batteries may explode if disposed of in fire.
- The battery is not replaceable. Do Not open the Appliance.
- Do not use or store in temperatures above 40°C.

At the end of the Appliance's life, it must be disposed of correctly.



This appliance contains a battery that is non-replaceable, and as the battery is non-replaceable, the complete appliance must be recycled as this is where the battery is located.

Contact your local waste management authority for more information on Battery Recycling and disposal regulations in your area.



This symbol on the product or its packaging indicates:

Do not dispose of electrical appliances or batteries as unsorted municipal waste, use separate collection facilities. Contact your local council for information regarding the collection systems available. If electrical appliances are disposed of in landfills or dumps, hazardous substances can leak into the groundwater and get into the food chain, damaging your health and well-being. Please contact your local council or regional authority for more information on collection, reuse, and recycling programmes.

## **Read and Save These Instructions**

## 2 Components



1	Spray Nozzle	5	USB Charging Port
2	Clean Water Tank	6	USB Cable
3	Control Buttons and Indicator Lights	7	Dirty Water Tank
4	Carry Handle	8	Floor Head

Note: The specifications and/or components of this appliance are subject to change without prior notice



### 3 Instructions for Use

This product is Water Resistant to IPX4

#### 3.1 Floor Surfaces

This product can be used for cleaning carpets, mats, rugs, etc.

It is strongly advised to always test a section of the flooring material in an out-of-sight area first to ensure the surface to be cleaned is not damaged by the warm water, cleaning solution used or the rotary scrubbing brush.

Always follow the instructions provided with the cleaning solution. If unsure, **DO NOT USE!**

**IMPORTANT: DO NOT USE** on unsealed hardwood or unglazed ceramic surfaces, etc. Surfaces that are not properly sealed may be warped or damaged by exposure to heat, moisture, and cleaning solutions. **DO NOT** use on furniture or fixtures.

#### 3.2 Carpet Cleaning Solution

**IMPORTANT:** Only use a **Low Foaming** carpet cleaning solution.

Always follow the instructions on the Cleaning Solution Bottle.

**DO NOT** add any other agents into the water tank such as rust removers, odour counter-reacting agents, alcohol, solvents, etc. as this will damage the appliance and may damage the carpet.

Adding other detergents or carpet cleaners that are not Low Foaming, may damage the appliance and will make using the appliance impossible due to the foaming suds.

The Clean Water Tank will hold approx. 240ml of clean water when filled to the "Max" fill line located on the back of the water tank.

**Important:** Check the recommended mixing ratio found in the instructions supplied with the cleaning solution.

The ratio should be calculated based on 200ml of water as adding the solution will make it up to approximately 240ml, (depending on the solution mix ratio).

**Important:** for people who suffer from allergies / asthma, there are special carpet cleaning solutions that can be purchased specifically for allergy / asthma sufferers.

**NOTE:** Add the required amount of cleaning solution to the Water Tank first then fill up with the Hot Water (Maximum 40°C) to the “Max” line located on the back of the water tank.

**Do Not** add more cleaning solution than that specified on the cleaning solution container.

**As a guide:**

**Example 1:**

If your cleaning solution states to mix with a ratio of 25:1 (25 parts water to 1 part cleaning solution) you would calculate this as follows:

Clean Water Tank = 200ml water

$$200 \div 25 = 8$$

Solution = 8ml.

Therefore: add 8ml of Cleaning Solution to the Clean Water tank and then fill up with hot water (Maximum 40°C) to the “Max” line located on the back of the water tank.

**Example 2:**

If your cleaning solution states to mix with a ratio of 15:1 (15 parts water to 1 part cleaning solution) you would calculate this as follows:

Clean Water Tank = 200ml water

$$200 \div 15 = 13.3$$

Solution = 13ml.

Therefore: add 13ml of Cleaning Solution to the Clean Water tank and then fill up with hot water (Maximum 40°C) to the “Max” line located on the back of the water tank.

### 3.3 Charging the Appliance

**Read the Safety Instruction first.**

**IMPORTANT:** This Appliance contains a built-in lithium-ion battery pack which must only be charged using the supplied USB cable.

Always switch off and unplug the USB cable when charging is completed or when not in use.

**NEVER LEAVE THE APPLIANCE UNATTENDED WHEN CHARGING.**

If any abnormality occurs during charging, (such as a burning smell or excessive heat or even a strange sound) immediately turn off the charger and disconnect the USB cable, then contact our service department for assistance.

**NOTE:** The Appliance must be fully charged prior to first use.

Normal charging time will take approx. 6 hours using a 5Vd.c. 2A charger.

The appliance cannot be used during charging. The USB cable must be removed from the appliance before turning on.

- First, remove the Rubber plug that is sealing the charging port on the rear side of the appliance by pulling the tab on the plug up and out to access the USB charging socket as shown.

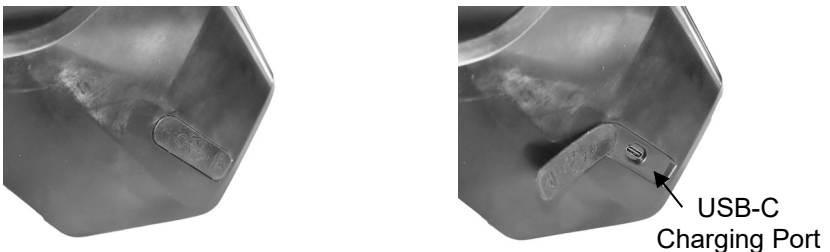

- Take the USB Cable and fully unravel it before using to charge the Appliance.
- Plug the small end of the USB cable directly into the Charging Port on the appliance.

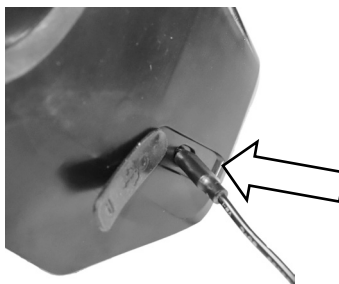

- Plug the large end of the USB cable into your 5Vd.c. charger, then switch on the charger.

- The indicator light underneath the Control Buttons on the handle will indicate when the battery is charging.

There are three light segments that will “roll” left to right indicating charging.

As the battery charges to approximately 33%, the first segment light will turn permanently on, then as the battery continues to charge to approximately 66%, the second light segment will turn permanently on, and then as the battery continues to charge to 100%, the third light segment will turn on and all lights will remain on until unplugged.

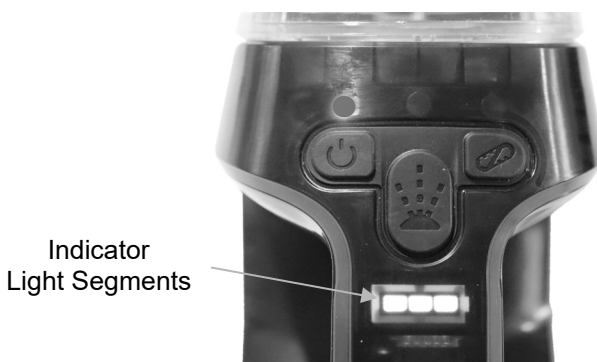

- At this time, remove the USB charging cable and turn off & unplug the charger.

**DO NOT** leave the unit charging when the battery is full.

## 4 Using the Spot Cleaner

**Warning:** Always wear rubber gloves and safety glasses for personal protection during use.

### 4.1 Filling with Water / Cleaning Solution

**IMPORTANT:** Only use a **Low Foaming** carpet cleaning solution.

Always follow the instructions on the Cleaning Solution Bottle.

**NOTE:** For best performance, use hot tap water up to a maximum of 40°C.

Before use, please refer to the sections “Floor Surfaces” and “Carpet Cleaning Solution” in this manual.

- Remove the Clean Water Tank by grasping the lower part of the tank then pull the water tank straight out and roll upwards to unlatch.



- Position the Water Tank so that the water filling hole is facing upward then remove the rubber plug from the filling hole by lifting the bottom edge first then rotate the plug sideways to access the filling hole.



- Add the recommended amount of cleaning solution (specified on the Cleaning Solution Container) to the water tank and then fill with hot tap water (maximum 40°C) up to the “Max” line marked on the back of the water tank.

**NOTE:** Refer to the section “**Carpet Cleaning Solution**” in this manual for instructions on calculating the amount of carpet cleaning solution based on the solution you have purchased and then adding it to the tank.

**IMPORTANT:** Only use a **Low Foaming** carpet cleaning solution and always follow the instructions on the Cleaning Solution Bottle.

**DO NOT** add any other agents into the water tank such as rust removers, odour counter-reacting agents, alcohol, solvents, etc. as this will damage the appliance and may damage the carpet.

- Push the Rubber plug back it to the filling hole ensuring it is sealed properly.



- Refit the water tank to the main unit by hooking in the top of the tank first then roll down and push in until it seats in place.



#### 4.2 Dirty Water Tank

- Remove the Dirty Water Tank by sliding the latch down to unlatch as shown and pull the tank out.



Ensure the Dirty Water Tank's rubber plug is fitted and sealing correctly and then reattach to the main unit ensuring it is clipped in place.

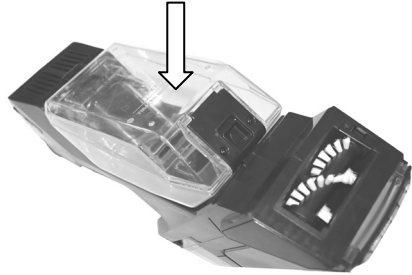
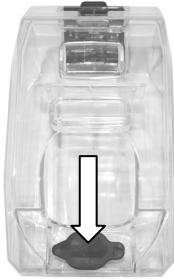

**Note:** You must clean all water tanks and components after each use. Refer to the “User Maintenance” section in this manual on how to do this. Always turn the unit Off when carrying from room to room.

### 4.3 Switching Power On and Off

- Press and release the On/Off button (located at the top of the handle) to turn the vacuum motor and the indicator light on.

To turn off, press and release the On/Off button and the vacuum motor and the indicator light will turn off.

**Note:** this will also turn off all other functions.



### 4.4 Switching Rotary Floor Brush On and Off

- With the Vacuum Motor running, press and release the Rotary Floor Brush button to turn the rotary brush motor and indicator light on.

To turn the rotary floor brush off, press and release the Rotary Floor Brush button again and the rotary brush motor and indicator light will turn off.

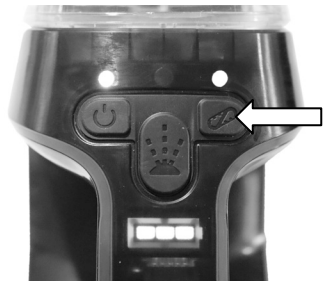

## 4.5 Switching Spray On and Off

- With the Vacuum Motor running, press and hold the Spray button to pump cleaning solution out of the spray nozzle. The indicator light will turn on.

To turn the spray off, release the spray button. The pump and indicator light will turn off.



## 5 Operation

- Turn on the Vacuum Motor and Rotary Floor Brush as described previously then position the front of the unit over the area to wet with the cleaning solution.
- Press and hold the Spray button to pump cleaning solution out of the spray nozzle to spray a fan of cleaning solution over the area chosen to be cleaned.
- When you have applied the desired amount of cleaning solution to the carpet, release the button and the spray will stop.

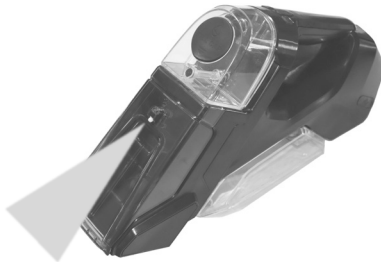

- With the rotary brush rotating, gently massage the wetted dirty area with a back and forward motion.

**IMPORTANT:** do not scrub hard, gently massage the carpet.

**NOTE:** If too much downward pressure is applied, the rotary brush will jam, and this will turn off the appliance.

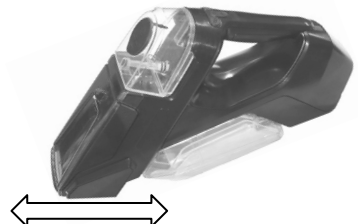



- After scrubbing is complete, turn the Rotary Brush off and with the front tip of the floor head pushed gently into the carpet, move the floor head back and forward slowly over the entire area that was applied with the cleaning solution to allow the dirty water to be sucked up.



- Repeat the process if more cleaning is required.

**NOTE:** The Dirty Water Tank has a “Max Full” line to visually indicate when the tank needs emptying.

Do Not allow the Dirty Water to pass the Max Full line before emptying.

## 6 User Maintenance

**WARNING:** The appliance must be switched off and must not be charging during any maintenance, cleaning, filling the Clean Water Tank or emptying the Dirty Water Tank, etc.

**NOTE:** Cleaning and User Maintenance shall not be made by children without supervision

### 6.1 Emptying and Cleaning the Dirty Water Tank

- Empty the Dirty Water Tank before the water level reaches the “MAX FULL” line, and after every use.
- Remove the Dirty Water Tank as described under the section “Dirty Water Tank”.

**IMPORTANT:** Hold the Dirty Water Tank upright after removing and do not tip sideways or forward or backward as the dirty water will spill out.

- Take the dirty water tank to the sink and pull out the rubber plug.



- Empty the dirty water and remove any debris that may be caught inside.
- Wash out the tank with warm water and mild dishwashing detergent and rinse.

**DO NOT** place in a dishwasher.

**DO NOT** use a hairdryer or place it in an oven to dry the components.

- Refit the rubber plug making sure it is sealing properly and then refit the dirty water tank to the main unit.

**Important Note:** Never use abrasive cleaners, solvents, steel wool, scouring pads, stiff brushes, or strong chemicals that might or might not be flammable and/or damaging to the product.

## 6.2 Cleaning the Clean Water Tank

- Remove the Clean Water Tank as described under the section “Filling with Water / Cleaning Solution”.
- Take the clean water tank to the sink and pull out the rubber plug.



- Wash out the tank with warm water and mild dishwashing detergent and rinse.

**DO NOT** place in a dishwasher.

**DO NOT** use a hairdryer or place it in an oven to dry the components.

- Refit the rubber plug making sure it is sealing properly and then refit the clean water tank to the main unit.

**Important Note:** Never use abrasive cleaners, solvents, steel wool, scouring pads, stiff brushes, or strong chemicals that might or might not be flammable and/or damaging to the product.

### 6.3 Cleaning the Dirty Water Suction Chute

- To clean the Dirty Water Suction Chute on the front of the unit, remove the transparent cover from the main unit as follows:
- First remove the Clean Water Tank, then remove the transparent cover by prying the locking tab up and forward then swing the cover forward and off as shown.

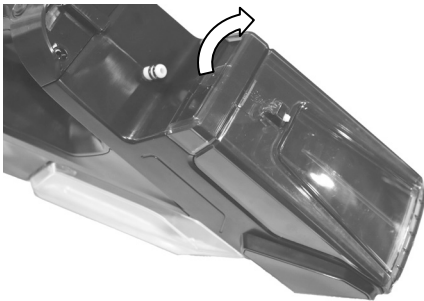

- Wash the cover in warm water (40°C or less) with mild dishwashing detergent then rinse in clean cold water and allow too completely dry.

**DO NOT** place in a dishwasher.

**DO NOT** use a hairdryer or place it in an oven to dry the components.

- Clean the front of the main unit with a damp cloth.

**DO NOT immerse any of the main unit in water.**

- Reassemble the front cover by hooking it onto the lower front of the floor head, swing it back and then push down firmly until the tab clips shut.

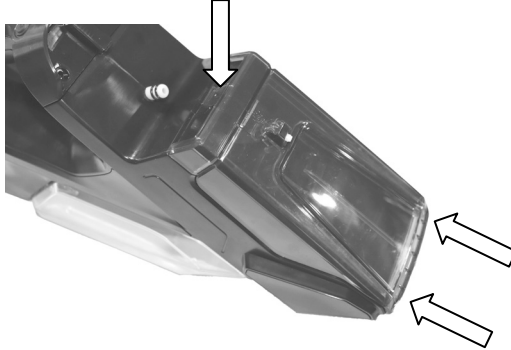

#### 6.4 Cleaning the Floor Head / Rotary Brush

To clean the rotary brush and brush compartment, the rotary brush needs to be removed first as follows:

- Lay the unit on its side as shown in image 1.
- Press the release tab downward and at the same time, rotate forward as shown in image 2.

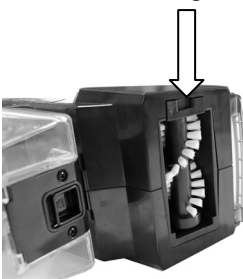

Image 1

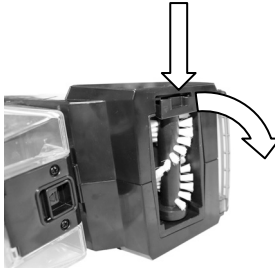

Image 2



- Remove the rotary brush and take to the sink to wash.
- Wash the brush in warm water (40°C or less) with mild dishwashing detergent then rinse in clean cold water and allow too completely dry.

**DO NOT** place in a dishwasher.

**DO NOT** use a hairdryer or place it in an oven to dry the components.

- Clean the inside of the rotary brush compartment of the main unit with a damp cloth and dry.

**DO NOT immerse any of the main unit in water.**

## 6.5 Cleaning the Main Unit

**CAUTION: DO NOT IMMERSE THE APPLIANCE IN WATER OR LIQUID.**

- Turn off and unplug before cleaning.

**Never use** abrasive cleaners, solvents, steel wool, scouring pads, stiff brushes, or strong chemicals that might or might not be flammable and/or damaging to the product.

- Clean by using a damp (not wet) cloth with mild detergent and wipe over the surfaces.
- Dry thoroughly with a clean cloth.

**DO NOT** place any components in a dishwasher.

- Ensure the USB Charging Port does not get wet.

## 7 Storage

- Switch off and unplug the Appliance.
- Coil the USB cable loosely. Do not kink or pull the cable tight.
- Store your Appliance in a cool, dry location.

## 8 Troubleshooting

Will Not Switch On	Check that the battery is fully charged.	
	The USB cable is still plugged in to the unit.	Remove USB cable.
The appliance keeps turning off when in use.	The battery is flat.	Recharge battery.
	Too much downward pressure is being applied to the floor and is jamming the rotary brush.	Do not force the appliance downward. Allow the unit to work under its own weight.
	The rotary brush is jammed.	Clear away any foreign objects from the rotary brush.
The Battery Indicator lights blinking during use.	This indicates the level of charge left in the battery.	
The Battery Indicator Lights blinks during charging.	This indicates that the battery is still charging.  The battery is fully charged when the light stops blinking and all lights remain on until unplugged.	
No Water is being sprayed.	Power Not Switched On.	Switch Unit On.
	No water / cleaning solution in the clean water tank.	Add water / cleaning solution to the clean water tank.
	The Spray Button is not being held down.	The Spray button needs to be pressed down and held down for the spray to work.
	Check for blockages and unblock.	
<p>If all the above checks out and the unit will still not turn on at all, it could be the internal temperature safety fuse that has been activated.</p> <p>If this occurs, call our customer service department for further instructions.</p>		

# 10 Warranty Against Defect

## 12 Month Warranty

Thank you for your purchase.

Your new product is warranted to be free from defects in materials and workmanship for the period stated above, from the date of purchase, provided that the product is used in accordance with accompanying recommendations or instructions where provided. This warranty is in addition to your rights under the Australian Consumer Law. For New Zealand customers, this warranty is in addition to statutory rights observed under New Zealand legislation.

We will provide you with your choice of a refund, repair (where possible) or exchange (availability dependent) for this product if it becomes defective within the warranty period. The business will bear the reasonable expense of claiming the warranty. This warranty will no longer apply where the defect is a result of alteration, accident, misuse, abuse, or neglect.

Please retain your receipt as proof of purchase and contact our Customer Service Centre as listed below, for the entity you purchased this product from, for any difficulties with your product. Warranty claims and claims for expenses incurred in returning this product can be addressed to the respective Customer Service Centre.

Our goods come with guarantees that cannot be excluded under the Australian Consumer Law. You are entitled to a replacement or refund for a major failure and compensation for any other reasonably foreseeable loss or damage. You are also entitled to have the goods repaired or replaced if the goods fail to be of acceptable quality and the failure does not amount to a major failure.

Contact for Kmart purchases	Contact for Target purchases
Kmart Australia Ltd. C/- Customer Service Centre, 690 Springvale Road, Mulgrave Vic 3170 Customer Service: 1800 124 125 (Australia) or 0800 945 995 (New Zealand) or via Customer Help at <a href="http://kmart.com.au">kmart.com.au</a>	Target Australia Pty Ltd. C/- Customer Service Centre, 2 Kendall Street, Williams Landing, Vic, 3027 Customer Service: 1300 753 567 or via Customer Help at <a href="http://target.com.au/help/contact-us">target.com.au/help/contact-us</a>

**IMPORTANT! For all technical queries or difficulties in operating the product and for spare parts, contact H.E. Group customer service 1300 105 888 (Australia) and 09 8870 447 (New Zealand).**

