

## WAVE FLOOR LAMP

Item no.: WSN8008-63C

T: 70166194  
K: 43464975

### IMPORTANT SAFETY INSTRUCTIONS:

The following safety precautions should always be followed, to reduce the risk of electric shock, personal injury or fire. It is important to read all of these instructions carefully before using the product, and to save them for future reference or new users.

1. This product must only be used as intended in accordance with the enclosed operating instructions
2. Do not carry the appliance by the mains cable or pull the cable to remove the plug from the socket.
3. CAUTION: Electric shock hazard. The external flexible cable, plug or the switch of this lamp cannot be replaced. If any of these parts are damaged, disconnect from mains power. The lamp should be destroyed.
4. If the lamp stops unexpectedly or appears to malfunction, unplug from the mains and stop using immediately. Seek professional advice to rectify the fault or make repairs.
5. Switch off the power supply or unplug from the mains socket when not in use, before cleaning or changing accessories.
6. Avoid positioning the lamp where the power cable might be accidentally trapped or damaged.
7. Keep the lamp and cable away from sources of heat, sharp objects or anything that may cause damage.
8. Ensure the lamp is switched OFF before connecting to the mains power supply.
9. Be aware that some surfaces may become hot. Do not touch hot surfaces and supervise others accordingly.
10. This product has not been designed for use by children.
11. Children should be closely supervised at all times when they are near any electrical appliance.
12. To protect against electric shock, never allow the lamp, the mains cable or plug to come into contact with water or any other liquid.
13. Never reach for any appliance that has fallen into water. Switch off the power supply at the mains immediately and unplug. Do not re-use until the product has been inspected and approved by a qualified electrician.
14. Always ensure that hands are dry before operating or adjusting any switch on the product or touching the plug and mains supply connections.
15. To disconnect, first ensure that all controls are in the OFF position, then remove the plug from the electricity supply.
16. Where relevant keep all ventilation slots, filters, etc. uncovered and clear of debris. Never drop or insert objects into the openings.
17. Do not use outdoors. This lamp has been designed for domestic indoor use only.

### ADDITIONAL SAFETY PRECAUTIONS FOR LIGHTING:

1. Carefully read all instructions for the assembly and use of this product before connecting to an electricity supply.
2. Use only the recommended bulb rating, as detailed on the lamp holder and / or label.
3. Never use a bulb that is rated more than the recommended capacity.
4. Light bulbs become very hot in seconds. Do not attempt to touch the bulb while the lamp is lit and supervise others accordingly.
5. Before cleaning or replacing a defective bulb, switch off the lamp and unplug from the mains socket. Allow the bulb to cool for at least 10 minutes before touching it and making the change.
6. Ensure the new bulb is secure in the holder before reconnecting to the power supply.
7. If in doubt, consult a qualified electrician.

### Product Specification:

- Rated Voltage: 220-240V ~ 50Hz
- Bulb requires: Max 25W E27 Edison Screw (Not Included)  
7 - 9W LED recommended for medium brightness

### INSTRUCTION FOR INSTALLATION:

1. Caution: Assemble the lamp completely before connecting to the electricity supply.
2. Take out the cardboard from the base and the PP bag from the poles (B), fix 4 parts of poles one by one.
3. Use nut (C), washers (E) & (F) fix poles to base.
4. Loosen the socket ring.
5. Install the lampshade (A) to the lamp holder and lock the socket ring.
6. Install the bulb Max 25W E27 (not included) into the Lamp Holder.
7. Check to ensure that all the components have been assembled correctly.
8. Connect to the mains supply.

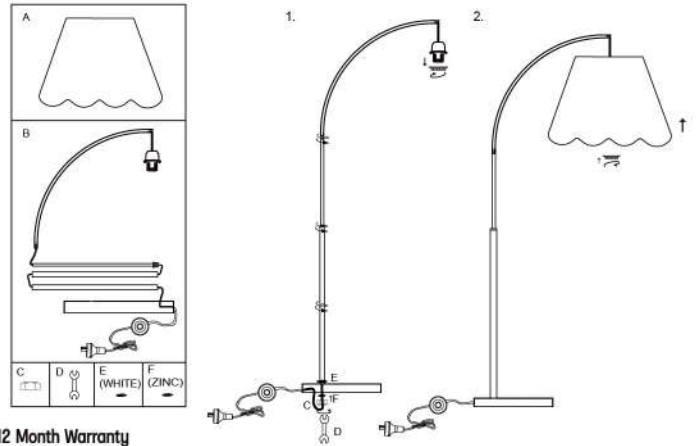

### 12 Month Warranty

Thank you for your purchase.

Your new product is warranted to be free from defects in materials and workmanship for the period stated above, from the date of purchase, provided that the product is used in accordance with accompanying recommendations or instructions where provided. This warranty is in addition to your rights under the Australian Consumer Law. For New Zealand customers, this warranty is in addition to statutory rights observed under New Zealand legislation.

We will provide you with your choice of a refund, repair (where possible) or exchange (availability dependent) for this product if it becomes defective within the warranty period. The business will bear the reasonable expense of claiming the warranty. This warranty will no longer apply where the defect is a result of alteration, accident, misuse, abuse or neglect.

Please retain your receipt as proof of purchase and contact our Customer Service Centre as listed below, for the entity you purchased this product from, for any difficulties with your product. Warranty claims and claims for expense incurred in returning this product can be addressed to the respective Customer Service Centre.

Our goods come with guarantees that cannot be excluded under the Australian Consumer Law. You are entitled to a replacement or refund for a major failure and compensation for any other reasonably foreseeable loss or damage. You are also entitled to have the goods repaired or replaced if the goods fail to be of acceptable quality and the failure does not amount to a major failure.

Contact for Kmart purchases	Contact for Target purchases
Kmart Australia Ltd. C/- Customer Service Centre 690 Springvale Road, Mulgrave Vic 3170 Customer Service: 1800 124 125 (Australia) or 0800 945 995 (New Zealand) or via Customer Help at <a href="http://kmart.com.au">kmart.com.au</a>	Target Australia Pty Ltd C/- Customer Service Centre 2 Kendall Street, Williams Landing, Vic, 3027 Customer Service: 1300 753 567 or via Customer Help at <a href="http://target.com.au/help/contact-us">target.com.au/help/contact-us</a>