

# Instruction Manual

## Double 3 Tier Airer





K:43-465-972 | T:70-171-754

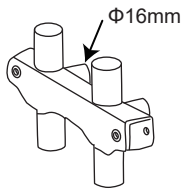
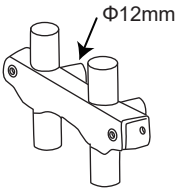
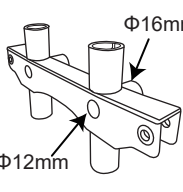
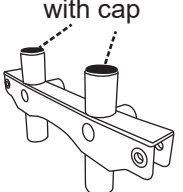
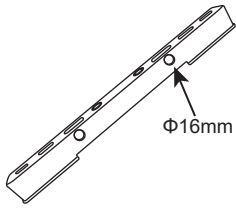
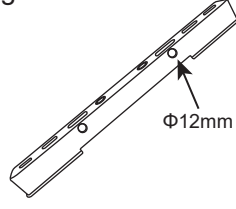
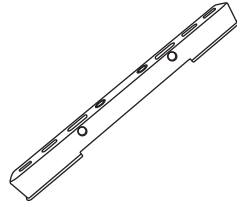

**CARE INSTRUCTION:** WIPE CLEAN WITH A SOFT DRY OR DAMP CLOTH. KEEP AWAY FROM WATER AND DIRECT SUNLIGHT. FOR INDOOR AND DOMESTIC USE. CHECK AND TIGHTEN ALL PARTS REGULARLY.

**WARNING:** DO NOT STAND ON THE UNIT. DO NOT LEAN ON THE PRODUCT. DO NOT USE UNTIL ALL SCREWS, BOLTS AND KNOBS ARE FIRMLY SECURED. THIS PRODUCT CONTAINS SMALL PARTS AND SHARP POINTS, KEEP AWAY FROM CHILDREN AND BABIES. ADULT ASSEMBLY REQUIRED. FAILURE TO FOLLOW THESE WARNINGS COULD RESULT IN SERIOUS INJURY.

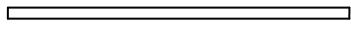
**MAXIMUM LOADING WEIGHT OF:** EACH HANGER:1KG; EACH SHELF 2KG; EACH MIDDLE PART:2KG.

## Hardware list

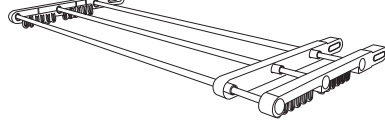
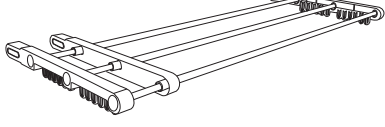
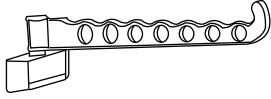
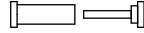
			
A x 3PCS	B x 3PCS	C x 2PCS	D x 1PC
			
Left base	Right base	Middle base	
E x 1PC	F x 1PC	G x 1PC	
			H x 6PCS
Φ16x630mm+Φ12x660mm extend pipe			
			I x 18PCS
Φ19x500mm			
			J x 2PCS
Φ16x680mm+Φ12x700mm			

					
K1 x 3PCS	K2 x 3PCS				
					
L x 2PCS					
	M x 18PCS Reminder:2sets extra parts		N1 x 3PCS		N2 x 3PCS

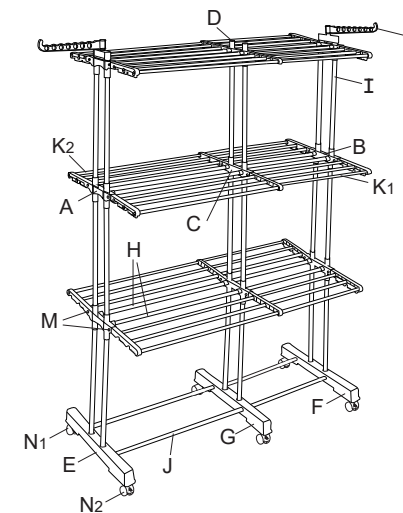

When using, be sure to keep the loading on both sides at the same time

### STEP 1

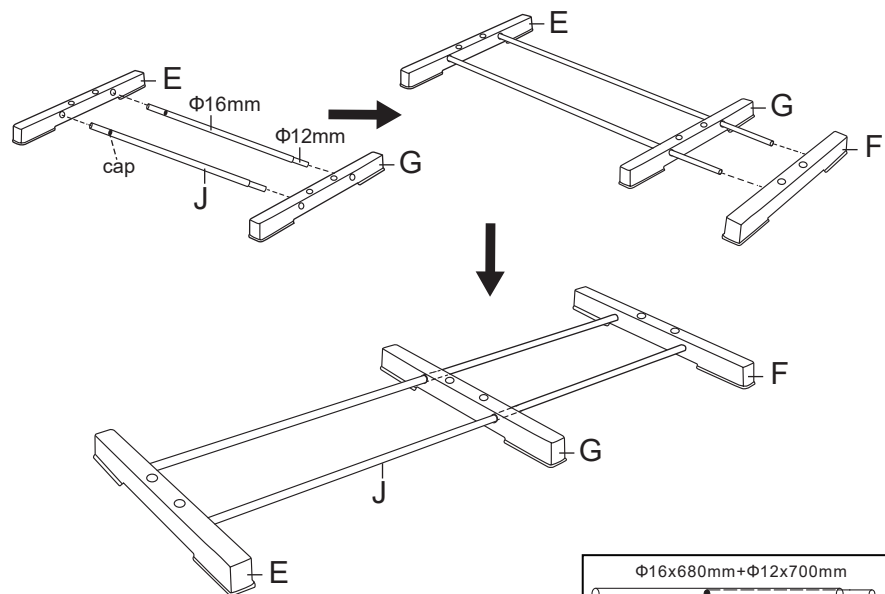

### STEP 2

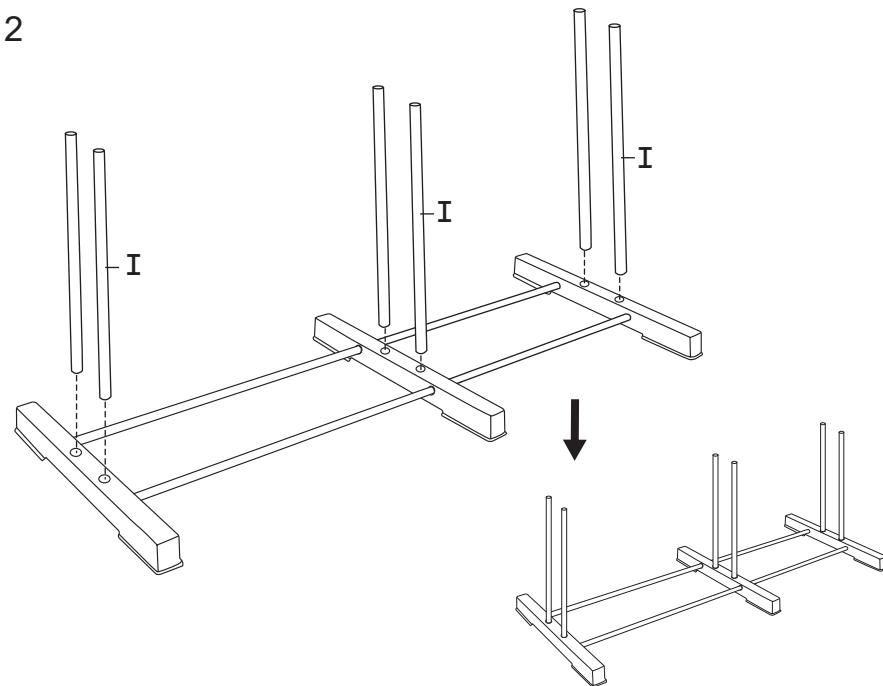

### STEP 3

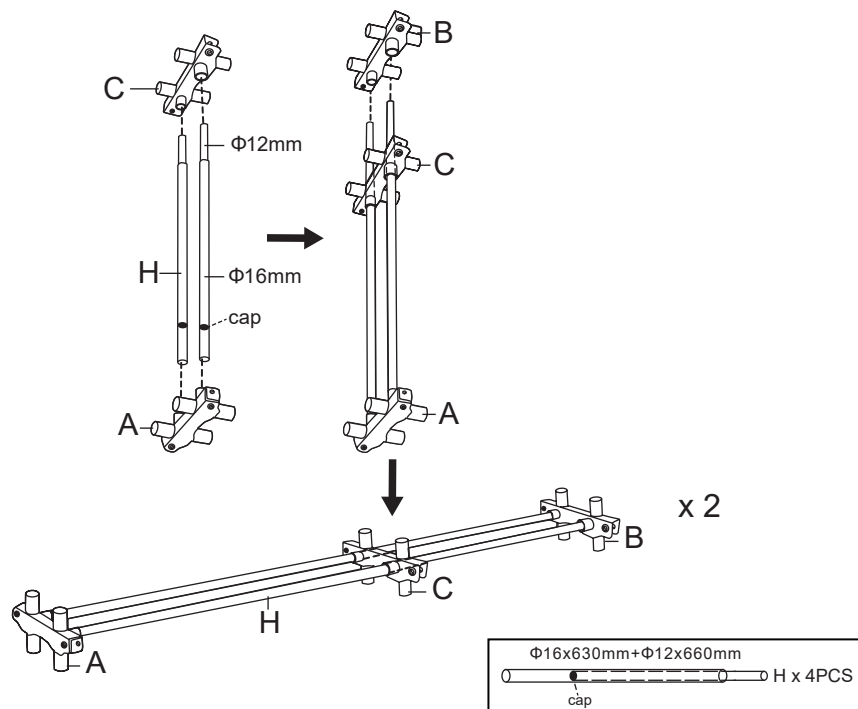

### STEP 4

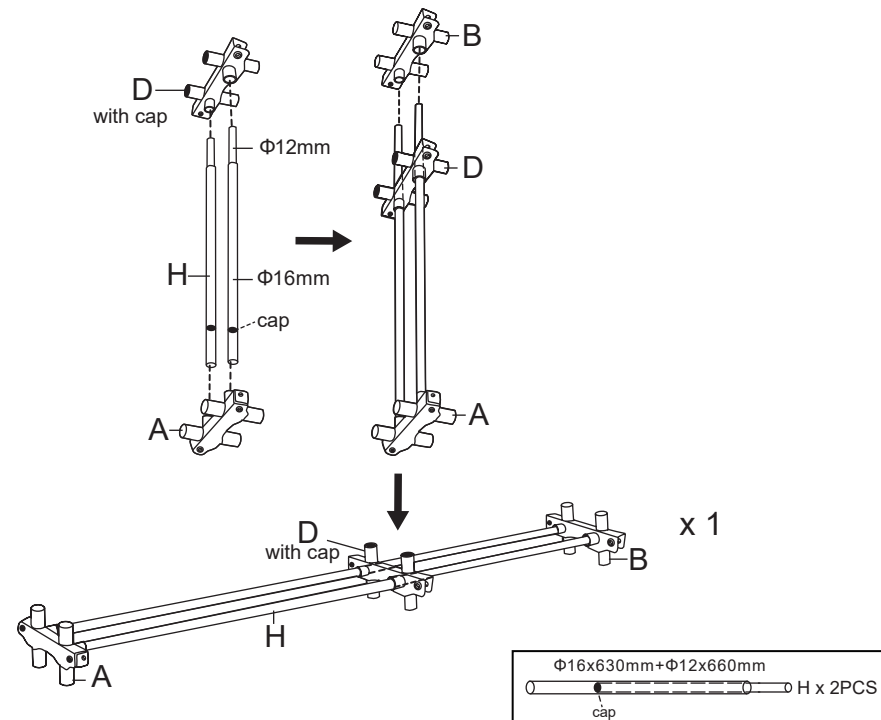

STEP 5

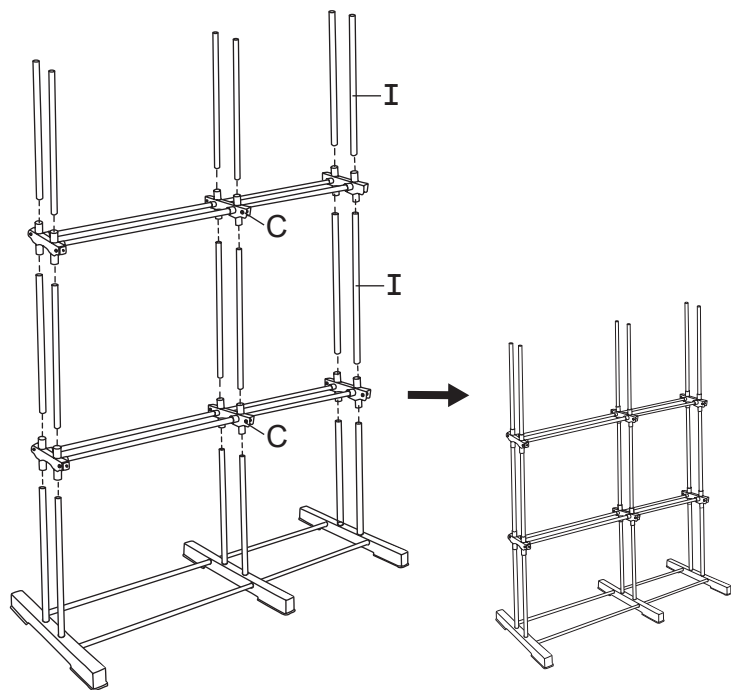

STEP 6

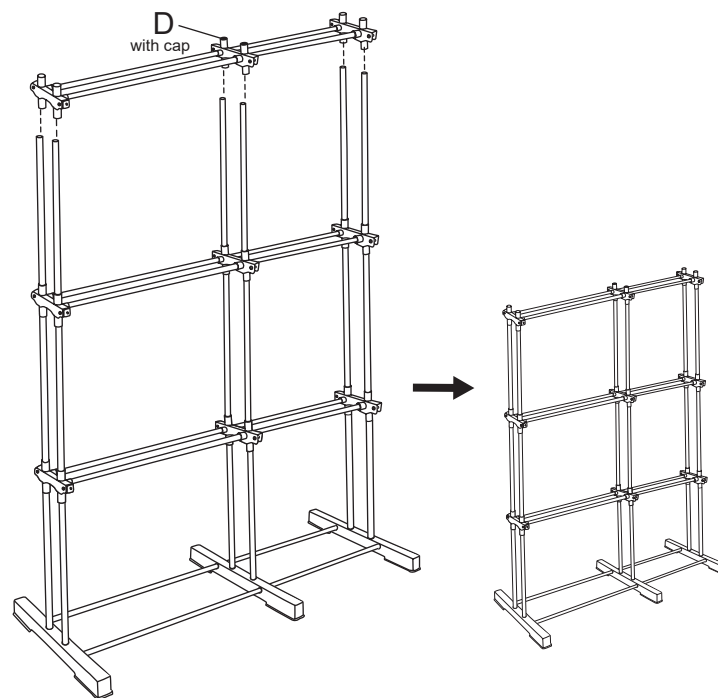

STEP 7

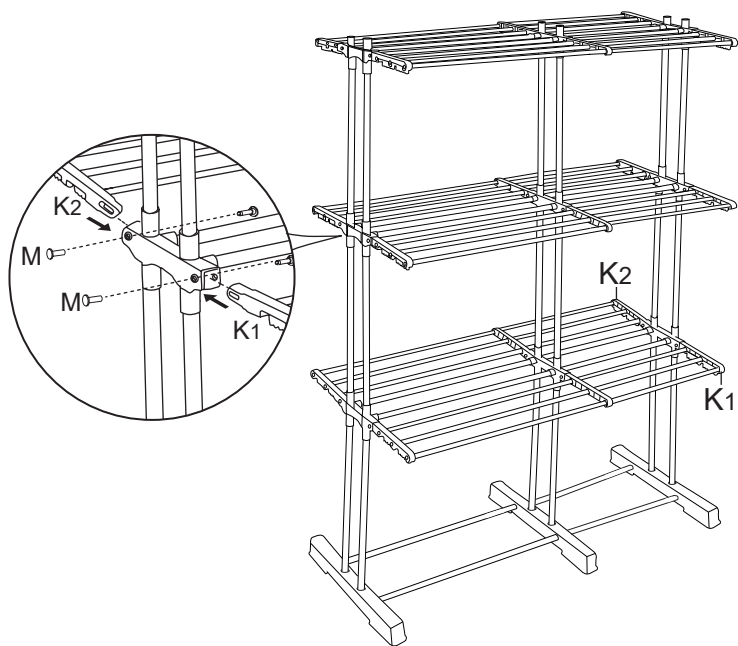

STEP 8

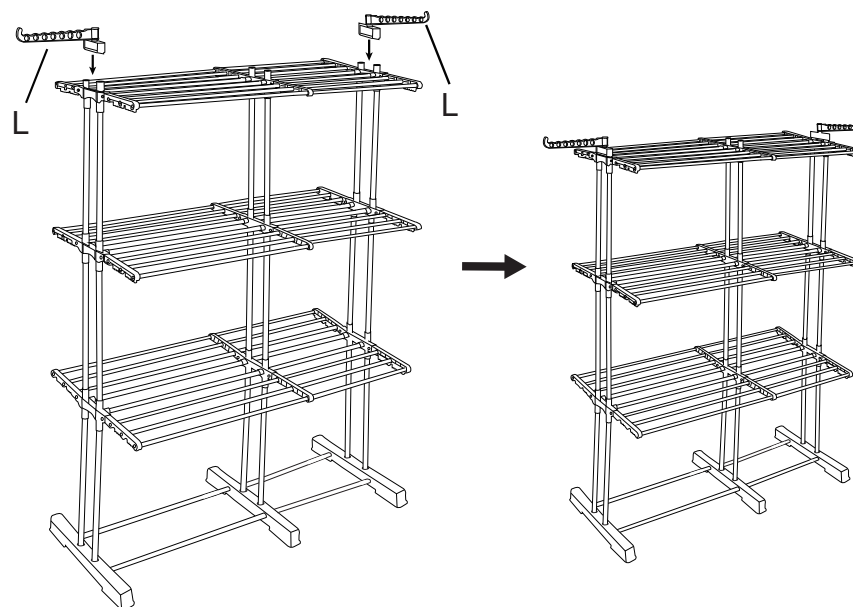

 M x 18PCS

STEP 9

