

Assembly Instructions









K :43479474 | T:70221145 7 DRAWER CHEST





ATTENTION:

DO NOT TIGHTEN THE SCREWS UNTIL THE PRODUCT IS FULLY ASSEMBLED.
FOR INDOOR USE ONLY.

MAXIMUM TOTAL LOADING WEIGHT: 23KG. 10KG FOR THE TOP SHELF, 3KG FOR EACH LARGE DRAWER AND 1.5KG FOR EACH SMALL DRAWER.

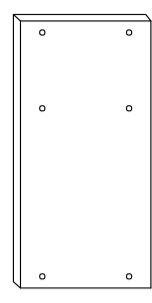
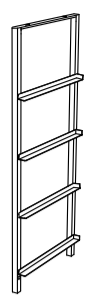
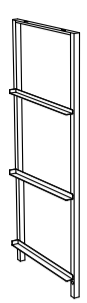
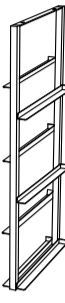
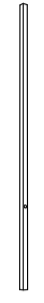
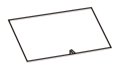
Hardware list

	(A)	4PCS		(E)	2PCS
	(B)	6 PCS		(F)	2PCS
	(C)	6 PCS		(G)	2PCS
	(D)	1PC		(H)	2PCS

	1PC		1PC		1PC
	1PC		2PCS		3PCS
					3PCS
					4PCS
					4PCS

STEP 1

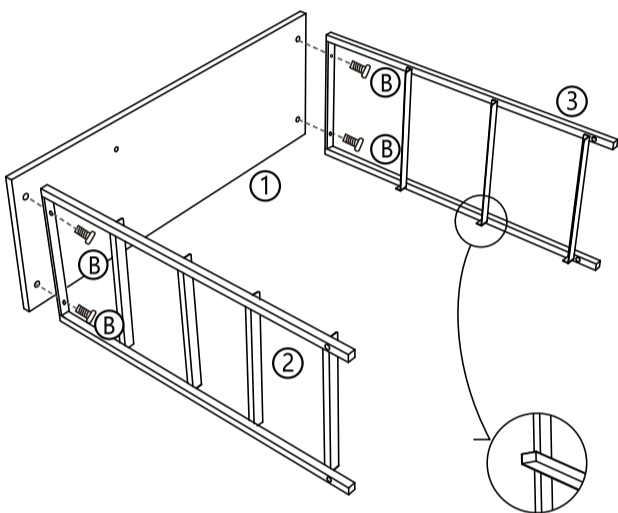

(B) 4pcs

STEP 2

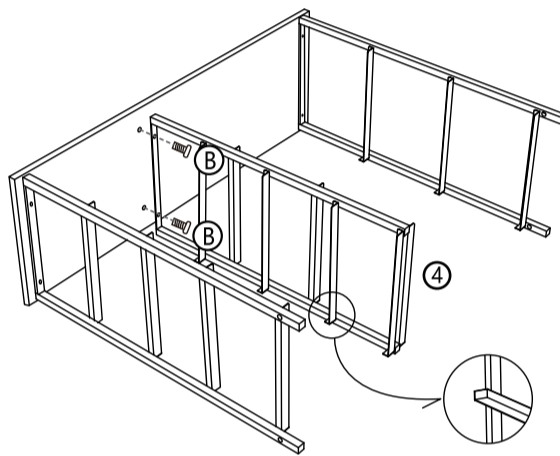

(B) 2pcs

STEP 3

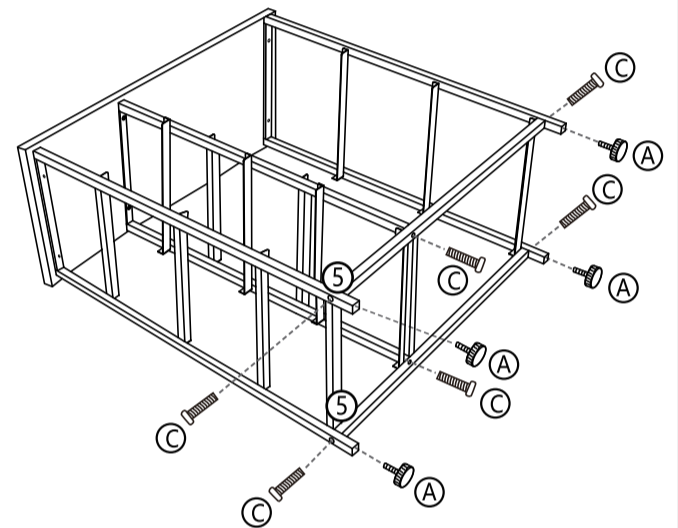

(A) 4pcs (C) 6pcs

STEP 4

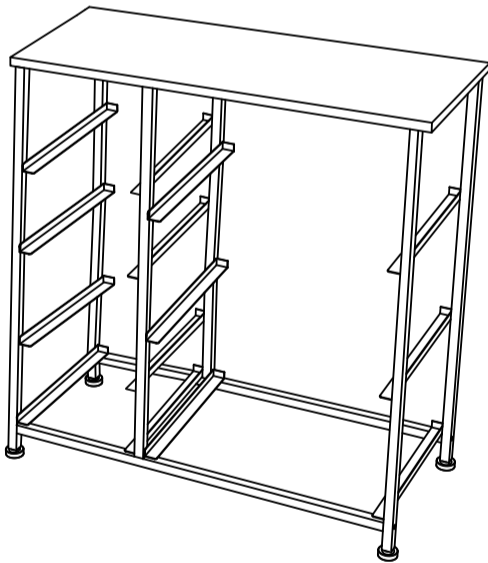

STEP 5

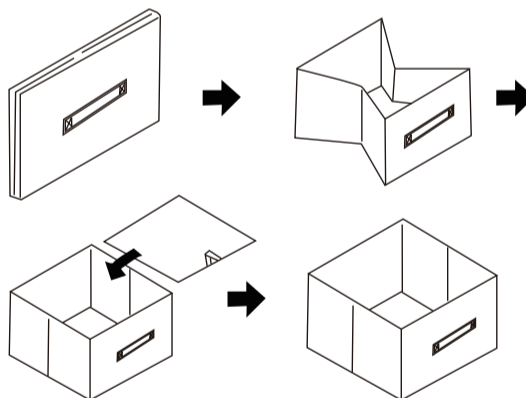

(6) 3pcs (7) 3pcs (8) 4pcs (9) 4pcs

STEP 6

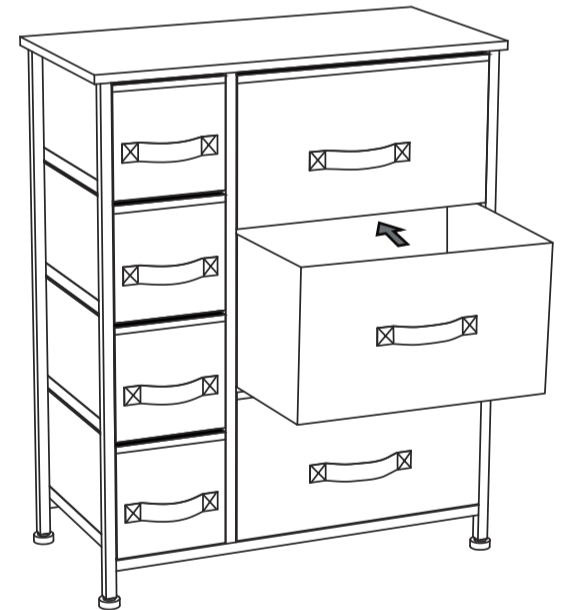

STEP 7

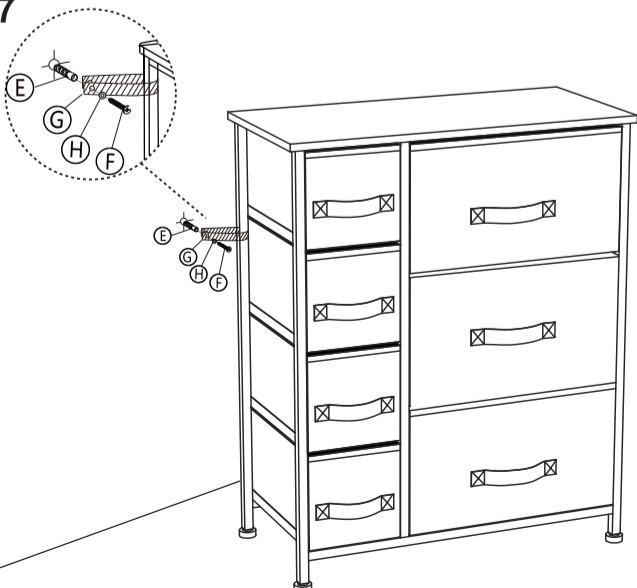

(E) 2pcs (F) 2pcs (G) 2pcs (H) 2pcs

WARNING

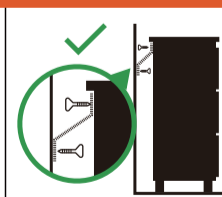

Children have died from furniture tipover.

- ALWAYS secure it with an anchor device.
- NEVER allow children to stand, climb or hang on drawers, doors, or shelves.
- NEVER open more than one drawer at a time.
- Place heavy items down low.

NEVER put a TV on this furniture



This furniture is at high risk of toppling over

Ask staff for more information or visit <https://www.productsafety.gov.au>

Instruction manual should also state:

- It is strongly recommended that this product is permanently fixed to the wall.
- Please seek professional advice if you are in doubt of what fixing device to use.
- Regularly check that anchors are securely maintained.
- Use safety drawer locks to prevent children climbing.
- Stability of tall items may be affected by thick pile carpet or uneven floors.
- Do not place unanchored televisions on furniture.

Caution: for your safety when attaching the anchor fixings, please note the following:

Check any electrical wires or plumbing inside the wall before drilling any holes (if you are unsure please seek professional advice from a qualified tradesperson)



WARNING: PLEASE SECURE YOUR FURNITURE WITH THE SUPPLIED WALL FIXING. SCAN THE CODE FOR MORE INFORMATION.

