

READ AND SAVE IMPORTANT SAFETY INSTRUCTIONS

MIRRORBAL PLUG IN DIFFUSER W/FRAG OIL

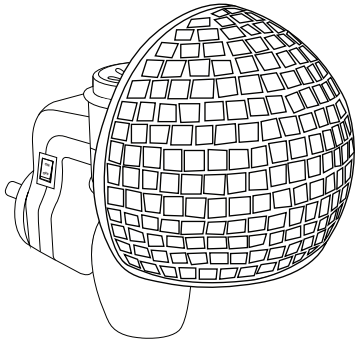

Model B-0509-0A
K: 43482207
T: 70226324

IMPORTANT!

Care should be taken with the use of diffusers around animals. Do not use in small, confined pet areas without adequate ventilation.

FOR FRAGRANCE OIL: KEEP OUT OF REACH OF CHILDREN. NOT TO BE TAKEN.

WARNING- TO REDUCE THE RISK OF BURNS, FIRE, ELECTRIC SHOCK, OR INJURY TO PERSONS:

For fragrance oil replacement, please refer to the "GETTING STARTED INSTALLATION INSTRUCTIONS" section.

For cleaning and descaling, please refer to the "CARE AND MAINTENANCE" section.

- DO NOT** touch the air inlet with a finger, do not block up the air inlet on the top of the diffuser.
- DO NOT** use the diffuser on flammable surfaces or near flammable materials, heat sources or open flames.
- DO NOT** use if the plug-in or diffuser is damaged. If the diffuser malfunctions, is damaged or is immersed in water, stop using the diffuser.

- DO NOT** use other fragrance oils with this electric diffuser. Change or renew the scent with anko fragrance oil only.
- Indoor dry location use only.
- This appliance is not intended for use by persons (including children) with reduced physical, sensory or mental capabilities, or lack of experience and knowledge, unless they have been given supervision or instruction concerning use of the appliance by a person responsible for their safety.
- Children should be supervised to ensure that they do not play with the appliance.
- DO NOT** immerse the diffuser in water or any other liquid.
- DO NOT** leave the diffuser on or unattended overnight. Please press "OFF" to turn off the diffuser & light when not use.
- Unplug the appliance during replacing fragrance oil bottle and cleaning.
- The appliance is only to be used with the recommended vaporizing medium. The use of other substances may give rise to a toxic or fire risk.
- The fragrance oil and wick in the plug-in diffuser may turn yellow during usage. This is a normal phenomenon, the product is still usable.

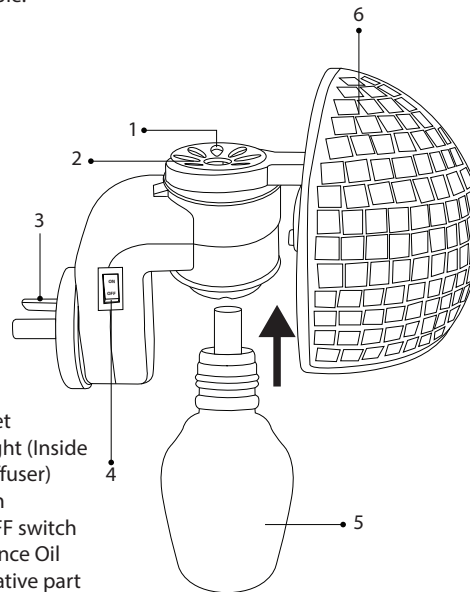

- Air inlet
- LED light (Inside the diffuser)
- Plug-in
- ON/OFF switch
- Fragrance Oil
- Decorative part

GETTING STARTED INSTALLATION INSTRUCTIONS

- For first time use, remove packaging from the electric diffuser & fragrance oil and set on level surface.
- Hold the fragrance oil bottle upright. Twist cap counterclockwise to open. The wick and wick protector will be revealed. Do not remove or touch the wick and wick protector.
- Keeping the wick upright, firmly grip the top of the diffuser unit and insert the fragrance bottle into the bottom of diffuser. Push up until the neck of the bottle clicks all the way into the body of the diffuser.



STEP.1

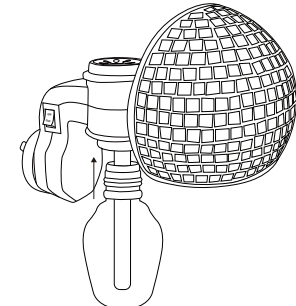

STEP.2

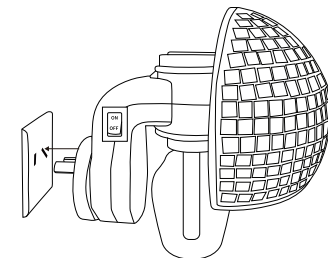

STEP.3

14.5cm(L)X18.5cm(H)

Allow 50cm of space around the product for air flow and diffusion. Do not position in confined spaces or pet areas without adequate ventilation. Do not place oil bottle or cap on finished surfaces as fragrance oil residue may cause damage.

Use only in areas with at least 50cm clearance above the product to avoid potential discoloration to surrounding surfaces.

OPERATING INSTRUCTIONS

1. **Plug product into wall outlet, always keep product upright.** Never allow the fragrance oil bottle to remain in a horizontal position as the fragrance oil will spill. If fragrance oil spills, wipe up immediately as oil may cause damage (discoloration or staining) to finished surfaces.
2. Press "ON" button on the side of product to turn on the diffuser and light function, Press "OFF" to turn off the diffuser and light function.
3. When fragrance bottle is empty, Press "OFF" to turn off the diffuser function, unplug the product from outlet by grasping the side edges. Avoid reaching behind unit to remove from outlet. Allow unit to cool before replacing with new fragrance oil bottle. Firmly hold the top of the diffuser unit and pull the empty fragrance oil bottle downwards with a slight twisting motion. Discard the empty fragrance oil bottle.
4. Note: Never attempt to refill an empty fragrance bottle.

CARE AND MAINTENANCE

1. Always turn OFF and unplug the diffuser for care and maintenance.
2. With use, fragrance oil may collect on the diffuser. To clean, unplug the diffuser and wipe with a dry cloth. No service required.

MOVING AND STORAGE INSTRUCTIONS:

Store used fragrance oils upright to prevent spilling. When storing the electric fragrance diffuser, first allow to cool. Then place the diffuser on top of a cleaning rag or napkin to absorb any potential fragrance oil residue.

12 Month Warranty

Thank you for your purchase.

Your new product is warrantied to be free from defects in materials and workmanship for the period stated above, from the date of purchase, provided that the product is used in accordance with accompanying recommendations or instructions where provided. This warranty is in addition to your rights under the Australian Consumer Law.

For New Zealand customers, this warranty is in addition to statutory rights observed under New Zealand legislation.

We will provide you with your choice of a refund, repair (where possible) or exchange (availability dependent) for this product if it becomes defective within the warranty period. The business will bear the reasonable expense of claiming the warranty.

This warranty will no longer apply where the defect is a result of alteration, accident, misuse, abuse or neglect.

Please retain your receipt as proof of purchase and contact our Customer Service Centre as listed below, for the entity you purchased this product from, for any difficulties with your product. Warranty claims and claims for expense incurred in returning this product can be addressed to the respective Customer Service Centre.

Our goods come with guarantees that cannot be excluded under the Australian Consumer Law. You are entitled to a replacement or refund for a major failure and compensation for any other reasonably foreseeable loss or damage.

You are also entitled to have the goods repaired or replaced if the goods fail to be of acceptable quality and the failure does not amount to a major failure.

WARNING: When using this electric product, please follow all basic precautions including the following: Read all instructions carefully before using this product. To reduce the risk of injury, close supervision is necessary when the product is used near children and pets. Do not put fingers or hands into the product. Do not immerse in water. Risk of electrical shock. This product is not a toy. For adult use only.

FIRST AID INSTRUCTION: For advice, contact a Poisons Information Centre (e.g. phone Australia 131126; New Zealand (0800 764 766) or a doctor at once. If swallowed, do NOT induce vomiting. Keep away from children.

Contact for Kmart purchases

Kmart Australia Ltd.
C/- Customer Service Centre 690 Springvale Road, Mulgrave Vic 3170
Customer Service: 1800 124 125 (Australia) or 0800 945 995 (New Zealand) or via Customer Help at kmart.com.au

Contact for Target purchases

Target Australia Pty Ltd
C/- Customer Service Centre
2 Kendall Street, Williams Landing, Vic, 3027
Customer Service: 1300 753 567 or via Customer Help at target.com.au/help/contact-us