

# Assembly Instructions

## 43484263 TEXTURED ARCHED BOOKCASE











**CARE INSTRUCTION:** Wipe clean with a soft dry or damp cloth. Keep away from water and direct sunlight. For indoor and domestic use. Check and tighten all parts regularly.

Please lay furniture on the carpet to avoid any dirty or damage on texture during assembly.

**WARNINGS:** Do not stand or sit on the unit. Do not lean on the product. Do not drag the product. Use only on a flat surface. Do not use until all screws, bolts and knobs are firmly secured. This product contains small parts and sharp points, keep away from children and babies. Adult assembly required. Failure to follow these warnings could result in serious injury.

**MAXIMUM TOTAL LOADING WEIGHT:** 10KGS FOR EACH SHELF, 40KGS IN TOTAL.

### Hardware list

	a		26PCS		g	3X14mm	6PCS
	b		26PCS		h	4X12mm	1PC
	c	6X30mm	24PCS		i		1PC
	d	4X30mm	4PCS		j	4X30mm	1PC
	e		4PCS		k		1PC
	f		6PCS				

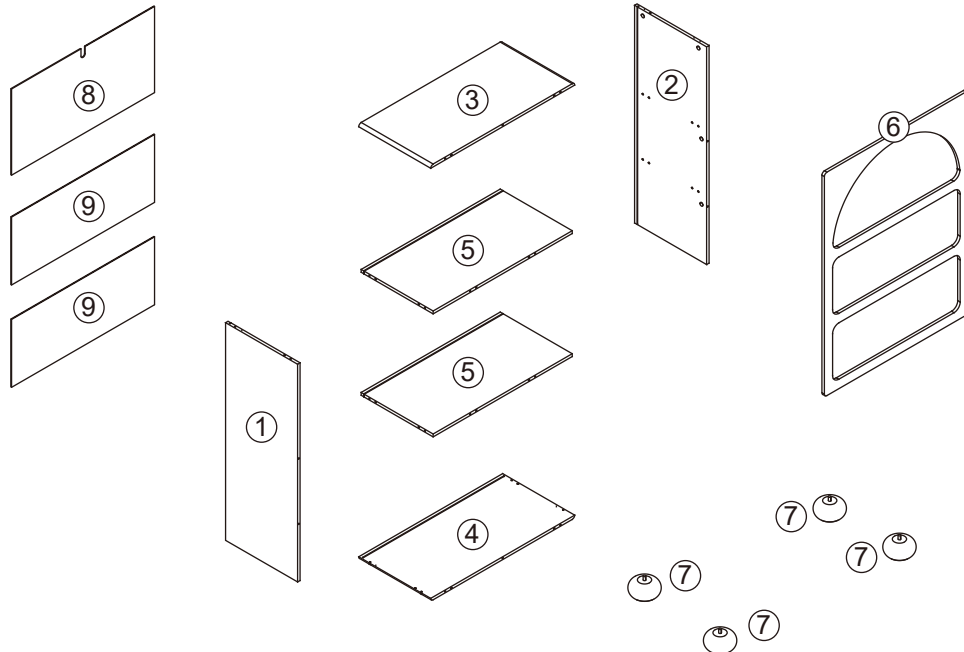

**DO NOT TIGHTEN THE SCREWS UNTIL THE PRODUCT IS FULLY ASSEMBLED.**

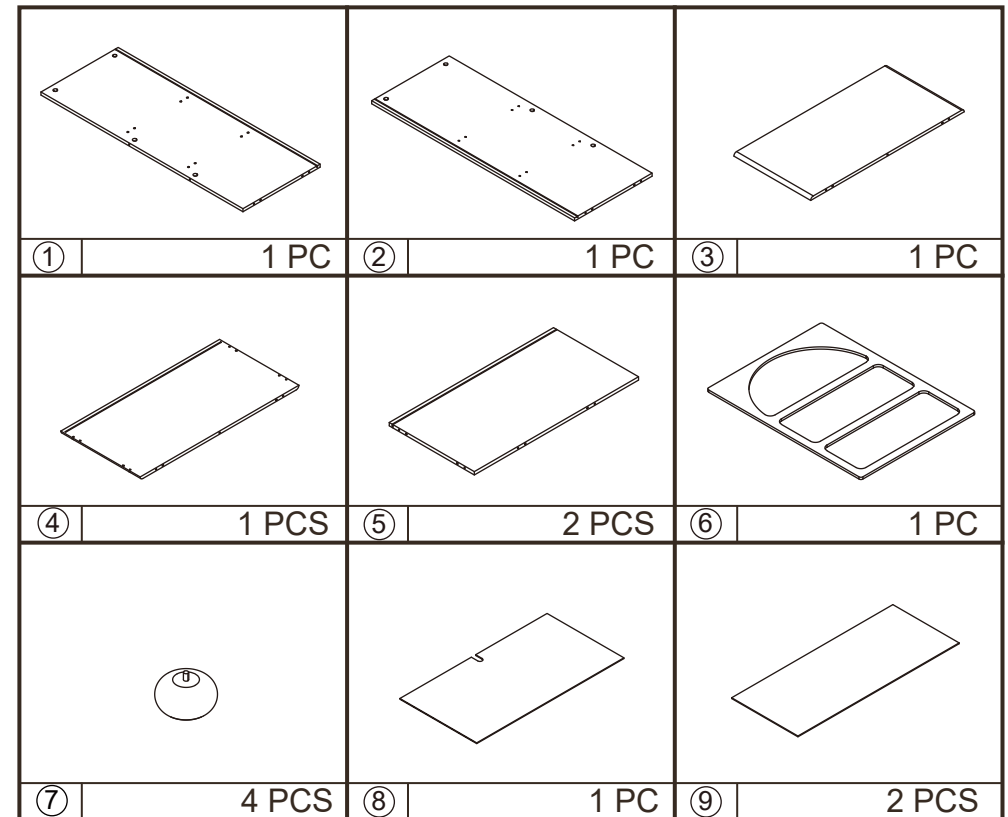

### STEP 1

 X4  X4

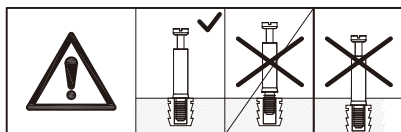
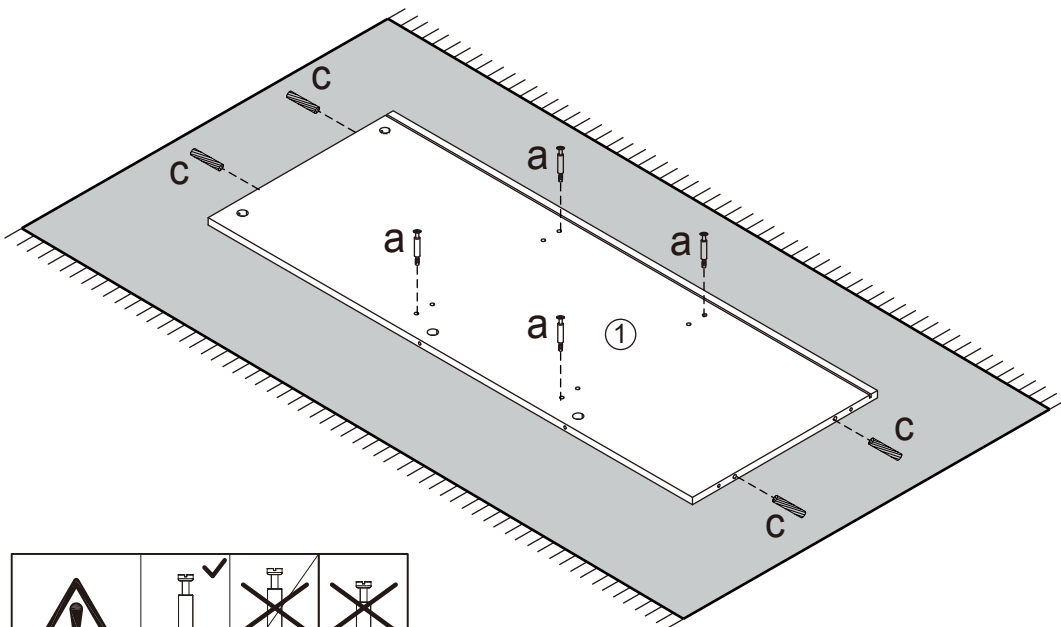

### STEP 2

 X8

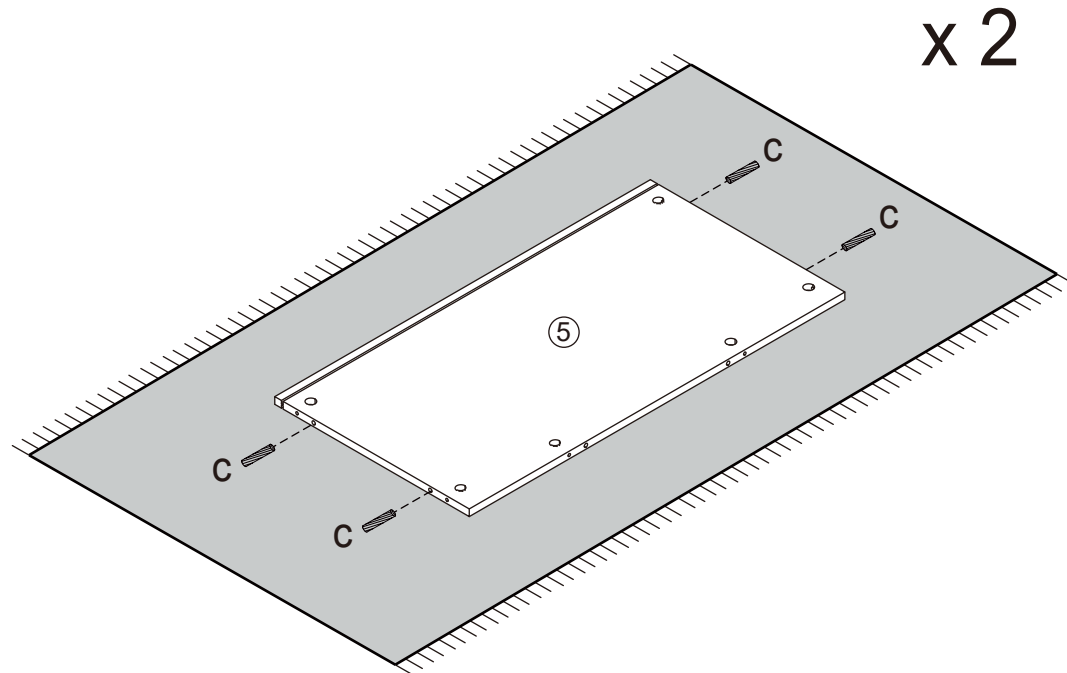

### STEP 3

 X4

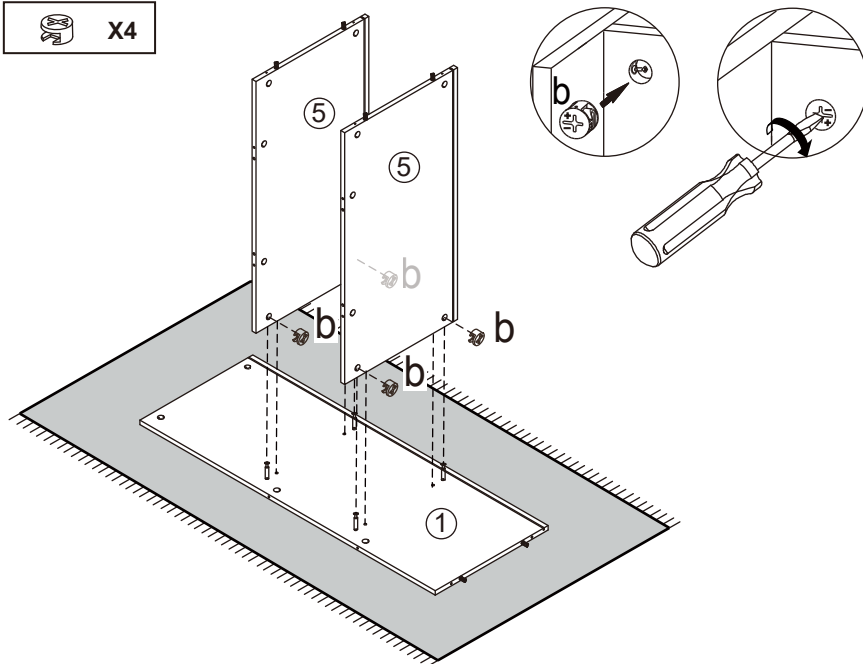

### STEP 4

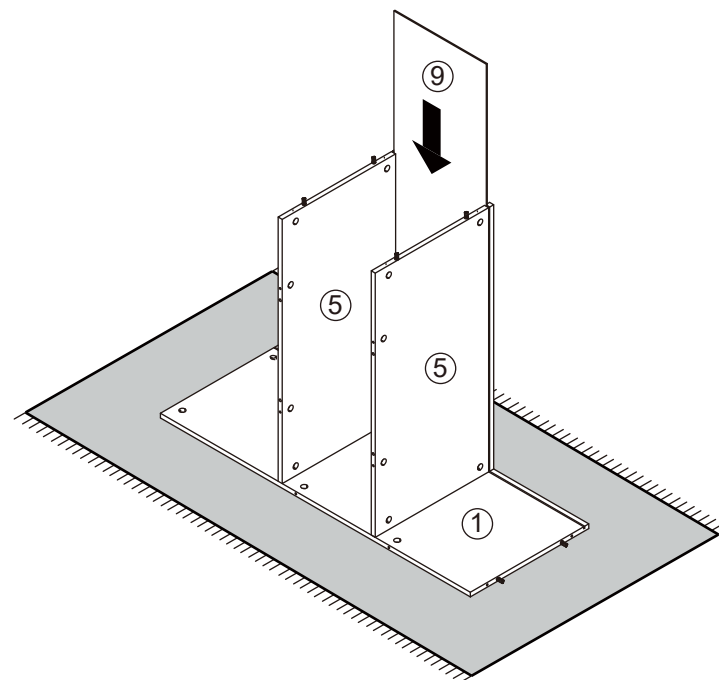

**STEP 5**

 X4  X4

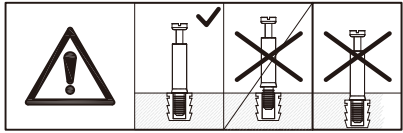
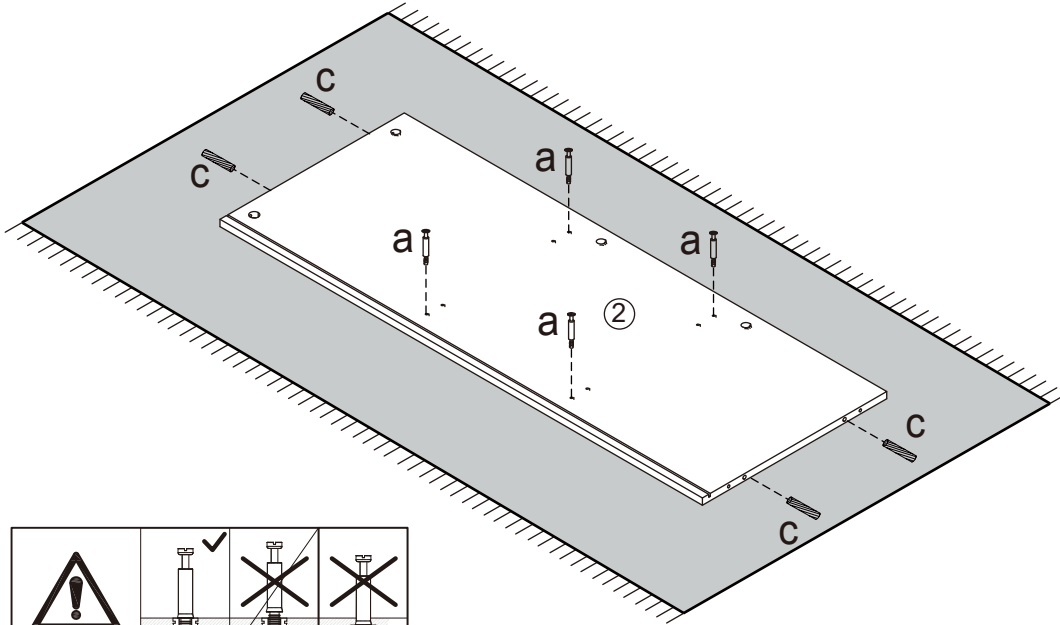

**STEP 6**

 X4

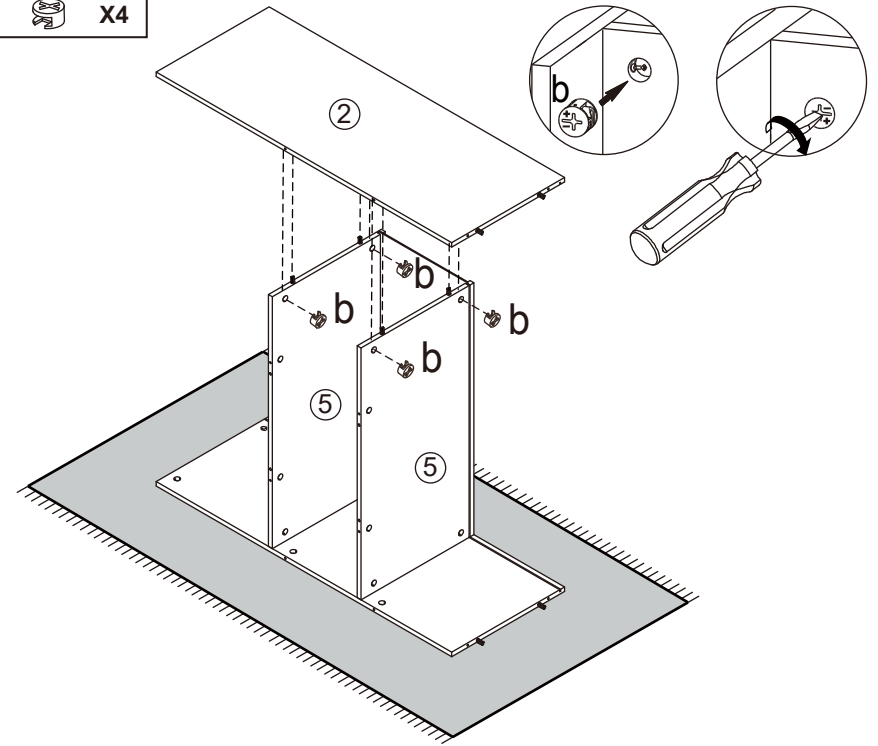

**STEP 7**

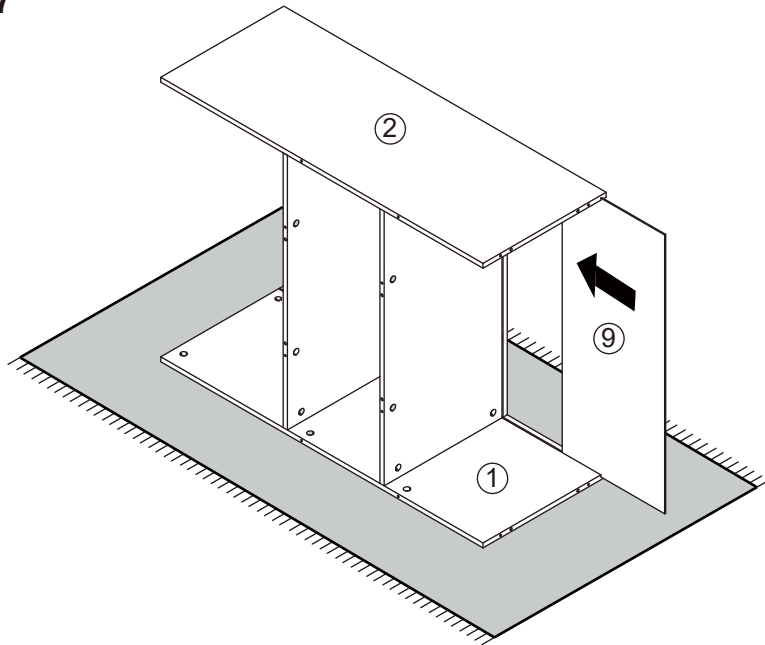

**STEP 8**

 X4

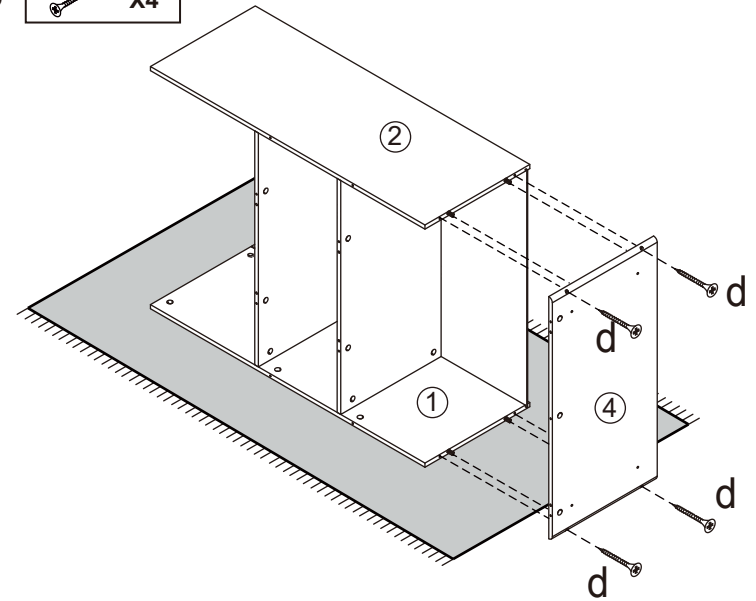

### STEP 9

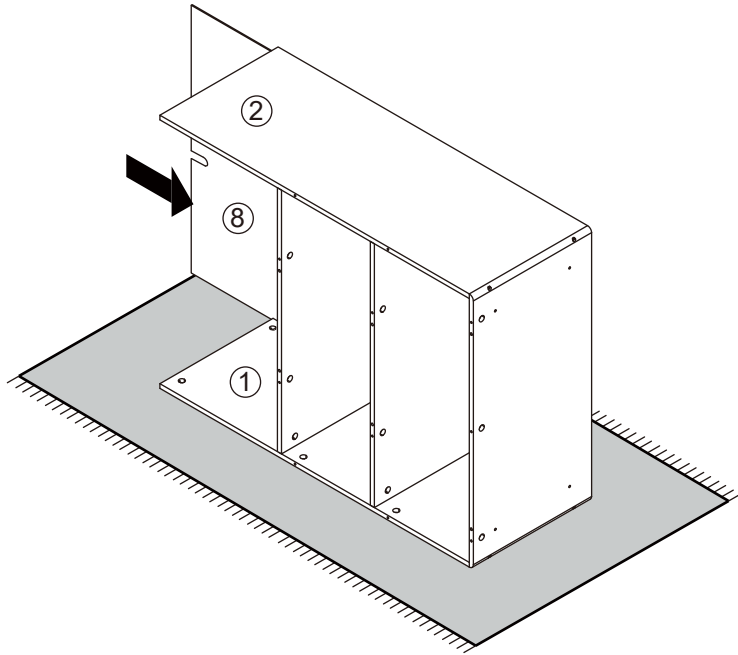

### STEP 10

 X4    X1    X1

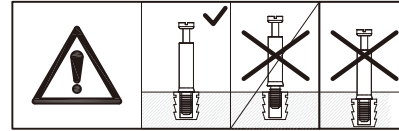
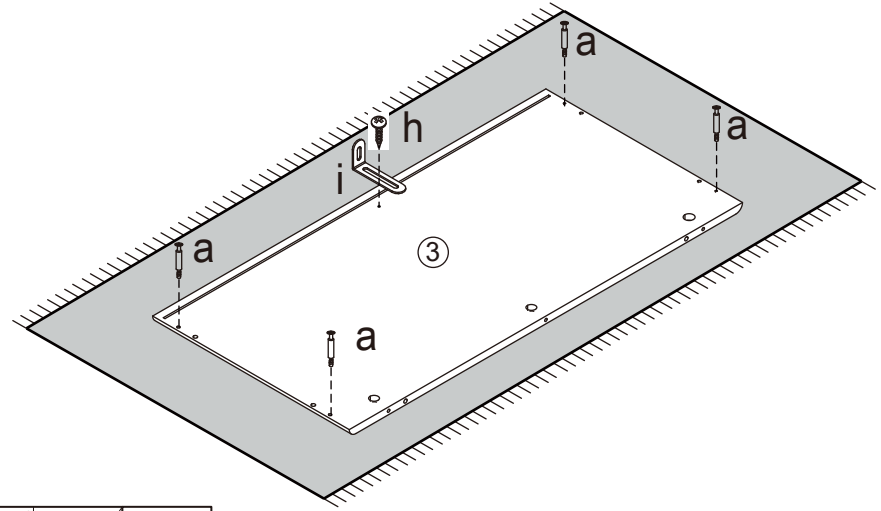
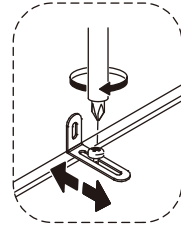
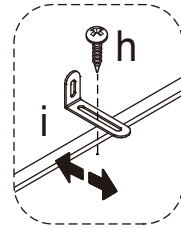

### STEP 11

 X4

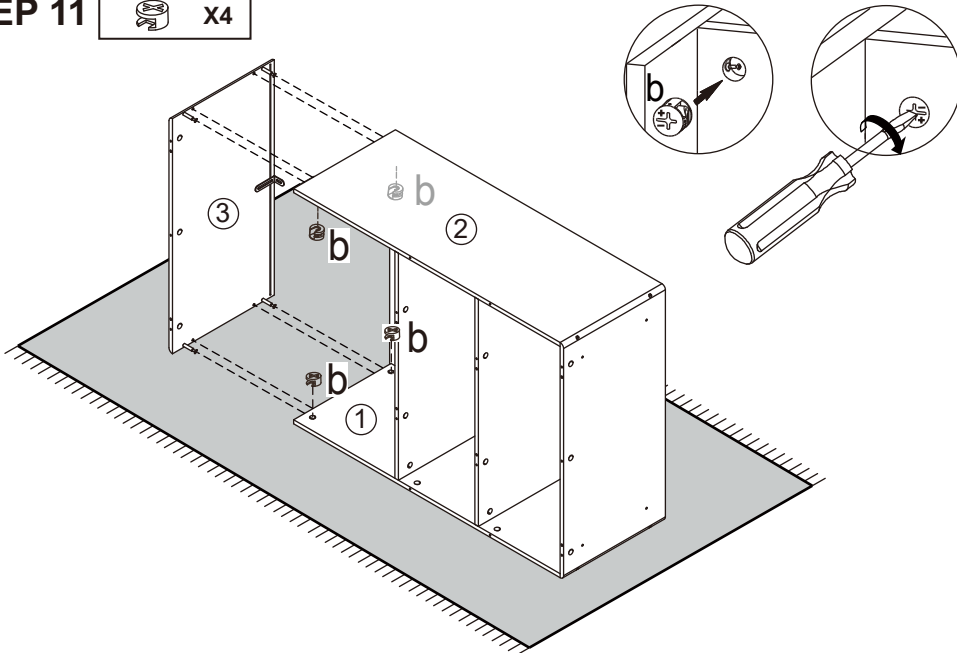

### STEP 12

 X8

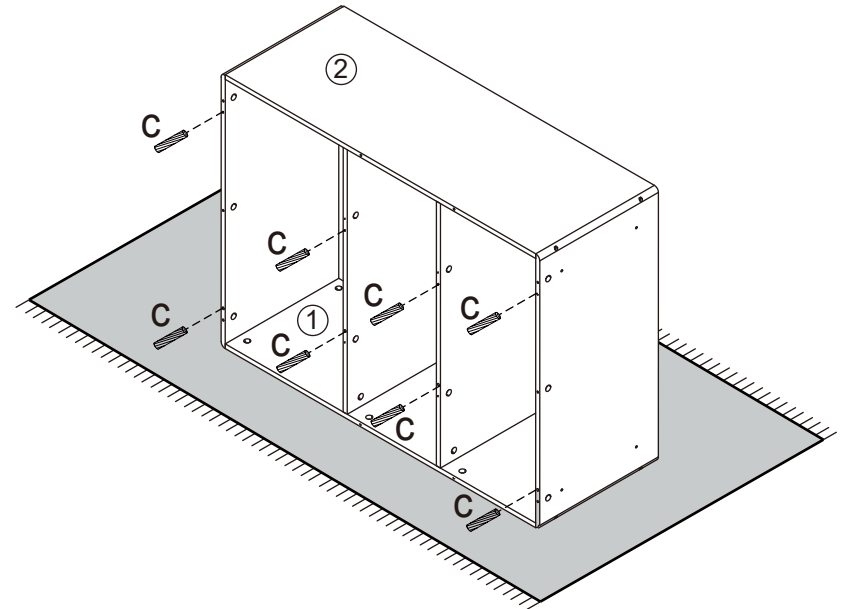

**STEP 13**  X14

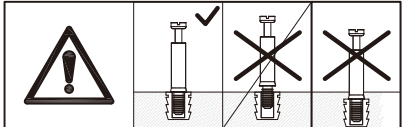
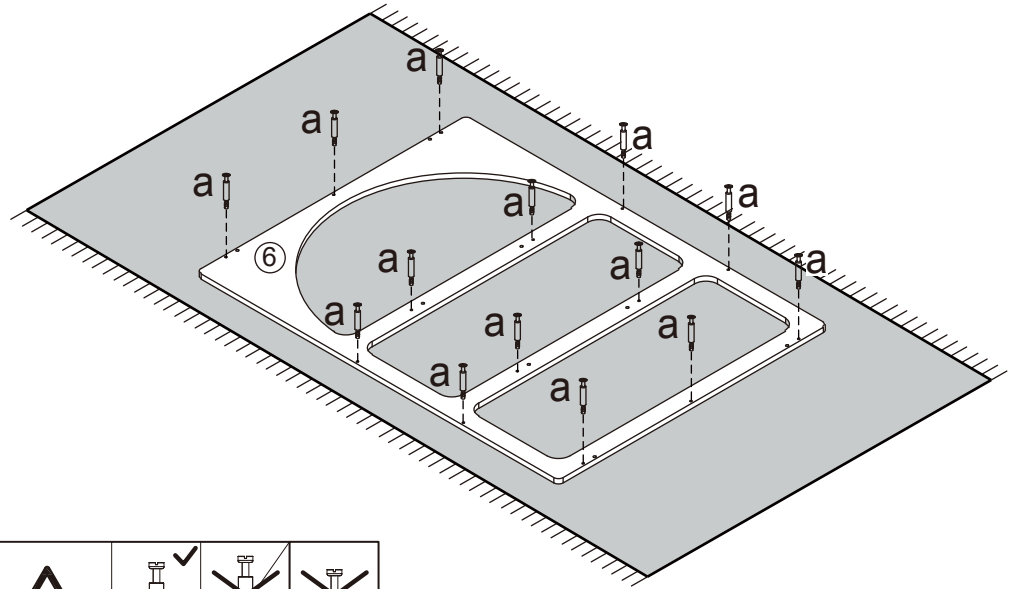

**STEP 14**  X14

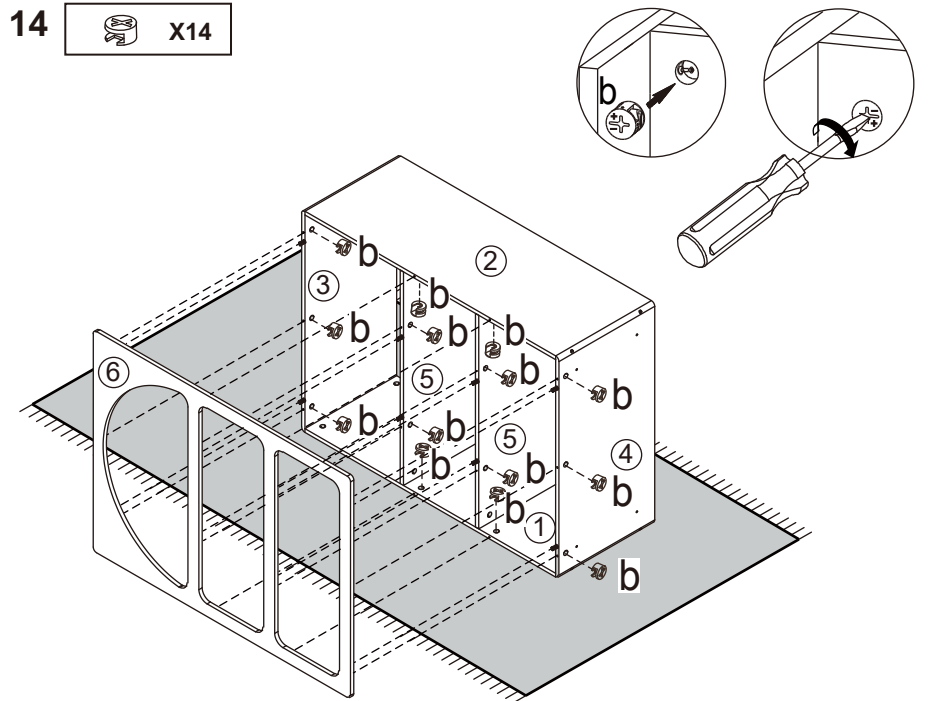

**STEP 15**

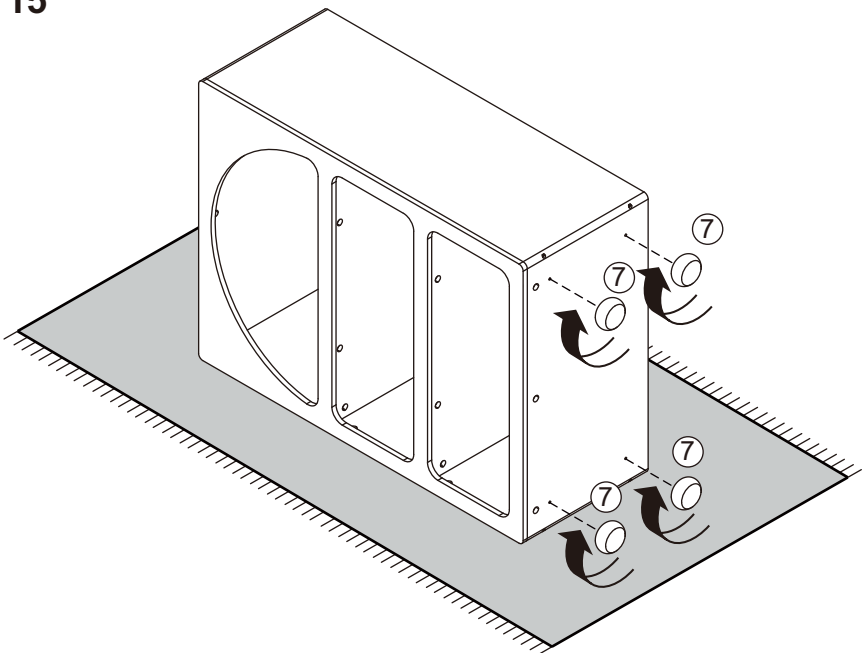

**STEP 16**  X4

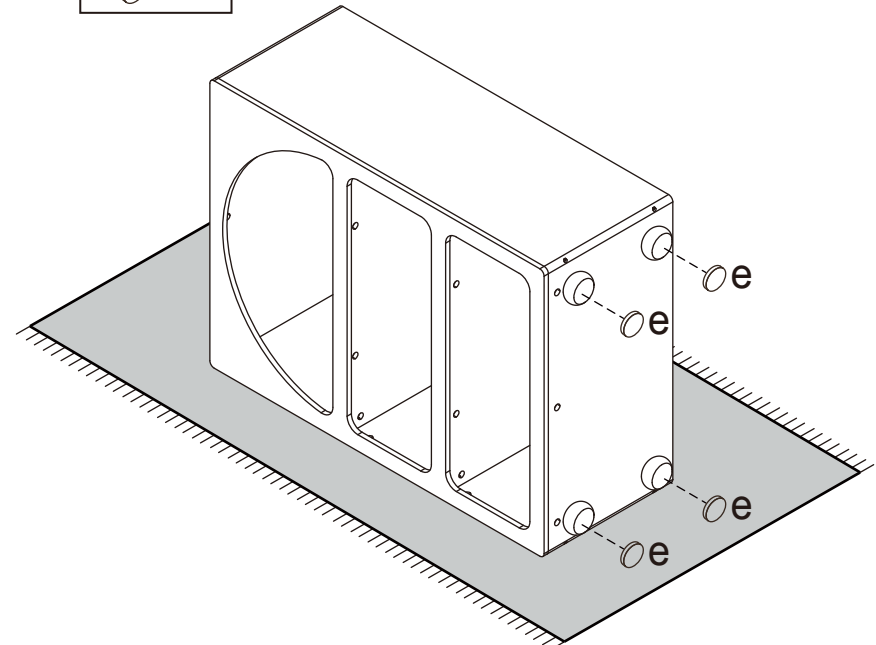

# STEP 17

 X6

 X6

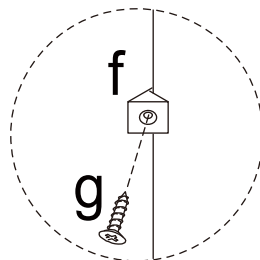
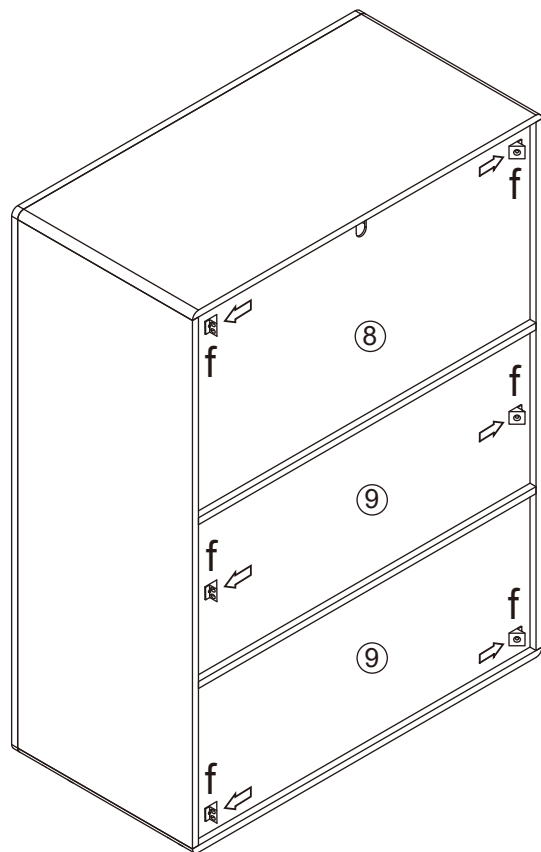

# STEP 18

 X1

 X1

### Warning:

- It is strongly recommended that this product is permanently fixed to the wall.
- Please seek professional advice if you are in doubt of what fixing device to use.
- Regularly check that anchors are securely maintained.
- Use safety drawer locks to prevent children climbing.
- Stability of tall items may be affected by thick pile carpet or uneven floors.

• Do not place unanchored televisions on furniture.

**Caution:** for your safety when attaching the anchor fixings, please note the following:

- Check any electrical wires or plumbing inside the wall before drilling any holes (if you are unsure please seek professional advice from a qualified tradesperson)



**WARNING: PLEASE SECURE YOUR FURNITURE WITH THE SUPPLIED WALL FIXING. SCAN THE CODE FOR MORE INFORMATION.**

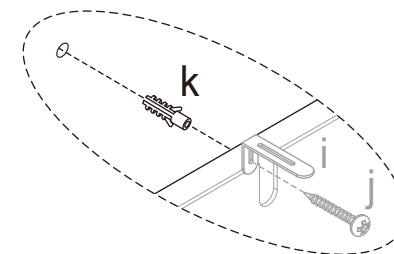

## ⚠ WARNING

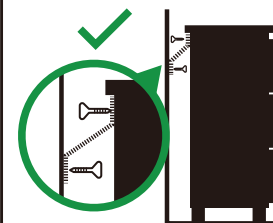

### Children have died from furniture tipover.

- ALWAYS secure it with an anchor device.
- NEVER allow children to stand, climb or hang on drawers, doors, or shelves.
- NEVER open more than one drawer at a time.
- Place heavy items down low.

**NEVER put a TV on this furniture**



**This is a permanent label. Do not remove!**

