

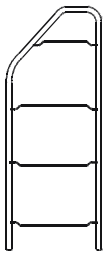

Assembly Instructions

4 Tier Shoe Rack

Parts Supplied

Ref	Description	Illustration	Qty
A/B	Side Stand - Left and Right side		2
C	Plastic End Cap (Prefixed on Side Stand A/B)		4

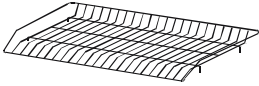
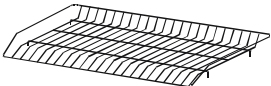
Ref	Description	Illustration	Qty
D	Top Shelf		1
E	Big Shelf		3

- **No tools required.**

Assembly Instructions

1. Check the Plastic End Caps (C) if they are well fixed on the Side Stands (A/B) (see Step 1).
2. While holding the Right Side Stand (A) upright. Hook the prongs of the Top Shelf (D) over the top rung of the Right Side Stand (A). Hook the prongs of the Top Shelf (D) over the top rung of the Left Side Stand (B). Place the remaining Big Shelf (E) on the bottom rungs of the both Side Stand (A/B) (see Step 2).
3. Install the two remaining Big Shelf (E) by holding one end higher than the other, inserting the prongs on the low end over the rungs on the Right Side Stand (A) first, then lowering the opposite end until the prongs lock over the rungs on the Left Side Stand (B) (see Step 3).

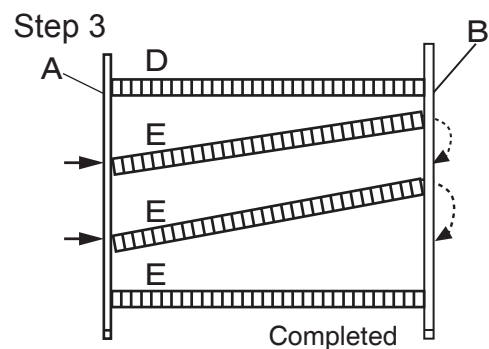
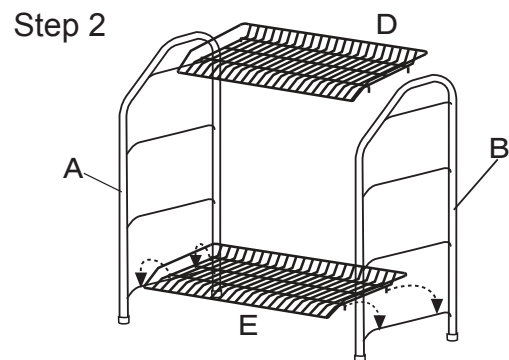
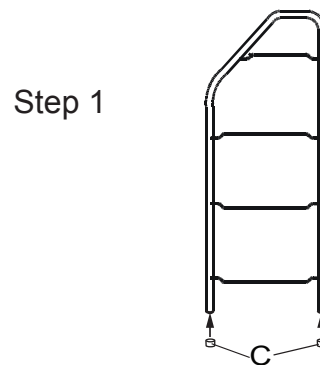

Care & Use

- Wipe clean with a soft damp cloth. Never use scourers, abrasives or chemical cleaners.
- **MAXIMUM WEIGHT LOAD 3KGS** evenly distributed over each tier.