

## SAFETY INFORMATION

### ⚠ WARNING:

- Protective equipment should be worn such as a helmet, gloves, knee-pads and elbow-pads.
- Always wear fully enclosed shoes.
- Do not use scooter at night.
- Do not use on wet surfaces, uneven or unpaved road.
- It is not recommended the scooter be used on steep slopes at high speed.
- Avoid sharp bumps, drainage grates and sudden surface changes.
- This scooter is not designed for off-road use or stunting.
- Never ride with more than one person on the scooter.
- Always follow local traffic laws.
- Always check the brakes before riding.
- Adult assembly required.
- Brake will get hot from continuous use, do not touch after braking.
- Read all information supplied by the manufacturer before riding.
- Recommended for children age 5 and up.
- **NOT FOR CHILDREN WITH A BODY MASS OF MORE THAN 50KGS.**

**FAILURE TO FOLLOW THESE INSTRUCTIONS MAY CAUSE SERIOUS INJURY**

- Check and secure all fasteners before every ride.
- Ensure the clamp is locked correctly into position before every ride.
- **Wheel and Bearings:** Periodically check wheels and bearings for wear and tear and correct axle tightness.
- Replace worn and broken parts immediately.

Thanks for your purchase this product. If any parts are missing or damaged, please contact one of our Customer Service Representatives by phone on

**1800-632-792 ( Australia)**

**0800-623-792 (New Zealand)**

**via email at [spares@hunterleisure.com.au](mailto:spares@hunterleisure.com.au)**

**visit [www.momentumservicesco.com](http://www.momentumservicesco.com)**

**Hunter Leisure Pty,Ltd**

94 Keilor Park Drive Tullamarine, 3043, Victoria, Australia

**DO NOT RETURN THIS PRODUCT TO THE STORE!**

## ASSEMBLY INSTRUCTIONS

Loosen the head screw and clamp. Insert the handlebar into the main frame, ensure the handlebars are aligned at right angles with the front wheel.

Tighten clamp and screw securely.

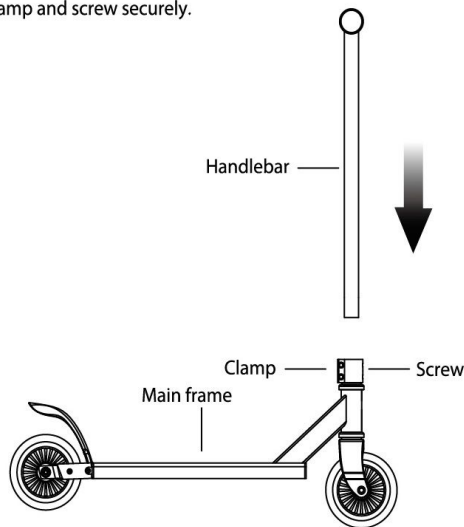

### ⚠ WARNING:

Failure to correctly install and tighten clamp may cause the rider to lose control and fall from the scooter. If you are unsure, please seek assistance by an experienced bicycle mechanic.

**No modifications should be made to the scooter. The supplier will not be liable for any damage or injury that may occur with a modified product.**

**FAILURE TO FOLLOW THESE INSTRUCTIONS MAY CAUSE SERIOUS INJURY.**

ASSEMBLY MUST BE COMPLETED BY AN ADULT. Obtain the required tools and then follow the assembly instructions in this manual. If you do not have the required tools, or have troubles understanding the instructions, we recommend that you seek assistance by an experienced bicycle mechanic.

THIS MANUAL CONTAINS IMPORTANT SAFETY, ASSEMBLY AND MAINTENANCE INFORMATION. Keep this manual for future reference.

### ⚠ WARNING:

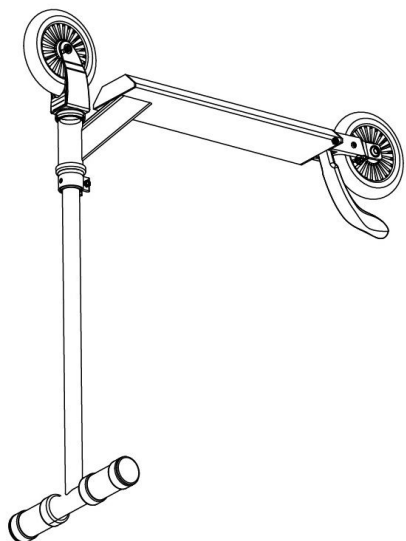

**INLINE SCOOTER  
OWNERS MANUAL & ASSEMBLY INSTRUCTIONS**

## MAINTENANCE

1. Place one foot on the footboard of the scooter and use your other foot to propel the scooter.
2. To stop the scooter, apply the brake by stepping on the rear brake. We recommend that you practice applying the brake at various speeds and in an open area free from obstructions.

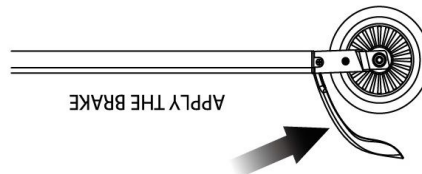

**SCOOTER MAINTENANCE:** Properly maintaining your scooter will provide years of scooter-riding fun. To keep your scooter in good working order, do the following: Every time you ride, check and verify that the scooter is properly set up and locked. After riding, clean your scooter with a dry cloth to remove dirt and grime.

**WEEKLY SERVICE:** (Must be performed by and Adult or under Adult supervision) Apply a few drops of general purpose oil (available at your local hardware store) to the sides of each wheel axle. Verify that the axle screw are tight.

## RIDING YOUR SCOOTER