

ASSEMBLY INSTRUCTIONS - BIANCA DINING CHAIR

CAUTION:

PLEASE READ THESE INSTRUCTIONS CAREFULLY.

1. ENSURE YOU HAVE ALL PARTS BEFORE YOU START ASSEMBLING.
2. ASSEMBLE ON A CLEAN SOFT CARPETED SURFACE TO AVOID SCRATCHING THE SURFACE OF THE CHAIR.
3. WHEN CLEANING THE SURFACE, USE A DAMP CLOTH OR DRY CLEAN CLOTH. DO NOT USE ABRASIVE MATERIALS AND SOLVENTS. KEEP AWAY FROM DIRECT SUNLIGHT. FOR INDOOR USE ONLY.
4. CHECK THE FOOT PADS ON A REGULAR BASIS TO ENSURE THEY ARE IN GOOD CONDITION AND WILL NOT SCRATCH THE FLOOR.
5. CHECK TIGHTNESS OF SCREWS EVERY 4-6 WEEKS.

WARNING:

- DO NOT STAND ON THE CHAIR.
- DO NOT USE THE CHAIR AS A STEP LADDER.
- USE FOR ONE PERSON ONLY.
- DO NOT USE THE CHAIR UNLESS ALL BOLTS, SCREWS AND KNOBS ARE FIRMLY SECURED.
- DO NOT DRAG THE CHAIR ON THE WOODEN FLOOR.
- TAKE CARE IF USING POWER TOOLS TO ASSEMBLE THE PRODUCT.

FAILURE TO FOLLOW THESE WARNINGS COULD RESULT IN SERIOUS INJURY.

THIS PACKAGE CONTAINS SMALL PARTS AND SHARP POINTS.

KEEP AWAY FROM CHILDREN AND BABIES UNTIL ASSEMBLY IS COMPLETE. ADULT ASSEMBLY REQUIRED.

MAXIMUM SAFE LOAD: 100KGS.

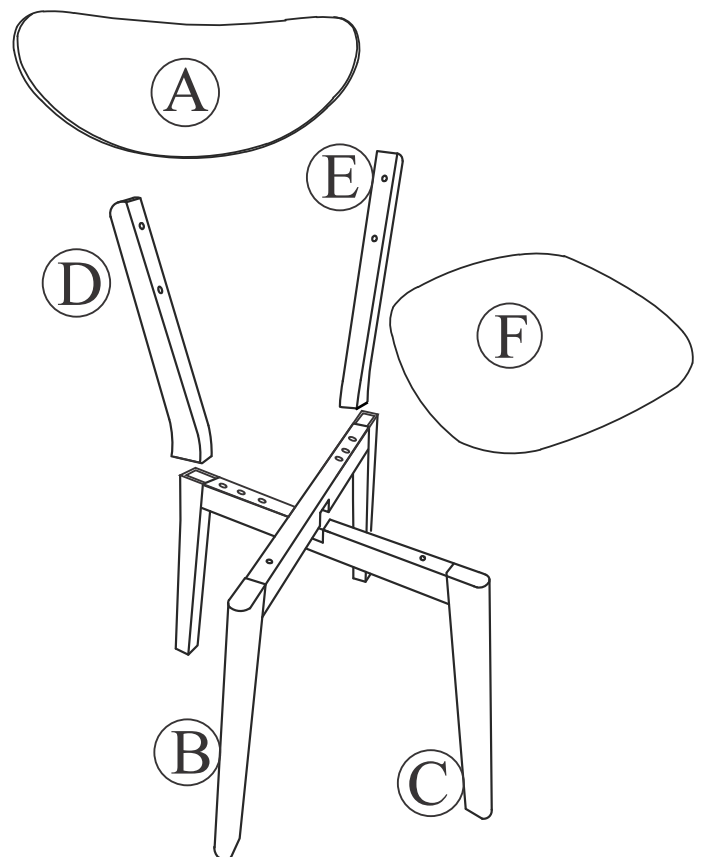
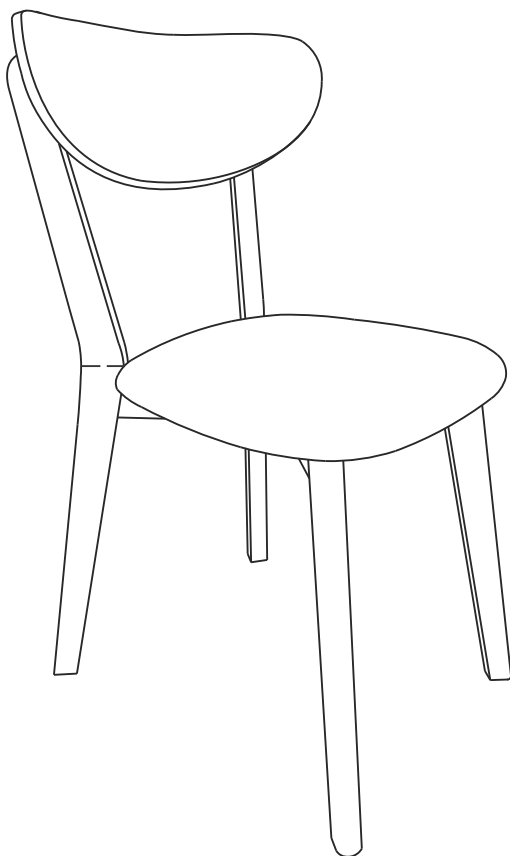

G x4



ST6x35mm

H x8



M6x30mm

I x4



M6x60mm

J x1



80x25mm

K x4



M6(outer dia18x1mm)

L x2

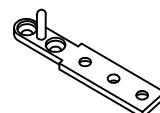

M6(outer dia11x2mm)

M x4



1

Step 1. Using the hex key (PART J), join the piece (PART L) into (PART E) with the screws (PART H).

Step 2. Align (PART E) and (PART B) as per below diagram.

Step 3. Using the hex key (PART J), join the pieces together loosely with the screws (PART G).

Step 4. Tighten the screw closest to the chair leg first. Adjust PART E so that pieces are aligned before tightening the second screw.

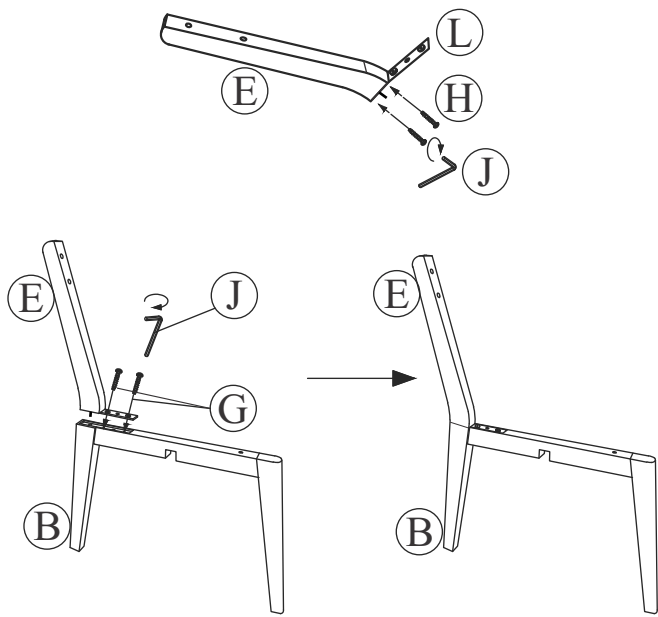
**2**

Step 1. Using the hex key (PART J), join the piece (PART L) into (PART D) with the screws (PART H).

Step 2. Align (PART D) and (PART C) as per below diagram.

Step 3. Using the hex key (PART J), join the pieces together loosely with the screws (PART G).

Step 4. Tighten the screw closest to the chair leg first. Adjust PART D so that pieces are aligned before tightening the second screw.

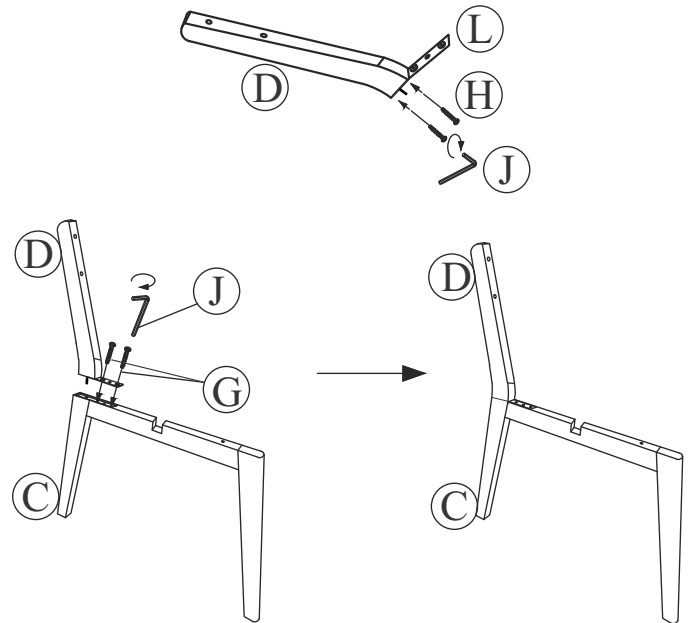
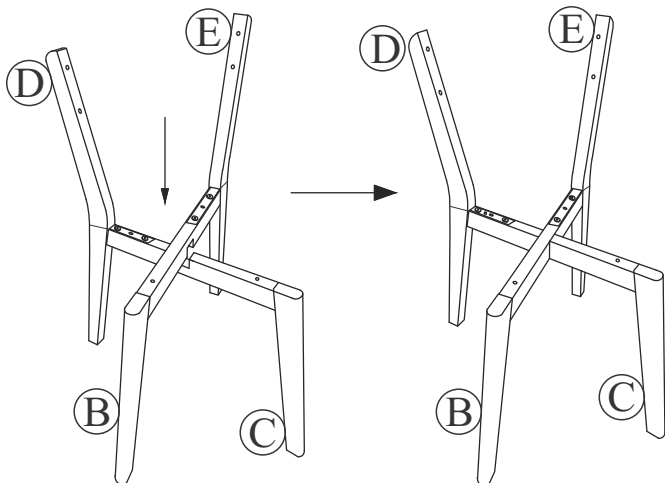
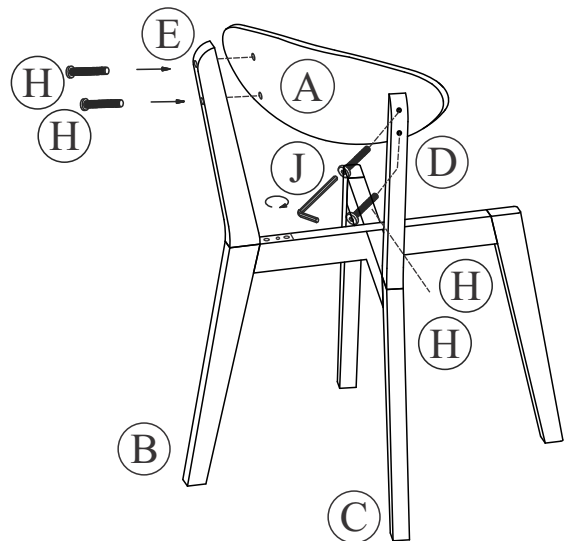
**3****4****5**