



[ In Australia or New Zealand ]  
PLEASE - BEFORE RETURNING TO STORE:

Contact Customer Service. We are glad to assist you with any parts or assembly problems you might have!

~

**Hunter Products Pty Ltd**

Phone: 1800 224 094

Email: enquiries@hunterproducts.com.au

Level 2, 424 Warrigal Road, Moorabbin,  
Victoria 3189 Australia.

<http://www.huffybikes.com/home/globalcontact>  
for current global contact information

For Assembly Help:

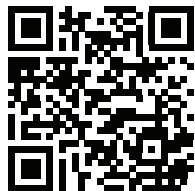

H-AU\_STOP-Contact\_2018



© Copyright Huffy Corporation 2018

## Owner's Manual Coaster Bicycles

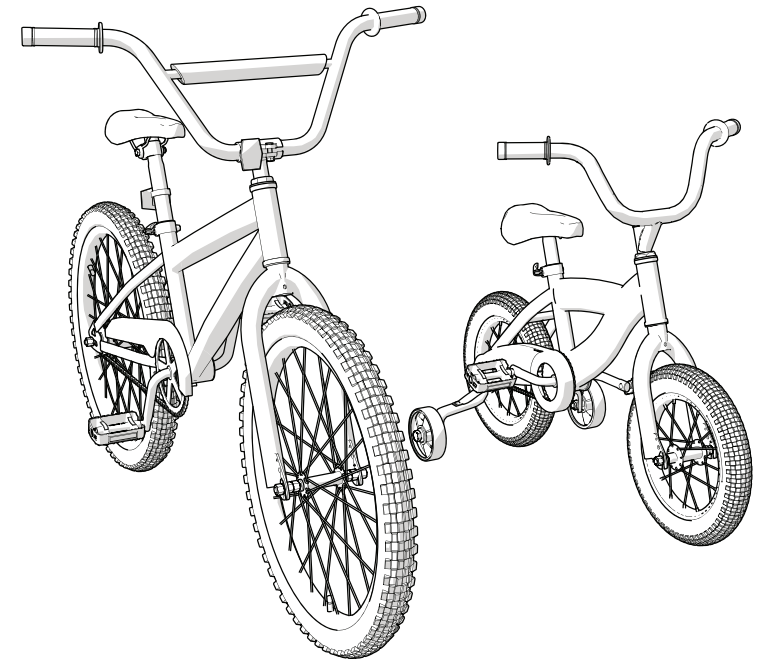

**This manual contains important safety, assembly, operation and maintenance information. Please read and fully understand this manual before operation.**

Save this manual for future reference.

Always wear approved helmet and safety equipment when using this product.



See back page for Customer Service Information  
Consulte el reverso para Servicio de Información al Cliente  
Voir pages verso pour des renseignements le service à la Clientèle

# Owner's Manual Index

## Your Bike

- Fitting the Rider to the Bicycle.....3
- Warning and Safety Information.....4
- The Owner's Responsibility.....4
- Rules of the Road / Reflectors.....5

## Bicycle Assembly

- Parts Assembly View.....6
- Parts Assembly List.....7
- Introduction to Assembly.....8
- Tools Needed.....8
- Installing the Front Wheel.....9
- Handlebar and Stem Installation..... 10-11
- Testing Stem and Handlebar Tightness..... 11
- Seat Installation (various models)..... 12-13
- Testing Seat Clamp and Post Clamp Tightness..... 14
- Front and Rear Reflector Installation..... 14
- Pedal Installation..... 15
- Training Wheel Installation (various models)..... 16-17
- Brake System Setup (various models)..... 18-21
- Brake Pad Replacement..... 21
- Coaster Brake..... 22

## Accessories - various models

- Streamers, Handlebar Pad and Bag.....23
- Plaques Installation.....24
- Bell and Handlebar Features.....25

## Maintenance and Service

- Repair and Service / Torque Table.....26
- Tires / Tire Pressure Table.....27
- Inspection of the Bearings.....28
- Chain Adjustment.....28
- Lubrication and Lubrication Table.....29

## Warranty

- Limited Warranty.....30

## Contact Information - Back Page

## Owner's Bicycle Identification Record

**NOTE:** This information is only available on the bicycle itself.

Each bicycle has a Recovery Code stamped into the frame. The Recovery Code ① can be found on the bottom of the crank housing as shown.

Write this number below to keep it for future reference.

If the bicycle is stolen, give this number and a description of the bicycle to the police. This will help them find the bicycle.

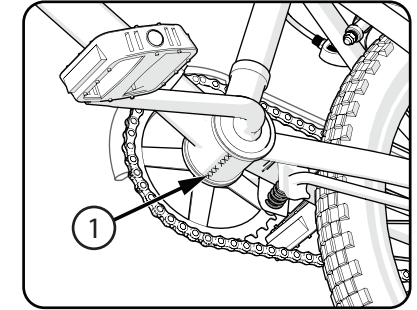

**Recovery Code:** \_\_\_\_\_

**Purchase Date:** \_\_\_\_\_

**Model Name:** \_\_\_\_\_

## Limited Warranty (Australia)

### General:

Part or model specifications are subject to change without notice.

This Limited Warranty is the only warranty for the product. ALL WARRANTIES OTHER THAN STATED HEREIN ARE DISCLAIMED INCLUDING IMPLIED WARRANTIES OF MERCHANTABILITY AND FITNESS FOR A PARTICULAR PURPOSE, TO THE EXTENT ALLOWABLE BY APPLICABLE LAW. ALL LIABILITY FOR INCIDENTAL, PUNITIVE, SPECIAL, OR CONSEQUENTIAL DAMAGES ARE EXPRESSLY DISCLAIMED, TO THE EXTENT ALLOWABLE BY APPLICABLE LAW.

The only uses for this product are described in this manual.

Warranty registration is not required.

The Limited Warranty extends only to the original consumer and is not transferable to anyone else.

### What does this Limited Warranty cover?

This Limited Warranty covers defects in workmanship and materials for all parts of the product except those indicated below as not warranted.

### What must you do to keep the Limited Warranty in effect?

*This Limited Warranty is effective only if:*

- Product is completely and correctly assembled.
- Product is used under normal conditions for its intended purpose (see the following section for excluded activities).
- Product receives all necessary maintenance and adjustments.
- Product is used for general transportation and recreational use only.

### What is not covered by this Limited Warranty?

This product is designed for recreational use only. This Limited Warranty does not cover normal wear and tear, normal maintenance items, or any damage, failure, or loss that is caused by improper assembly, maintenance, adjustment, storage, or use of the product. This Limited Warranty does not extend to future performance.

### This Limited Warranty will be void if the product is ever:

- Used in any competitive sport
- Used for stunt riding, jumping, aerobatics or similar activity
- Modified in any way
- Modified with the addition of a motor

- Ridden by more than one person at a time
- Rented, sold, or given away
- Used in a manner contrary to the instructions and warnings in this Owner's Manual

### What will The Manufacturer do?

Manufacturer's sole and exclusive obligation under this Limited Warranty is to repair and/or replace, at its sole option, any covered defect in workmanship or materials.

### How do you report a problem with this product or submit a warranty claim?

- Contact Customer Service in Australia or New Zealand (See included list for Customer Contact information).
- Warranty claims can be submitted to; Hunter Products Pty Ltd - PH: 1800 224 094 Email: enquiries@hunterproducts.com.au - Level 2, 424 Warrigal Road, Moorabbin, Victoria 3189 Australia.

*The following text is incorporated into this Limited Warranty if this product was purchased in Australia (but it is not incorporated if such product was purchased in New Zealand):*

- Our goods come with guarantees that cannot be excluded under the Australian Consumer Law. You are entitled to a replacement or refund for a major failure and for compensation for any other reasonably foreseeable loss or damage. You are also entitled to have the goods repaired or replaced if the goods fail to be of acceptable quality and the failure does not amount to a major failure.

### What rights do you have?

This Limited Warranty gives you specific legal rights. You may also have other rights which vary from State to State.

### For how long does this Limited Warranty last?

- When used in this Limited Warranty, the phrase "for life" means for as long as the original consumer owns the product.
- The frame is warranted for life except aluminum frames which are warranted for ten (10) years, from the date of purchase.
- The fork is warranted for life except for shock forks which are warranted one (1) year from date of purchase.
- All other components are warranted for six (6) months from the date of purchase.

## Helmet Warning Information

**! WARNING:**  
**ALWAYS WEAR YOUR HELMET**  
**WHEN RIDING THIS PRODUCT!**

- Helmet should sit level on your head and low on your forehead. Exposed forehead can result in serious injury.
- Adjust the strap sliders below the ear on both sides.
- Buckle the chin strap. Adjust strap until it is snug.
- No more than two fingers should fit between the strap and your chin.
- A proper fitting helmet should be comfortable and not rock forward/backward or side to side.

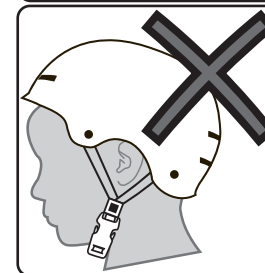
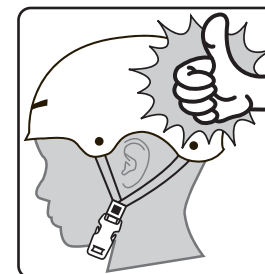

## Fitting the Rider to the Bicycle

### To determine the correct size of bicycle for the rider:

- Straddle the assembled bicycle with feet shoulder width apart and flat on the ground.
- There must be at least 1 inch (2.5 cm) of clearance ① between the highest part of the top tube ② and the crotch of the rider with tires properly inflated.
- The minimum leg-length for the rider is the highest part of the top tube plus one inch ③.
- **NOTE:** See Assembly sections for Seat adjustment.

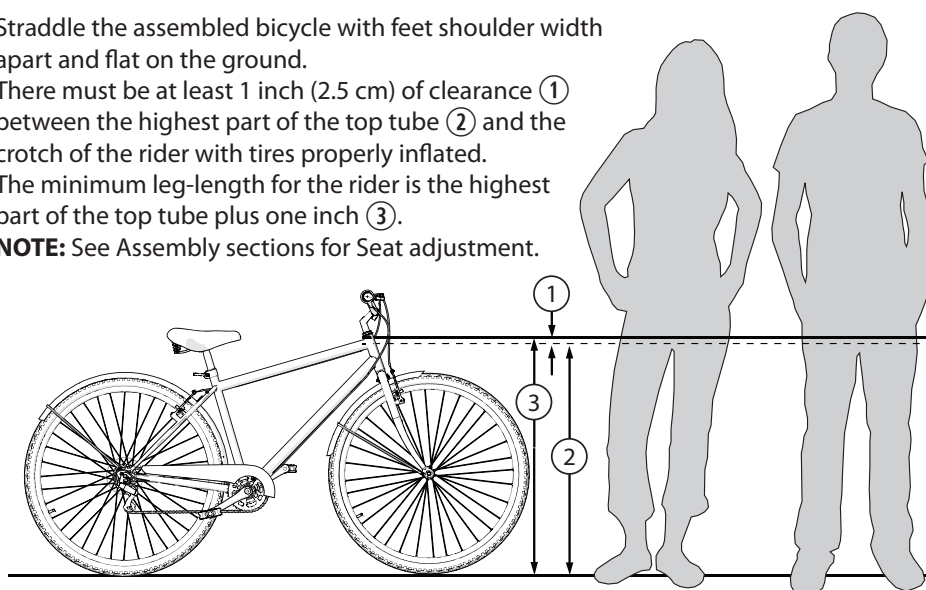

## Warning and Safety Information

### Meanings of Warnings:



This symbol is important. See the word **“CAUTION”** or **“WARNING”** which follows it. The word **“CAUTION”** is before mechanical instructions. If you do not obey these instructions, mechanical damage or failure of a part of the bicycle can occur. The word **“WARNING”** is before personal safety instructions. If you do not obey these instructions, injury to the rider or to others can occur.

- CHOKING HAZARD. Small parts. Not for children under 3 years.
- Adult assembly is required.
- Handlebar hand grip or tube end plugs should be replaced if damaged as bare tubes have been known to cause injury. All products with capped handlebar ends should be checked regularly to ensure that adequate protection for the ends of the handlebars are in place.
- Replacement forks must have the same rake and tube inner diameter as the original product.
- Do not add a motor to the product.
- Do not tow or push the product.
- Do not modify the product.
- Replace worn or broken parts immediately with original equipment.
- If anything does not operate properly, discontinue use.

### NOTE on HANDBRAKES:

#### In Australia/New Zealand/China:

- **Left Brake Lever** controls the **Rear Brake**
- **Right Brake Lever** controls the **Front Brake**

#### Most other countries:

- **Left Brake Lever** controls the **Front Brake**
- **Right Brake Lever** controls the **Rear Brake**

**NOTE:** The brake cables for front and rear brakes shall be positioned on the right or left brake lever according to the legislation or custom and practice of the country in which the bicycle is sold.

## The Owner’s Responsibility



**WARNING:** This bicycle is made to be ridden by one rider at a time for general transportation and recreational use. It is not made to withstand the abuse of stunting and jumping.

If the bicycle was purchased unassembled, it is the owner’s responsibility to follow all assembly and adjustment instructions exactly as written in this manual, and any “Special Instructions” supplied and to make sure all fasteners and components are securely tightened.

**NOTE:** Periodically check that all fasteners and components are securely tightened.

If the bicycle was purchased assembled, it is the owner’s responsibility, before riding the bicycle for the first time, to make sure the bicycle has been assembled and adjusted exactly as written in this manual, and any “Special Instructions” supplied and to make sure all fasteners and components are securely tightened.

### NOTE:

**If product is assembled, please proceed to sections:**

- Testing Stem, Handlebar
- Seat Clamp tightness.

## Lubrication



### WARNING:

- Do not over lubricate. If oil gets on the wheel rims or the brake shoes, it will reduce brake performance and a longer distance to stop the bicycle will be necessary. Injury to the rider or to others can occur.
- The chain can throw excess oil onto the wheel rim. Wipe excess oil off the chain.
- Keep all oil off the surfaces of the pedals where your feet rest.
- Using soap and hot water, wash all oil off the wheel rims, the brake shoes, the pedals, and the tires.
- Rinse with clean water and dry completely before you ride.
- Using a light machine oil (20W), lubricate the bicycle according to the following table:

### Lubrication Table (as equipped)

What	When	How
Pedals	every six months	Put four drops of oil where the axles go into the pedals.
Chain	every six months	Put one drop of oil on each roller of the chain. Wipe all excess oil off the chain.
Derailleurs	every six months	Put one drop of oil on each pivot point of the derailleurs.
Brake Levers	every six months	Put one drop of oil on the pivot point of each brake lever.
Wheel Brakes	every six months	Put one drop of oil on the pivot point of each cantilever brake.
Brake and cable	every six months	Put four drops of oil into both ends of each cable. Allow oil to soak back along the cable wire.
Rear Sprocket Cluster	every six months	Lay the bicycle on its left side. Slowly turn the rear wheel clockwise. Put four drops of oil in the crack between the rear sprockets (which are stationary) and the freewheel body (which is turning clockwise).
Shock Fork	every six months	Lift up the rubber fork boot and dab a small amount of grease on the fork leg just above the plastic bushing.

## Inspection of the Bearings

### MAINTENANCE

Frequently check the bearings of the bicycle. Lubricate the bearings once a year or any time they do not pass the following tests:

#### HEAD TUBE BEARINGS

The fork should turn freely and smoothly at all times. With the front wheel off the ground, you should not be able to move the fork up, down, or side-to-side in the head tube.

#### CRANK BEARINGS

The crank should turn freely and smoothly at all times and the front sprockets should not be loose on the crank. You should not be able to move the pedal end of the crank from side-to-side.

#### WHEEL BEARINGS

Lift each end of the bicycle off the ground and slowly spin the raised wheel by hand. The bearings are correctly adjusted if:

- The wheel spins freely and easily.
- The weight of the spoke reflector, when you put it toward the front or rear of the bicycle, causes the wheel to spin back and forth several times.
- There is no side-to-side movement at the wheel rim when you push it to the side with light force.

## Chain Adjustment

### ! WARNINGS:

- The chain must remain on the sprockets. If the chain comes off the sprockets, the coaster brake will not operate.
- Do not attempt chain repairs. If there is a problem with the chain, have a bicycle service shop make any repairs.

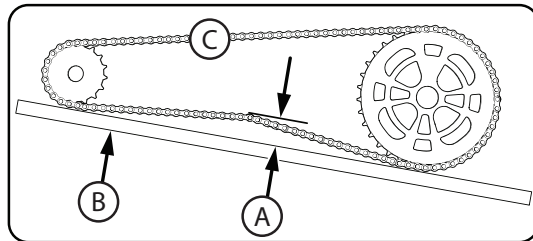

#### Adjustment:

The chain must be at the correct tightness. If too tight, the bicycle will be difficult to pedal. If too loose, the chain can come off the sprockets.

When the chain (C) is at the correct tightness, you can rotate the crank freely and you can pull it no more than one-half inch (A) away from a straightedge (B) as shown.

#### Adjust the tightness of the chain as follows:

- Loosen the axle nuts of the rear wheel.
- Move the rear wheel forward or backward as necessary.

**NOTE:** Make sure the rear wheel is in the center of the bicycle frame.

- Hold the wheel in this position and tighten securely.

## Rules of the Road

**! WARNING:** Failure of the rider to obey the following “Rules of the Road” can result in injury to the rider or to others.

- It is the responsibility of parents or carers to ensure child is properly instructed in the use of this bicycle, particularly in the safe use of the braking systems (especially the back-pedal/coaster brake).
- Obey all traffic regulations, signs, and signals.
- Always wear a bicycle helmet that meets CPSC safety standards, as well as local safety standards.
- Always wear shoes.
- Ride on the correct side of the road, in a single file, and in a straight line.
- **Bikes 12in (30cm) and under not intended for use on public roads.**
- Avoid riding at night, dusk, dawn and any other time of poor visibility.
- Ensure all spares, (tyres, tubes, and brake pads, etc) are same as original equipment.
- **Reflectors:** For your own safety, do not ride the bicycle if the reflectors are incorrectly installed, damaged, or missing. Make sure the front and rear reflectors are vertical. Do not allow the visibility of the reflectors to be blocked by clothing or other articles. Dirty reflectors do not work well. Clean the reflectors, as necessary, with soap and a damp cloth.
- **Use extra caution in wet weather:**
  - Ride slowly on damp surfaces because the tires will slide more easily.
  - Allow increased braking distance in wet weather.
- **Avoid these hazards to prevent loss of control or damage to your wheels:**
  - Be aware of drain grates, soft road edges, gravel or sand, pot holes or ruts, wet leaves, or uneven paving.
  - Cross railroad tracks at a right angle to prevent the loss of control.
  - Avoid unsafe actions while riding.
  - Do not carry any passengers.
  - Do not carry any items or attach anything to your bicycle that could hinder your vision, hearing, or control.
  - Do not ride with both hands off the handlebar.
  - This bicycle is not suitable for the fitting of a luggage carrier and (or) a child seat.

### Maximum rider/bike weight for this product is as follows:

Bike Size	Rider		Rider + Bike	
	kg	lbs	kg	lbs
12	27	60	34.3	76
14	27	60	34.7	77
16	27	60	35.6	79
18	34	72	43.5	93

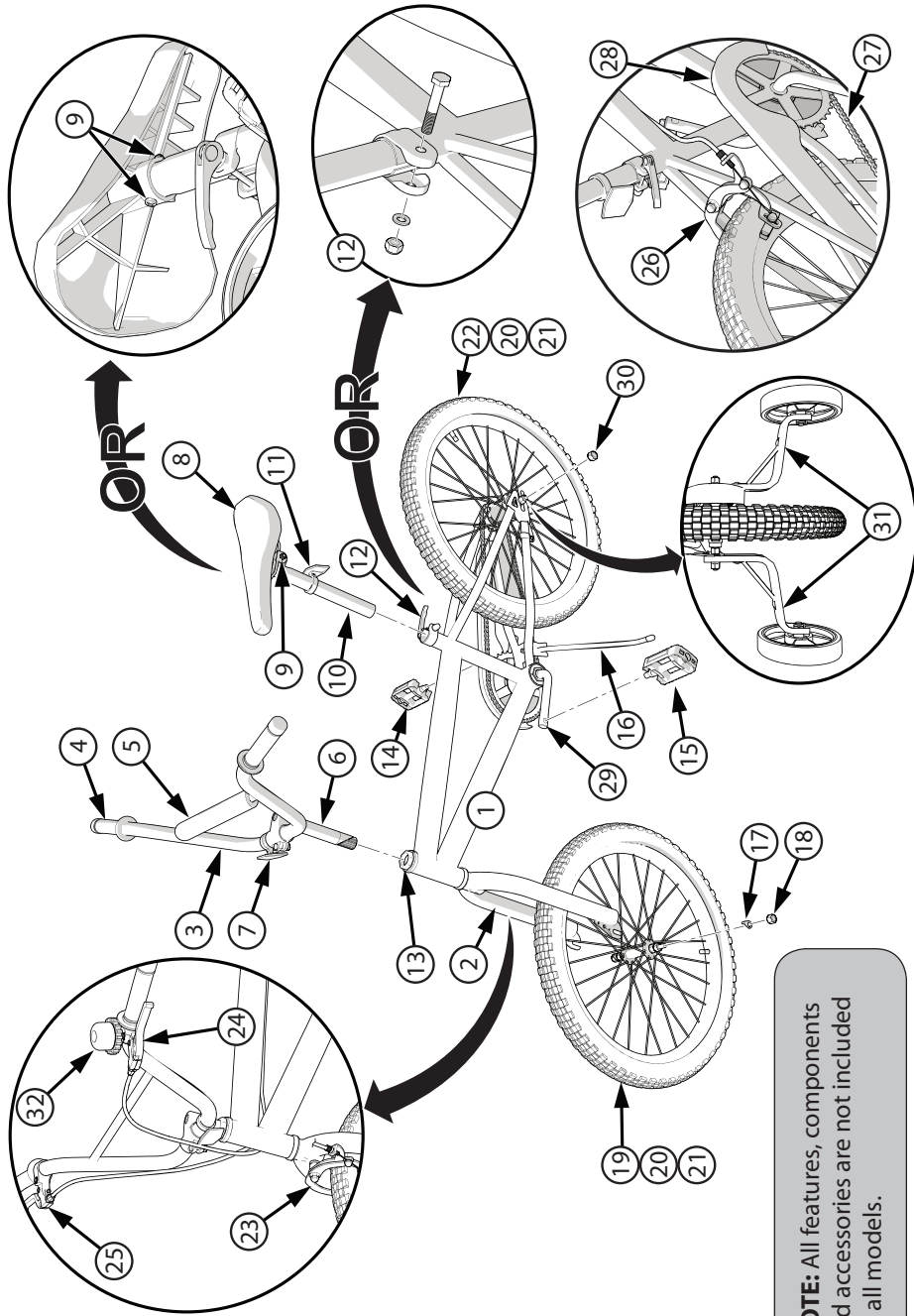

**NOTE:** All features, components and accessories are not included on all models.

**Tires - AU**

**Maintenance:**

- Frequently check the tire inflation pressure because all tires lose air slowly over time. For extended storage, keep the weight of the bicycle off the tires.
- Do not use unregulated air hoses to inflate the tire/tubes. An unregulated hose can suddenly over inflate bicycle tires and cause them to burst.
- Replace worn tires.

**! WARNING:** Do not ride or sit on the bicycle if a tire is under inflated. This can damage the tire, inner tube and rim.

**Inflating the Tires:**

- Use a hand or a foot pump to inflate the tires.
- Service station meter-regulated air hoses are also acceptable.

- The maximum inflation pressure is shown on the tire sidewall.
- If two inflation pressures are on the tire sidewall, use the higher pressure for on-road riding and the lower pressure for off-road riding.
- The lower pressure will provide better tire traction and a more comfortable ride.

Before adding air to any tire, make sure the edge of the tire (the bead) is the same distance from the rim, all around the rim, on both sides of the tire. If the tire does not appear to be seated correctly, release air from the inner tube until you can push the bead of the tire into the rim where necessary. Add air slowly and stop frequently to check the tire seating and the pressure, until you reach the correct inflation pressure.

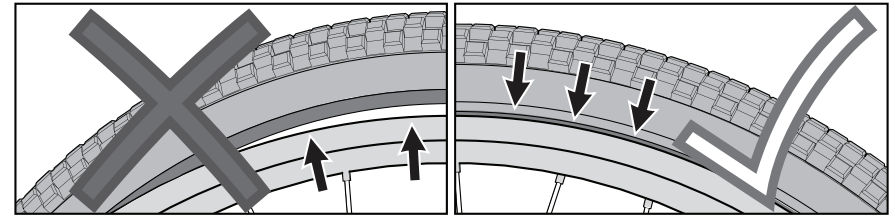

**Recommended Tire Pressure (kilopascals):**

Frequently check the tire inflation pressure because all tires lose air slowly over time. For extended storage, keep the weight of the product off the tires.

Recommended tire pressure is marked on the side of the tire. Conversion from PSI to Kilopascals:

PSI	Kpa
20	140
30	210
40	275
50	345
60	415

## Maintenance, Repair and Service

### WARNING:

This product should be checked periodically for any loose, broken, or worn parts. Tighten any parts that are loose, and replace any worn or broken parts immediately with original equipment. Periodic cleaning will prolong the useful life of this product

#### SELF-LOCKING FASTENERS:

With repeated use, Self-Locking Fasteners may lose their ability to lock to the threads and may come loose. Frequently check Self-Locking Fasteners and replace when worn.

#### INSPECTION OF THE BEARINGS:

Frequently check the wheel bearings of the product. Replace the wheels when the bearings do not pass the following tests:

Lift each end of the product off the ground and spin the raised wheel by hand:

- The wheel should spin freely and easily.
- There should be no side-to-side movement at the wheel edge when pushed to the side with light force.

#### WEEKLY SERVICE:

Apply a few drops of general purpose oil to the sides of each wheel axle. Verify that the axle fasteners are tight.

## Torque Table

#### Recommended Torque:

Use of a torque wrench is recommended. Recommended torque for each fastener is listed below. In addition to tightening to the recommended torque, please ensure the parts of the product are sufficiently tightened by performing the functional tests (in the component assembly sections of the owner's manual) on each component as it is tightened.

**NOTE:** Please check that all fasteners on the product are torqued according to the table below:

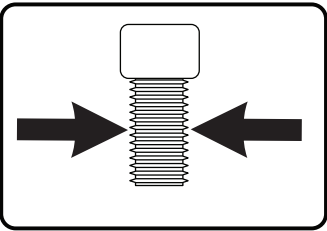
Recommended Torque for clean, dry threads:		How to Measure:
Fastener Size	Torque (ft-lb / N•m)	Screw or bolt size is determined by the width at the THREADS as shown.
.157 in (4 mm)	3.1 ft-lbs (4.2 N•m)	
.196 in (5 mm)	5 ft-lbs (6.8 N•m)	
.236 in (6 mm)	7 ft-lb (9.5 N•m)	
.275 in (7 mm)	12 ft-lbs (16.3 N•m)	
.314 in (8 mm)	17 ft-lbs (23 N•m)	
.393 in (10 mm)	33 ft-lbs (44.7 N•m)	
Pedals	24 ft-lbs (30 N•m)	

## Parts List

### Parts Assembly List

No.	Description	No.	Description
1	Frame	20	Tire (x2)
2	Fork	21	Tube (x2)
3	Handlebars	22	Rear Wheel Assembly
4	Grips (x2)	23	Front Brake
5	Handlebar Pad (some models)	24	Left Brake Lever
6	Handlebar Stem	25	Right Brake Lever
7	Front Reflector	26	Rear Brake
8	Seat	27	Chain
9	Seat Post Hardware	28	Chain Guard
10	Seat Post	29	Crank and Spindle Set
11	Rear Reflector	30	Rear Wheel Nut (x2)
12	Quick Release and Lever Nut	31	Training Wheel Set - 12-18" (30-45cm bikes)
13	Head Set Bearings		
14	Right Pedal		<b>Accessories (various models)</b>
15	Left Pedal	32	Bell
16	Kick Stand	33	Handlebar Bag (not shown)
17	Wheel Retainer (x2)	34	Streamers (not shown)
18	Front Wheel Nut (x2)	35	Plaque (not shown)
19	Front Wheel Assembly		

## Introduction to Assembly

THIS OWNER'S MANUAL IS MADE FOR SEVERAL DIFFERENT BICYCLES:

- Some illustrations may vary slightly from the actual product.
- Follow instructions completely.
- If the bicycle has any parts that are not described in this manual, look for separate "Special Instructions" that are supplied with the bicycle.
- Models may have different accessory items such as bags, baskets, reflectors, cup holders, racks, etc.
- All features, components and accessories are not included on all models.
- Use the Index page to locate specific sections of this manual.
- Please read through this entire manual before beginning assembly or maintenance.
- If you are not confident with assembling this unit, refer to a local bike shop.

**⚠ WARNING:** Keep small parts away from children during assembly.

Do not dispose of the carton and packaging until you complete the assembly of the bicycle. This can prevent accidentally discarding parts of the bicycle.

**NOTE:** All of the directions (right, left, front, rear, etc.) in this manual are as seen by the rider while seated on the bicycle.

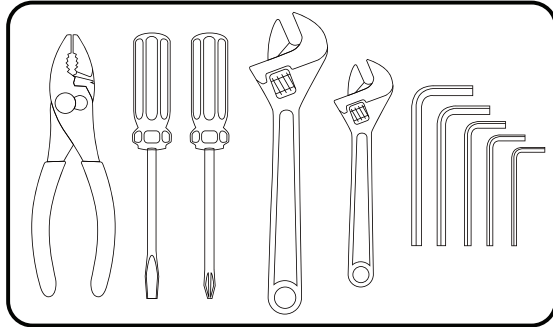

### Tools Needed

(Metric)

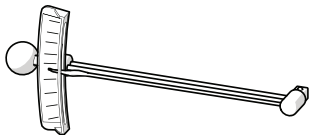

**Torque Wrench (recommended)**

## Bell and Handlebar Features (various models)

### Bells and Features:

- If the mounting Screw (A) is factory installed, remove it and set aside.
- Open the Clamp (B) just enough to fit on the handlebar.
- Position the Bell / Accessory so that is level and positioned as shown.
- Tighten Screw securely. Do not over-tighten. This can damage the Clamp.

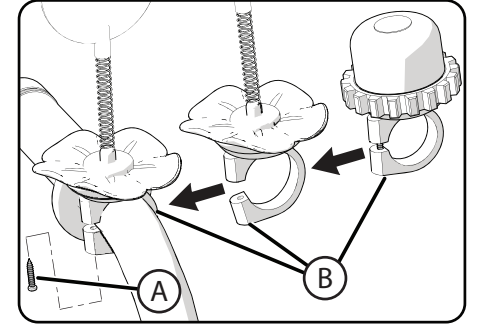



## Plaques Installation (various models)

### 1: Bracket Mount:

- Attach Plaque (A) to Handlebar Cross Brace (B) using supplied Clamps (C) and Screws (D).
- Tighten Screws so that the Plaque does not move.
- Do not over-tighten Screws. This may damage the Plaque.

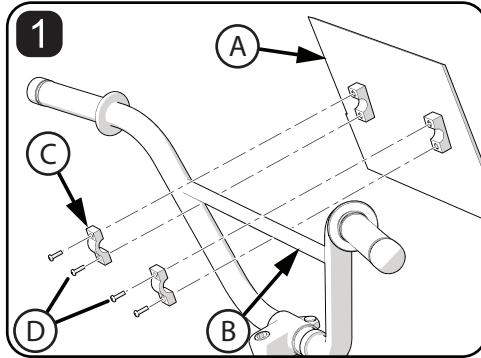

### 2: Zip-Tie Mount:

- Position Plaque against Handlebar.
- Attached with supplied Zip-Ties. Do not over tighten, this can break the Zip-Ties.

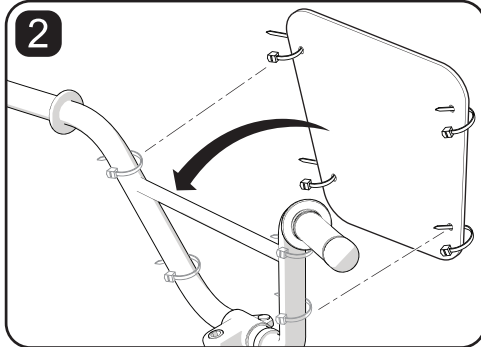

**NOTE:** Plaques may mount with 2 or more Zip-Ties.

### 3: Hook and Loop Mount:

- Open the straps on the Plaque and wrap them around the Handlebar or Brace (B).
- If Handlebar Pad is in place, wrap straps around the Handlebar Pad.
- Make sure the straps are secure.

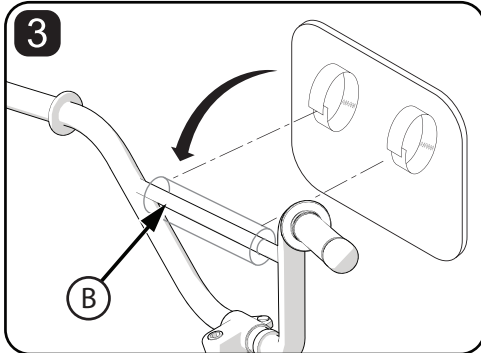

### ⚠ WARNING:

- Ensure Plaque does not interfere with child's visibility or ability to control the product.
- Make sure front Reflectors are not blocked by Plaque.

## Installing the Front Wheel

**NOTE:** See Brake Section to loosen and Re-attach front Brakes (if equipped).

1. If the Axle Nuts (A) are already attached to the front wheel axle, begin by removing them with an open end wrench or adjustable wrench.
2. Set the wheel into the front fork (B).
3. Install wheel retainers (C) making sure the tabs are in the fork (D) tab holes.
4. Attach the front wheel with the Axle Nuts.
5. Put the wheel in the center of the fork and tighten Axle Nuts securely.

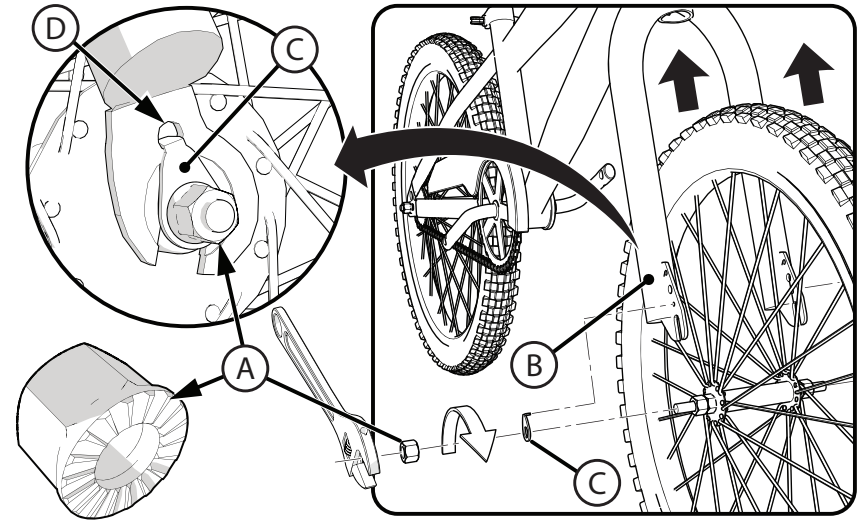

**NOTE:** Ensure wheel spins freely without contacting fork or fender.

**⚠ WARNING:** Do not use Nuts (A) without serrations to attach the front wheel.

**⚠ WARNING:** Failure to obey these steps can allow the front wheel to loosen while riding. This can cause injury to the rider or to others.

## Handlebar and Stem Installation

**! WARNING:** To prevent steering system damage and possible loss of control, the "MIN-IN" (minimum insertion) mark (A) on the stem must be below the top of the Locknut (B).

**NOTE:**

- Remove plastic Cap (C) from the end of the Stem (D).
- Some models have a one piece handlebar and stem.
- If model has stem mounted Reflector (E), make sure it is ABOVE the MIN-IN marks, pointing forward and tightened securely.

**STEPS:**

1. Insert the Stem (D) into the fork (fig A).
2. Point the Stem towards the front of the bike.
3. Tighten the Stem Bolt (F) just enough to hold it in position.
4. If necessary, loosen the Handlebar Clamp Nut/Screw (G) and rotate Handlebar into a comfortable riding position (fig A, B).
5. Tighten Handlebar Clamp Nut/Screws (G) just enough to hold it in position.
6. Align the stem with the front tire and tighten the Stem Bolt (F) securely.

**! WARNING:** Do not over-tighten the stem bolt. Over tightening the stem bolt can damage the steering system and cause loss of control.

**Four Bolt Clamp (fig B):**

- If necessary, re-adjust Handlebar for proper fit.
- Tighten Clamp Screws (G) evenly according to pattern.

**NOTE:** Do not over tighten.

**! WARNING:** If the handlebar clamp is not tight enough, the handlebar can slip in the stem. This can cause damage to the handlebar or stem, and can cause loss of control.

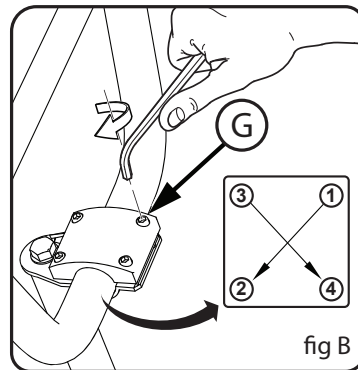
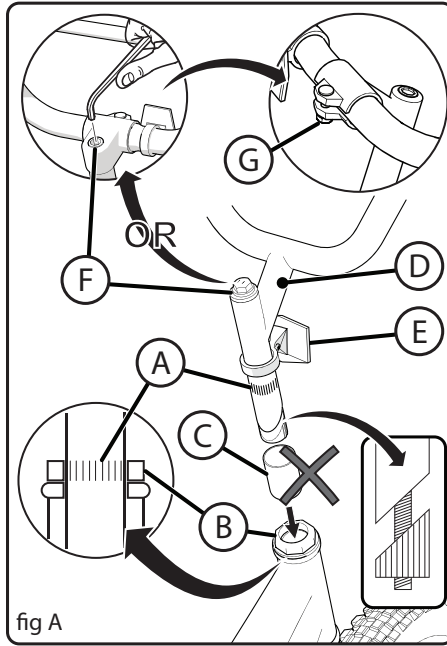

## Streamers, Pad and Bags (various models)

**NOTE: NOT ALL BIKES HAVE ALL ACCESSORIES!**

**Handlebar Pad:**

- Remove the cover from the Handlebar pad (A)
- Push foam pad over handlebar brace (B)
- Wrap handlebar pad cover around foam pad and close with the Hook and Loop strip

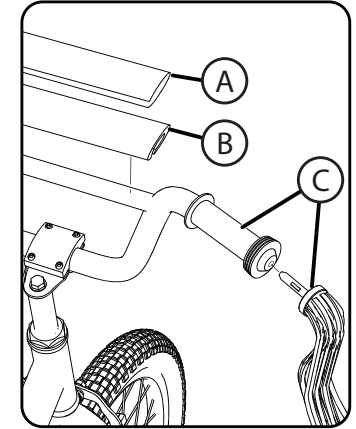

**Streamers:**

- Insert each Streamer (C) in the hole in the end of each Handlebar Grip
- Ensure Streamer is fully inserted so that it does not come loose

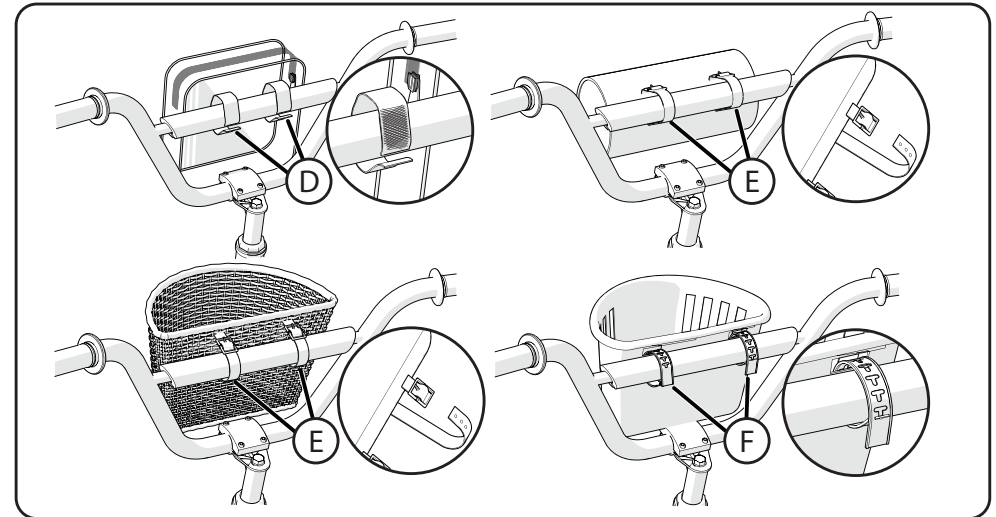

**The following attachment methods may be used - attach accordingly:**

- Hook and Loop (D)
- Strap and Buckle (E)
- T-Peg and Slot (F)

**Attached Straps securely. Do not over-tighten.**

**! WARNINGS:**

- Make sure front reflectors are not blocked by Bags or Baskets.
- Handlebar Bag/Basket weight limit: 5 lbs (2.3kg).

**See Torque Chart for Recommended Fastener Torque**

### Coaster Brakes - various models

These models are equipped with a rear 'coaster' brake that is operated by rotating the crank backwards.

**FUNCTION:**

Operate the coaster brake as follows:

- Push the pedals backward to move the chain backward
- The chain activates the coaster brake mechanism that is inside the rear wheel hub
- As you push the pedals backward with increasing force, the braking action of the coaster brake increases.

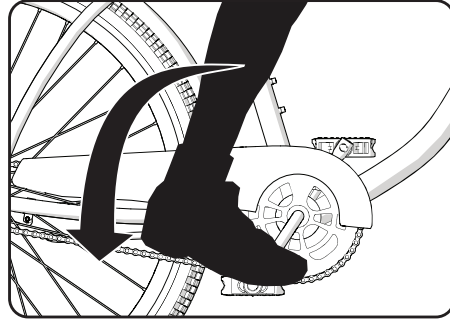

If your bicycle has a caliper brake(s) in addition to the coaster brake, always use the coaster brake as the main brake to stop the bicycle.

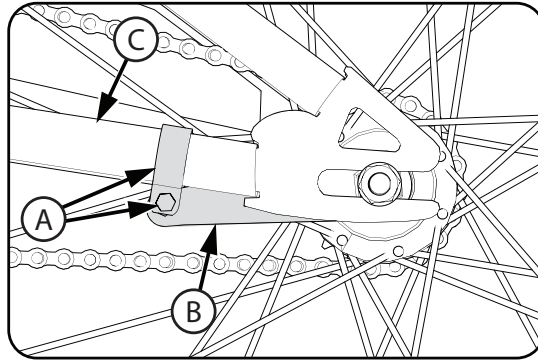

**WARNING:** If you do not obey the following instructions, injury to the rider or to others can occur :

- When you ride the bicycle the first time, test the coaster brake and practice using it at a low speed in a large level area that is free of obstructions.
- Every time the bicycle is ridden, make sure the clamp (A) on the brake arm (B) is securely attached to the chain stay (C) of the bicycle frame. The coaster brake will not work correctly if the brake arm is not attached to the chain stay.

### Handlebar and Stem Installation - continued

**One Bolt Clamp (fig C):**

- If necessary, re-adjust Handlebar for proper fit.
- Tighten Clamp Nut/Bolt (G).

**NOTE:** Do not over tighten.

**WARNING:** If the handlebar clamp is not tight enough, the handlebar can slip in the stem. This can cause damage to the handlebar or stem, and can cause loss of control.

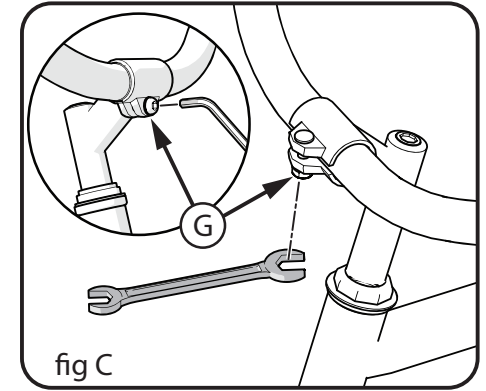

### Testing Stem and Handlebar Tightness

**To test the tightness of the stem:**

- Straddle the front wheel between your legs.
- Try to turn the front wheel by turning the handlebar.
- If the handlebar and stem turn without turning the front wheel, realign the stem with the wheel and tighten the stem bolt(s) tighter than before (about 1/2 revolution only at a time).
- Do this test again, until the handlebar and stem do not turn without turning the front wheel.

**To test the tightness of the handlebar clamp:**

- Hold the bicycle stationary and try to move the ends of the handlebar up and down or forward and back.

**WARNING:** Do not exceed 100 lbs (45 kg) force.

- If the handlebar moves, loosen the bolt(s) of the handlebar clamp.
- Put the handlebar in the correct position and tighten the bolt(s) of the handlebar clamp tighter than before.
- If the handlebar clamp has more than one bolt, tighten the bolts equally.
- Do this test again, until the handlebar does not move in the handlebar clamp.

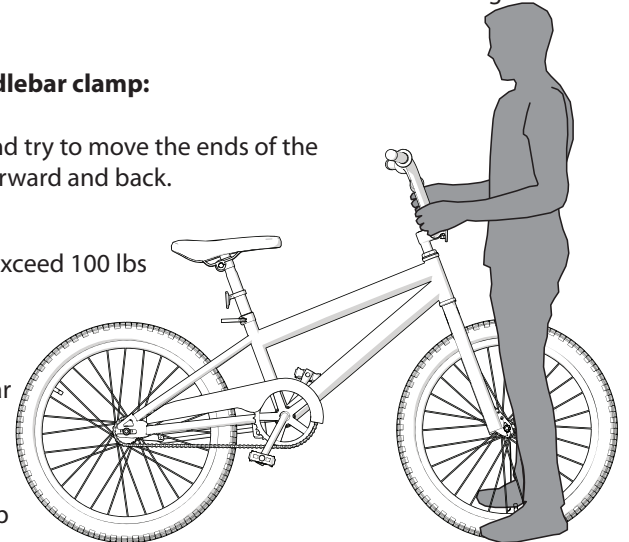

## Seat Installation (various models)

**Seat to Seat Post (Single Bolt Style):** Some models are equipped with a seat and seat post assembly that uses a single bolt and nut to secure the seat to the seat post. The seat is assembled to the seat post at the factory (A).

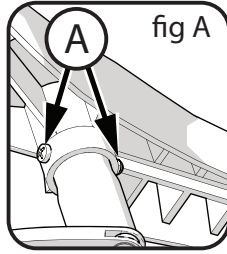

Ensure the seat is secure to the seat post and the seat bolt is tightened.

**WARNING:** To prevent the seat coming loose and possible loss of control, the “MIN-IN” (minimum insertion) mark (B) on the Seat Post must be below the top of the Seat Tube (C).

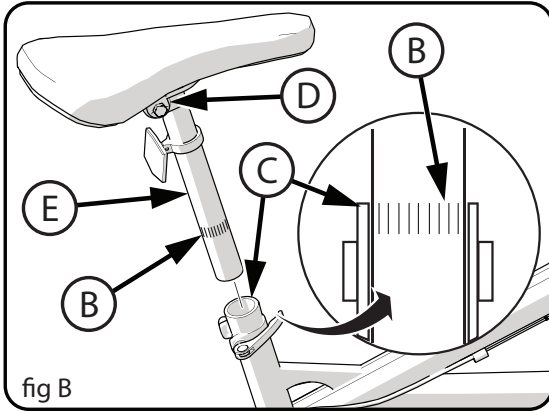

### SEAT AND SEAT POST SETUP:

1. If needed, loosen Nuts on Seat Clamp (D) and rotate Seat into riding position.
2. Ensure the Seat Post (E) is fully through the TOP Seat Clamp (D).
3. Tighten the Seat Clamp so the Seat does not move on the seat post.
4. If the Seat Clamp has a Nut on each side, tighten both nuts equally.
5. Point the Seat forward and put the Seat Post (E) into the Seat Tube (C) and proceed to next step.

### TIGHTEN THE QUICK RELEASE LEVER:

**NOTE:** The words “open” and “close” are on opposite sides of the quick release lever.

1. Move the Quick Release Lever (F) to the “open” position so the word “open” is pointing away from the Seat Post Clamp (G).

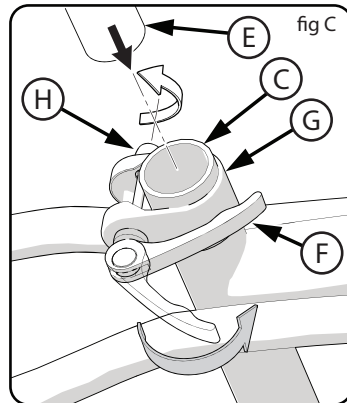

**CAUTION:** Operate the Quick Release Lever (F) by hand only. Do not use a hammer or any other tool to tighten the quick release lever.

2. You must use strong force to move the quick release lever to the “close” position. If you can easily move the lever to the “close” position, the clamping force is too light.

## Caliper Rim Brake System Setup - continued

### Step 8:

- Make sure the cable sheaths are fully inserted into the adjustment housing at the Caliper (8-1) and Hand Lever (8-2).

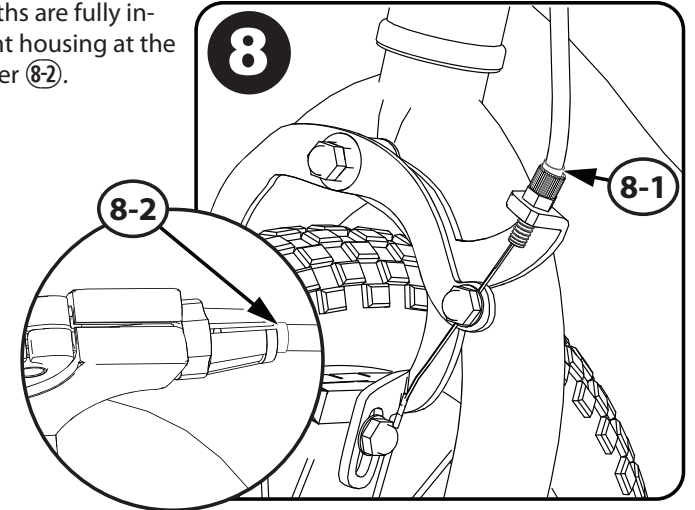

### Step 9:

- Rotate Brake Levers (A) into a comfortable riding position and tighten securely.

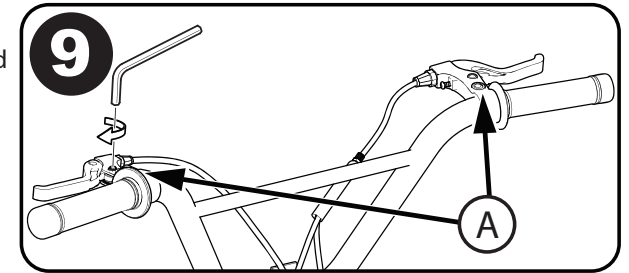

## Brake Pad Replacement

1. If necessary, loosen brake cable Adjustment Bolt (A).
2. Loosen and remove brake pad Bolt/Screws (B).
3. Remove old Brake Shoe (C).
4. Install new Brake Shoe, making sure it is pointing forward and lined up evenly with the Wheel Rim (D).
5. Tighten brake pad Bolt/Screw securely.

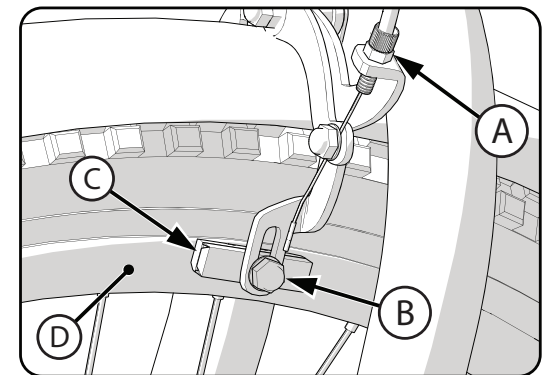

**WARNING:** Replace Brake Pad with same model and type as original.

coaster brakes >>

## Caliper Rim Brake System Setup - continued

### Step 5:

- Squeeze Brake Arms (5-1) so that Brake Pads (5-2) are against the Rim.

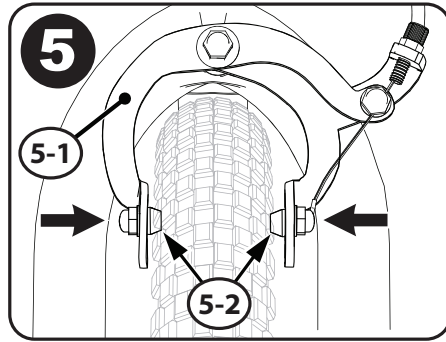

### Step 6:

- Pull Brake Cable (6-1) tight.
- Tighten Cable Nut (6-2).
- Adjust Cable Nut (6-3) for 1/16in (1.5mm) Brake Pad clearance.

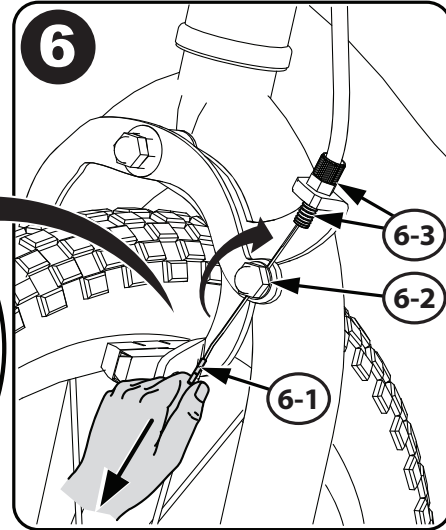
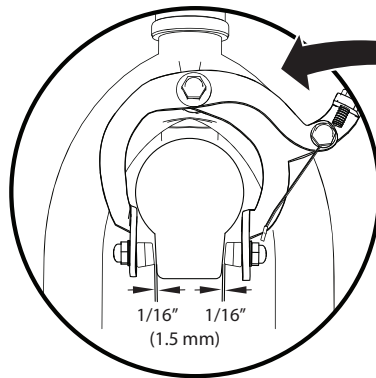

### Step 7:

- Make sure the Brake Lever is not loose (7-1).

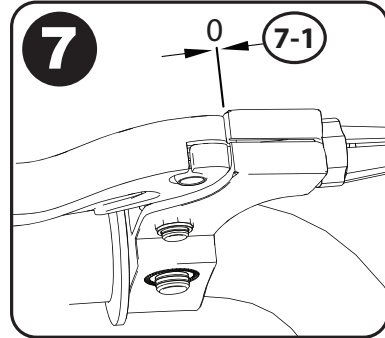

## Seat Installation - continued

**WARNING:** If the clamping force of the Quick Release Lever is too light, the seat post can loosen while riding. This can cause injury to the rider or to others.

### Tighten the quick release lever (fig C):

1. Open and close the Quick Release Lever with one hand while you turn the Adjusting Nut (H) with the other hand.
2. Tighten or loosen the adjusting nut by hand, so that you first feel resistance to the quick release lever when it perpendicular to the bicycle frame.
3. Push the Quick Release Lever to the "close" position.
4. When in the "close" position, make sure the Quick Release Lever lays against the Seat Post Clamp (G).
5. The tightening torque of the Quick Release Lever should be tight enough so that the seat does not move during normal operation.

## Seat Bolt Mount (various models)

Some models have a Bolt (I), Washer (J) and Nut (K) instead of a Quick Release Lever.

- If needed, loosen the nut enough to insert the Seat Post (E).
- Point the seat forward and insert Seat Post to the Minimum Insertion marks (B).
- Tighten Nut securely so it supports the rider without moving.

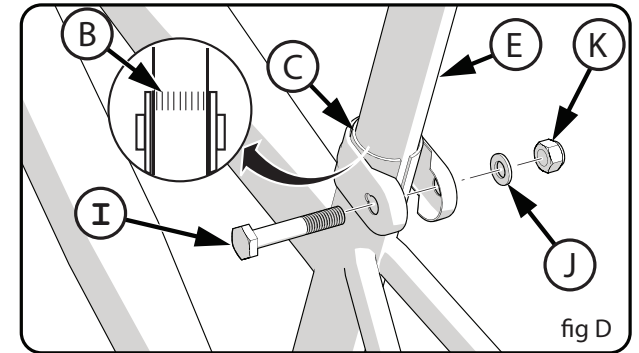

## Testing Seat Clamp and Post Clamp Tightness

To test the tightness of the seat clamp and the post clamp:

**WARNING:** Every time the quick release mechanism is loosened, make sure the red reflector is correctly positioned.

- Try to turn the seat side-to-side and to move the front of the seat up and down.
- **If the seat moves in the Seat Clamp:**
  - Loosen the Seat Clamp.
  - Put the seat in the correct position and tighten the Seat Clamp tighter than before.
  - Do this test again, until the seat does not move in the Seat Clamp.
- **If the Seat Post moves in the Seat Tube:**
  - Move the Quick Release Lever to the "open" position.
  - Put the seat in the correct position and tighten the Quick Release Lever tighter than before.
  - If necessary, loosen Quick Release Lever, tighten Adjusting Nut and re-tighten Quick Release Lever.
  - Do this test again, until the seat post does not move in the seat tube.

## Reflector Installation (as equipped)

### Reflector Installation:

1. Position FRONT Reflector (A) so it points straight forward.
2. Tighten Clamp Screw.
3. Position Seat Post Reflector (if equipped) (B) so it points straight backwards.
4. Tighten Clamp Screw.

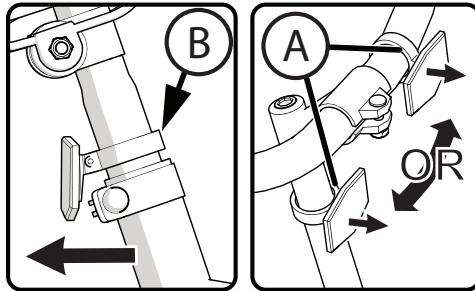

**NOTE:** Do not over-tighten. This will damage the Clamp.

### DUAL REAR REFLECTORS (VARIOUS MODELS):

The Rear Reflectors (A) are may be pre-installed on the bike chain stays. Make sure they are secure, not bent and are pointing straight backwards.

### Installation (as needed):

- Place Reflector (A) in position as shown and attached with two supplied Screws (B).
- Tighten securely. Do not over tighten.

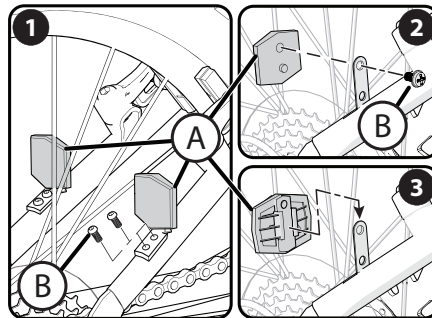

## Caliper Rim Brake System Setup - continued

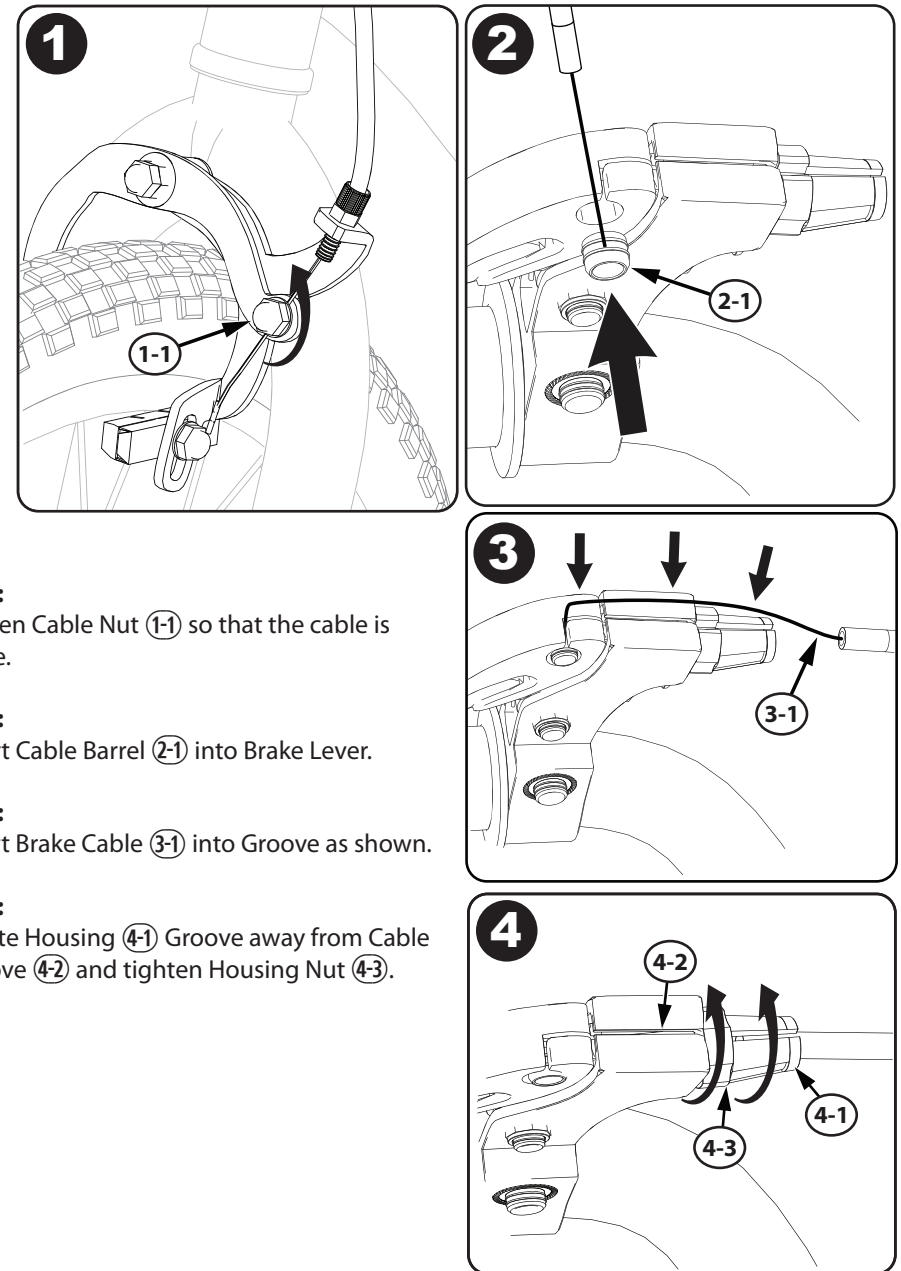

### Step 1:

- Loosen Cable Nut (1-1) so that the cable is loose.

### Step 2:

- Insert Cable Barrel (2-1) into Brake Lever.

### Step 3:

- Insert Brake Cable (3-1) into Groove as shown.

### Step 4:

- Rotate Housing (4-1) Groove away from Cable Groove (4-2) and tighten Housing Nut (4-3).

## Rim Brake System Setup (various models)

### NOTE on HANDBRAKES:

#### In Australia/New Zealand/China:

- **Left Brake Lever** controls the **Rear Brake**
- **Right Brake Lever** controls the **Front Brake**

#### Most other countries:

- **Left Brake Lever** controls the **Front Brake**
- **Right Brake Lever** controls the **Rear Brake**

**NOTE:** The brake cables for front and rear brakes shall be positioned on the right or left brake lever according to the legislation or custom and practice of the country in which the bicycle is sold.

**WARNING:** You must adjust the front brakes before you ride the bicycle.

**NOTE:** FRONT AND REAR BRAKE SETUP IS THE SAME.

**Step One:** Put the brake shoes (B) in the correct position:

- Loosen the Screw (A) of each Brake Shoe (B).
- Adjust each Brake Shoe so it is flat against the rim and aligned with the curve of the rim.
- Make sure each Brake Shoe does not rub the tire.
- If the surface of the Brake Shoe has arrows, make sure the arrows point toward the rear of the bicycle.
- Hold each Brake Shoe in position and tighten the Screw.

**Step Two: Test the tightness of each Brake Shoe:**

- Try to move each Brake Shoe out of position.
- If a Brake Shoe moves, do Step 1 again, but tighten the nut tighter than before.
- Do this test again, until each Brake Shoe does not move.

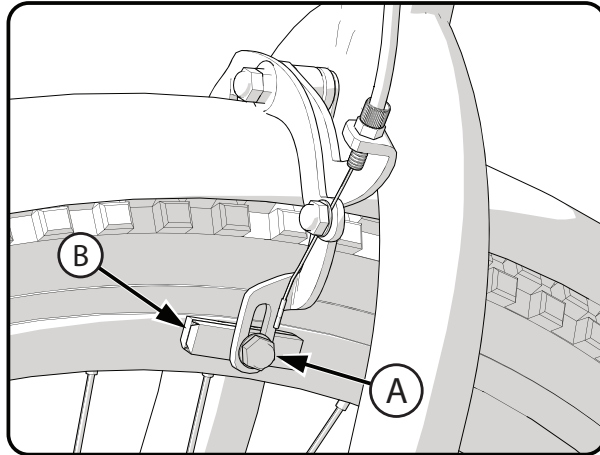

For Brake Pad replacement, see Maintenance section.

continued >>

See Torque Chart for Recommended Fastener Torque

## Pedal Installation

**CAUTION:** There is a RIGHT pedal marked (R) and a LEFT pedal marked (L).

**NOTE:** A Pedal Wrench is preferred for attaching Pedals. A thin open-end wrench can also be used.

- The pedal marked (R) has right-hand threads. Tighten it in a **clockwise direction**.
- The pedal marked (L) has left-hand threads. Tighten it in a **counterclockwise direction (anti-clockwise)**.
- Turn the right pedal marked (R) into the right side of the crank arm, and the left pedal marked (L) into the left side of the crank arm.

**Tighten the pedals:**

- Make sure the threads of each pedal are fully into the crank arm.

**WARNING:** Ensure pedals are secure in crank arms so they will not loosen. Periodically check tightness.

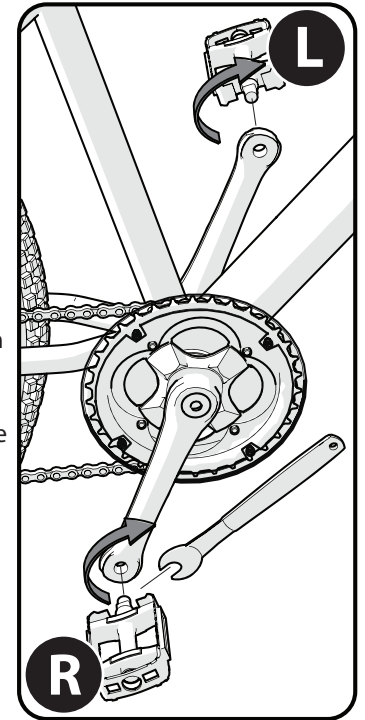

See Torque Chart for Recommended Fastener Torque

## Training Wheel Installation (various models)

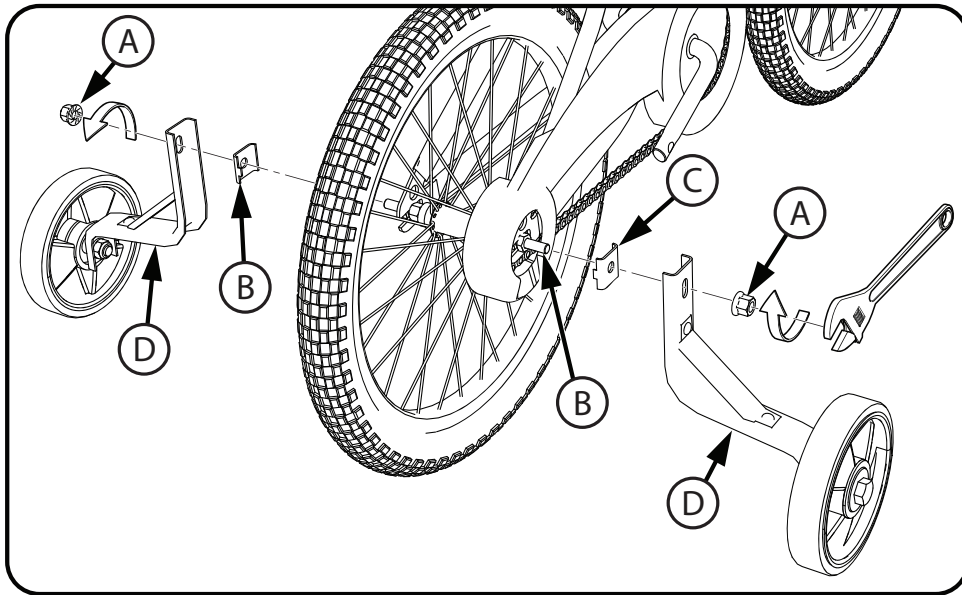

### To attach the Training Wheels to the Frame:

1. Remove outside Axle Nuts (A) from both sides of Axle (B).
2. Put the Alignment Tab (C), a Training Wheel Leg (D) and an Axle nut (A) on each end of the rear wheel Axle (B).

**WARNING:** Make sure the notched tab of the Alignment Tab (C) is to the rear of the axle and in the slot of the frame.

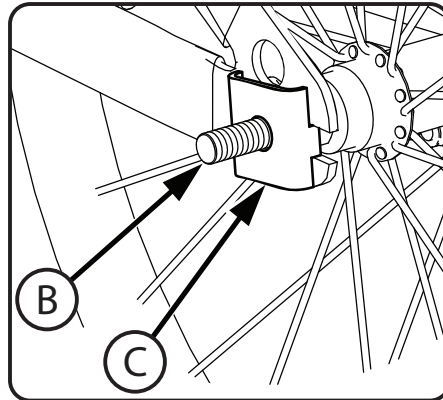

continued >>

## Training Wheels - continued

### Adjusting Training Wheel Height:

1. Make sure both Training Wheels are the same distance from the ground (1/8 in (3.17mm)) and pointing straight down.
2. Tighten Axle Nuts (A) securely.

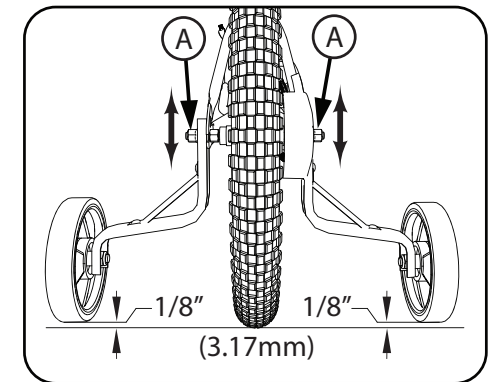

### EZ BUILD MODELS: Adjusting Training Wheel Height:

1. Remove Washer and Locknuts from Wheel Bolts (B).
2. Place Wheels and Bolts in proper Adjustment Hole (C) so that both Training Wheels are the same distance from the ground (1/8 in (3.17mm)) and pointing straight down.
3. Reinstall and tighten Locknuts (B) securely.

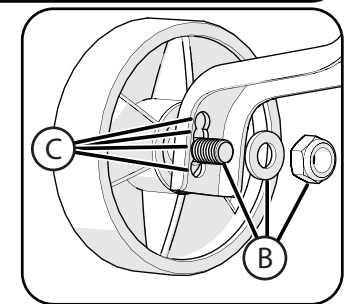

### OPERATION:

**WARNING:** Before each ride, make sure both axle nuts are tight. Also make sure both training wheels are the same distance from the ground.

As your child's ability improves, you may raise and eventually remove the training wheels. Raising the training wheels little by little will help them learn to ride on the bike's two wheels.

- **To move the training wheels,** loosen the axle nuts, slide the leg to the correct position, and retighten the axle nuts.
- **To remove the training wheels,** remove the Axle Nuts and Training Wheel Legs. Then reinstall Axle Nut over Alignment Tab and tighten securely.

**WARNING:** Failure to reinstall Axle Nuts can cause injury to the rider or to others.

**WARNING:** When riding with training wheels:

- Ride only on level areas.
- Do not ride on steep hills, uneven sidewalks, or near steps. The bicycle can tip over if a training wheel goes off the edge of the riding surface.
- Ride straight up and down sloped surfaces, because the bicycle can tip over when riding across sloped surfaces.
- Slow down at corners because you can not turn as quickly as bicycles without training wheels.