

anko

User Manual

Bluetooth® keyboard tab stand

42706632



Notice :

Please read user manual carefully before any operations, and keep it for your records.

Safety instructions and Keyboard maintenance

- Do not disassemble this product.
- Do not use the device in a damp environment. Clean the device with a dry cloth.
- Please keep the keyboard away from liquid or humid environment, saunas, swimming pool, steam room and don't let the keyboard get wet in the rain.
- Please don't expose the keyboard at too high or too low temperature condition.
- Please don't put keyboard under sun for a long time.
- Please don't put keyboard close to the flame, such as cooking stoves, candles or fireplace.
- Avoid sharp objects scratching products, timely to recharge products to ensure the normal use

Package includes:

- 1×Bluetooth® keyboard
- 1×USB cable
- 1×User Manual

FUNCTION PANELS

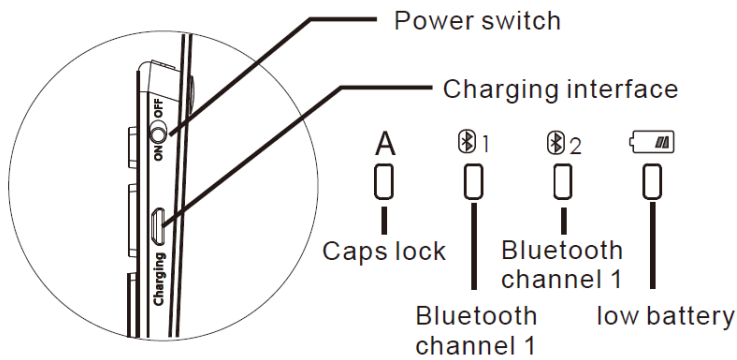
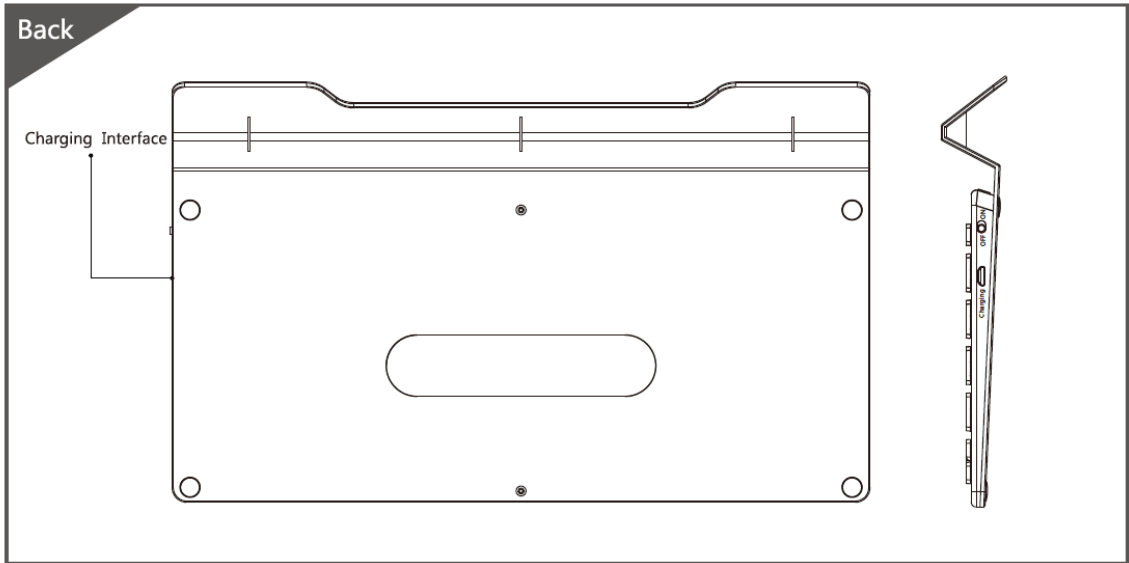
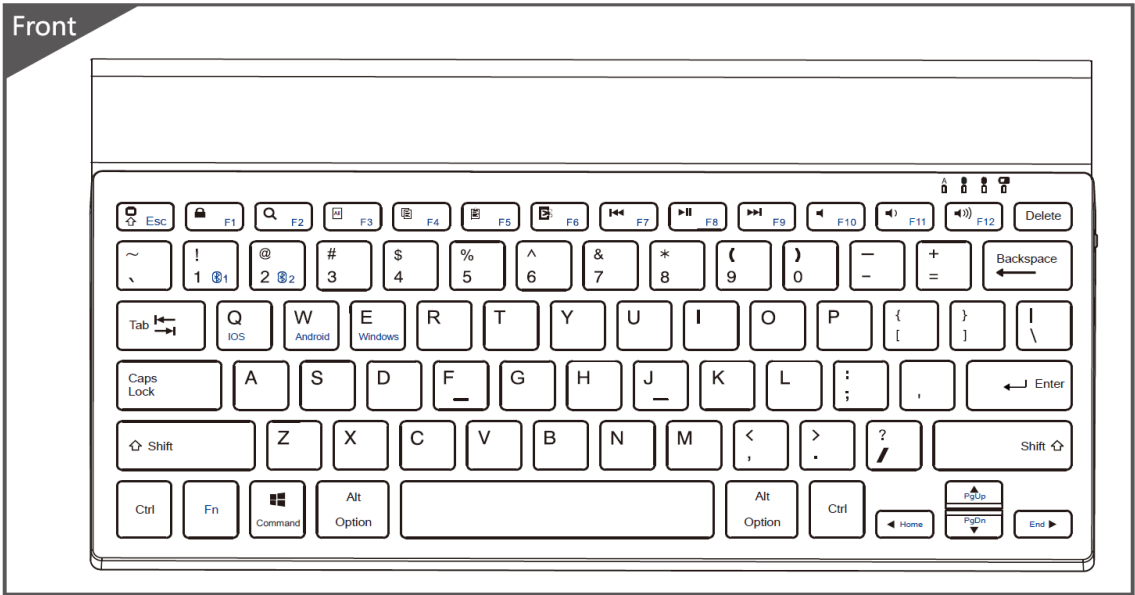

General Operation



Charging:

- The keyboard is powered via an integrated rechargeable battery. The battery cannot be removed or replaced.
- Upon initial use, the battery should be charged fully to ensure optimal performance and battery life.
- Charge the device with the included USB Cable.
- Plug the micro USB cable end to a DC 5V USB charger or a computer USB port
- Charging indicator light will be turn Red during charging. After fully charging, Red light goes off
- Charging time approx. 3 hours, when connected to a standard USB port.









Power On/Off

1. To turn the unit on, turn the Power On/OFF switch to ON. The blue LED will light up.
2. To turn the unit off, turn the Power On/OFF switch to OFF. The LED will go off.

Pairing a Bluetooth device for the first time

1. Turn the unit on, the Bluetooth channel 1 will light up.
2. Press “ + ” key 3s, the blue light twinkle; The keyboard is in paring mode.
3. On your tablet or smartphone, make sure the Bluetooth is on. Select Setting > Bluetooth > on.
4. Search the Bluetooth keyboard name ‘KM42706632’ in your Bluetooth settings menu and select pair.
5. If your table or smartphone request to enter a PIN code. Use the Bluetooth keycode to enter the PIN follow on screen.
6. After pairing success, the blue led light will go off.







































****This Bluetooth keyboard can be connected to additional Bluetooth device by channel 2. Only one device can connect the Bluetooth keyboard at the same time. Follow the below step to switch between two Bluetooth devices.**

7. When you want connect two device on the keyboard, Press  +  at the same time, the channel 2 light on, then press  +  3s, green light twinkle; The keyboard is in paring mode. Repeat steps 3 to 5 to pair with second device via channel 2.
8. You can switch the Bluetooth devices by  +  or  + .

NOTE: Should your device become unpaired or you are not able to connect it, repeat the above steps.

Function key mapping for iOS / Android and Windows

1. To use the function key, Press Fn+iOS or Fn+Android or Fn+Windows to switch for the operation system before use.
2. For Windows user using the F1 to F12 function keys. Press “Fn+F1” at the same time to use the function keys.

IOS		Android		Windows	
Fn+ IOS	Corresponding function	Fn+ Android	Corresponding function	Fn+ Windows	Corresponding function
	Return to Desk		Home		Esc
	lock screen		lock screen		F1
	Search		Search		F2
	Select		Select		F3
	Copy		Copy		F4
	Stick		Stick		F5
	Cut		Cut		F6
	Pre-Tracke		Pre-Track		F7
	Play/Paus		Play/Pause		F8
	Next		Next		F9
	Mute		Mute		F10
	Volume-		Volume-		F11
	Volume+		Volume+		F12

Technical Specifications

Working distance :8m~10m

Bluetooth version: 3.0

Build-in Rechargeable battery

Charging time up to 3 hours

Input: DC 5V / 200mA

Sleep mode: 10 minutes

12 Month Warranty

Thank you for your purchase from Kmart.

Kmart Australia Ltd warrants your new product to be free from defects in materials and workmanship for the period stated above, from the date of purchase, provided that the product is used in accordance with accompanying recommendations or instructions where provided. This warranty is in addition to your rights under the Australian Consumer Law.

Kmart will provide you with your choice of a refund, repair or exchange (where possible) for this product if it becomes defective within the warranty period. Kmart will bear the reasonable expense of claiming the warranty. This warranty will no longer apply where the defect is a result of alteration, accident, misuse, abuse or neglect.

Please retain your receipt as proof of purchase and contact our Customer Service Centre on 1800 124 125 (Australia) or 0800 945 995 (New Zealand) or alternatively, via Customer Help at Kmart.com.au for any difficulties with your product. Warranty claims and claims for expense incurred in returning this product can be addressed to our Customer Service Centre at 690 Springvale Rd, Mulgrave Vic 3170.

Our goods come with guarantees that cannot be excluded under the Australian Consumer Law. You are entitled to a replacement or refund for a major failure and compensation for any other reasonably foreseeable loss or damage. You are also entitled to have the goods repaired or replaced if the goods fail to be of acceptable quality and the failure does not amount to a major failure.

For New Zealand customers, this warranty is in addition to statutory rights observed under New Zealand legislation