

# anko

0+  
months

## NEWBORN STROLLER INSTRUCTION MANUAL

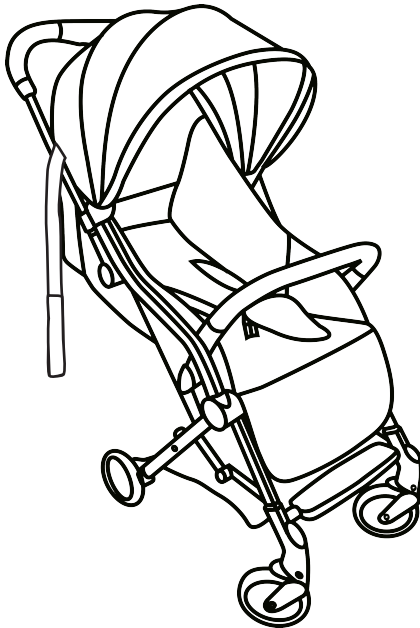

**IMPORTANT:  
RETAIN FOR FUTURE REFERENCE  
READ CAREFULLY**

# 1 Safety Notes

---

## CAUTION:

Read these instructions carefully before assembly and use and keep for future reference. The child may be hurt if you do not follow these instructions.

## WARNING: TO AVOID INJURY OR DEATH

- FOLLOW THE MANUFACTURER'S INSTRUCTIONS AT ALL TIMES.
- ALWAYS APPLY THE BRAKES WHENEVER THE STROLLER IS STATIONARY.
- SECURE THE CHILD IN THE HARNESS AT ALL TIMES.
- PUT ON ALL THE BRAKES WHENEVER YOU PARK THE STROLLER.
- DO NOT LEAVE CHILDREN UNATTENDED.
- DO NOT CARRY EXTRA CHILDREN OR BAGS ON THIS STROLLER.
- MAKE SURE CHILDREN ARE CLEAR OF ANY MOVING PARTS IF YOU ADJUST THE STROLLER, OTHERWISE THEY MAY BE INJURED.
- Please ensure that the safety harness is adjusted and used at all times.
- A harness can form loops that may be a strangulation hazard. Never leave harness straps connected when not fitted to a child in the stroller.
- Check the stroller is fully erected and all safety locks are engaged before placing a child in the stroller, otherwise they may be injured.
- Do not attempt to carry the stroller with your child in it.
- The weight of the children using this stroller should not exceed 15 kg.
- The stroller is not suitable for running or skating.
- Check the storage latch is engaged before you lift and carry the stroller.
- Do not allow children to stand on the product.
- Do not use the stroller near an open fire, barbecue, or exposed flame.
- Use only those accessories which are supplied by the manufacturer, and approved for use with the stroller.
- Any goods carried in the basket are not to exceed 2 kg.
- Avoid placing stroller on parquet, linoleum or carpet floors as wheels may cause stains.
- The stroller is designed for use on flat and gently sloping surfaces and maybe unstable on higher sloping and uneven surfaces. Extra care is needed on steep slopes to prevent the stroller tipping over.
- Care shall be taken if the stroller is used on stairs or escalators.

# 1 Safety Notes

---

- Do not leave your child exposed to the sun. The canopy or hood on this product will not give your child total protection from the harmful rays of the sun.
- Take care when unpacking and during assembly.
- Dispose of all packing materials carefully after assembly.
- Any additional or replacement parts should only be obtained from the manufacturer or distributor.
- Never substitute parts.

## 2 Parts List

---

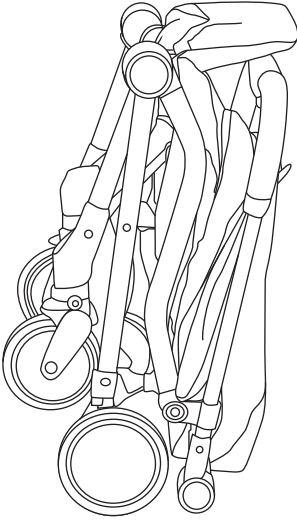

**A x 1**  
stroller



**B x 1**  
bumper bar

### 3 Unfolding

Unpack all contents and check that all parts are present before starting assembly. Please refer to the parts list.

1. Located on the stroller (A) handle, slide the folding button across.
2. At the same time, push up the safety lock.
3. And lift up the stroller handle to open.

#### **WARNING:**

- DUE CARE SHOULD BE EXERCISED WHEN FOLDING, UNFOLDING, OR ADJUSTING THE STROLLER TO PREVENT FINGER/BODY PART ENTRAPMENT OR PINCHING.
- KEEP CHILDREN AWAY FROM STROLLER WHEN FOLDING OR UNFOLDING.
- ENSURE THE FRAME LOCK IS FULLY ENGAGED BEFORE PLACING CHILD IN THE STROLLER.

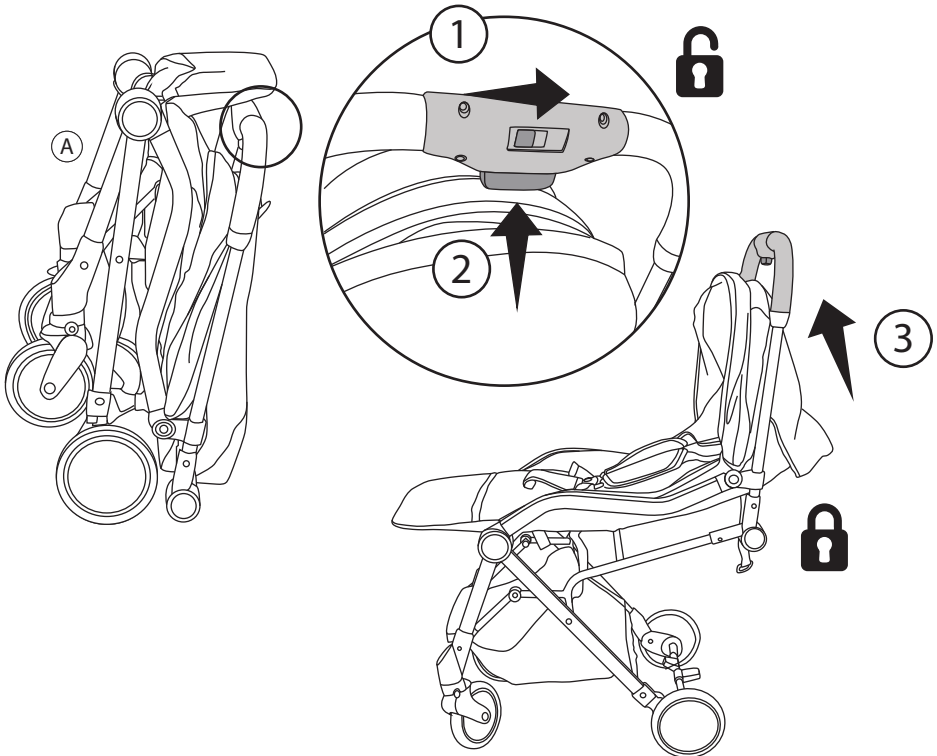

## 4 Bumper Bar Assembly

---

1. Insert the ends of the bumper bar (B) into the attachment points on the stroller frame.
2. Wait to hear them 'click' into position.  
Lift gently to ensure the bumper bar is locked into place.

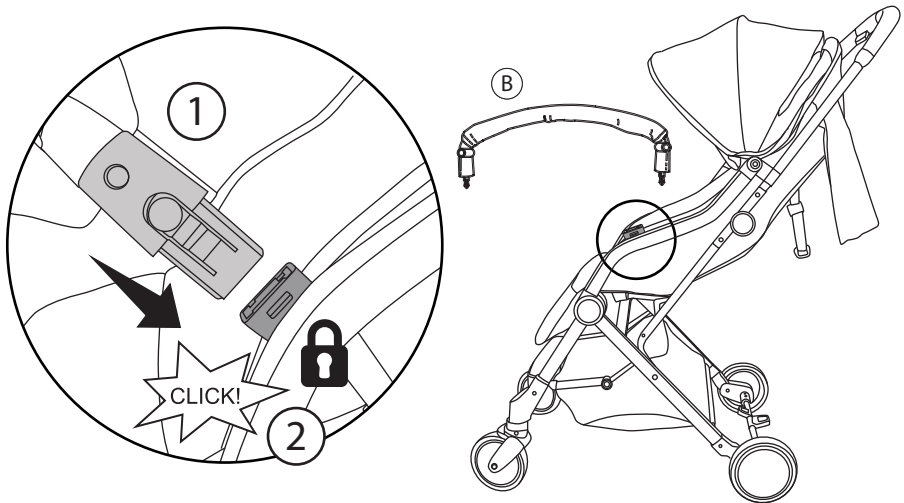

3. Press buttons located either side of the bumper bar housing.
4. Lift to remove bumper bar from stroller.

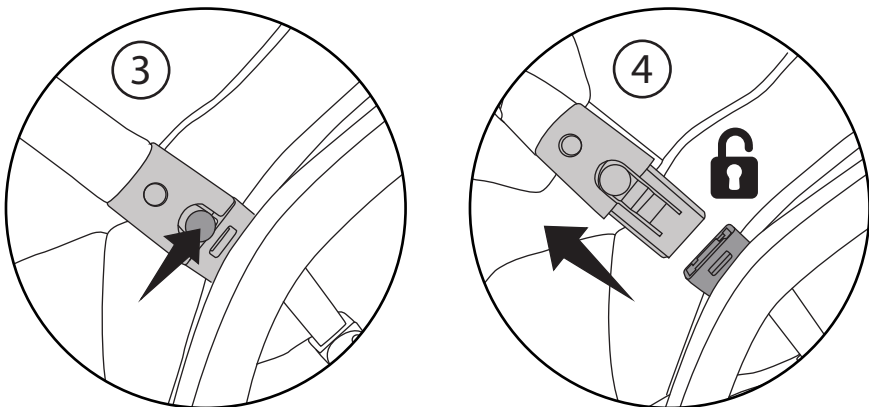

## 5 Backrest Adjustment

---

1. Locate the backrest adjustment mechanism at the rear of the seat. Squeeze the clip on the webbing strap.
2. Slide the clip up or down the webbing strap to gently pull up or lower the backrest. Release the clip at desired backrest recline.

### **WARNING:**

- ALWAYS ENSURE THAT THE SEAT IS SECURELY FIXED IN POSITION BEFORE USE.
- DO NOT ADJUST THE BACKREST WHILE YOUR CHILD IS IN THE STROLLER.

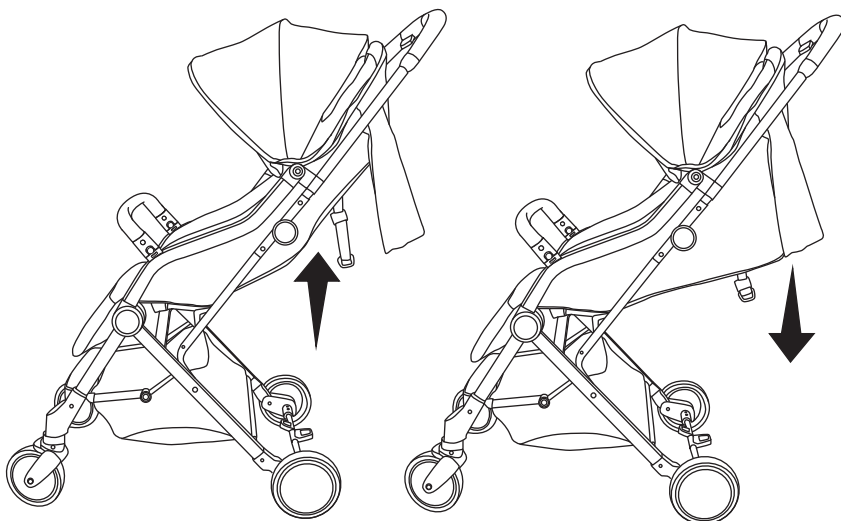
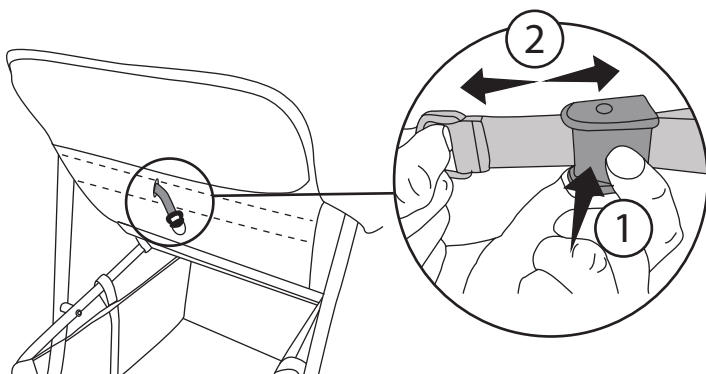

## 6 Canopy

---

1. The canopy can be opened or closed by pulling forward or backward on the canopy rim.
2. Release the toggle to extend canopy with mesh air vent.

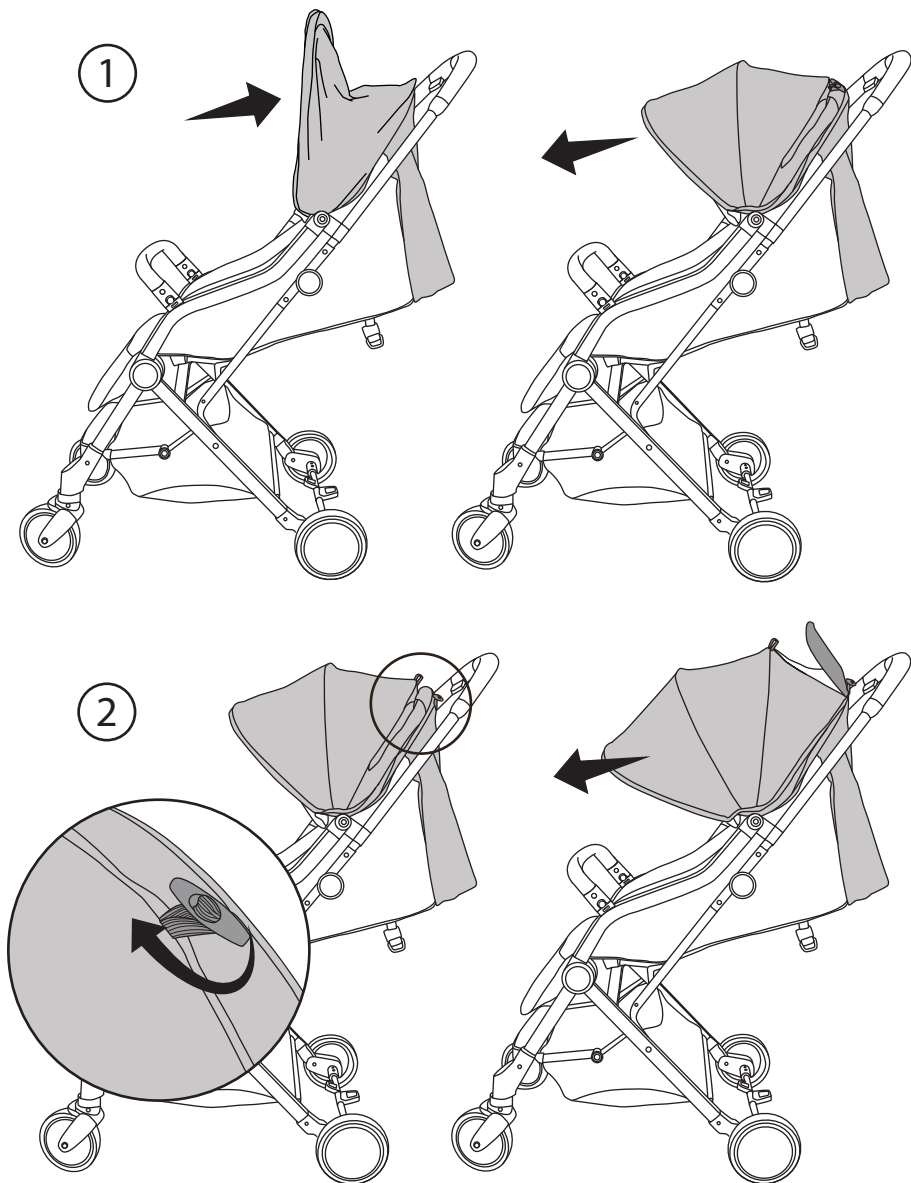



# 7 Brakes

---

To engage the brake, push down brake locking pedal. Lift up pedal to release brake. The brake will 'click' when locked into position.

## WARNING:

- ALWAYS APPLY THE BRAKE WHENEVER THE STROLLER IS STATIONARY.
- ENSURE THE BRAKE IS ENGAGED DURING THE LOADING AND UNLOADING OF CHILDREN.

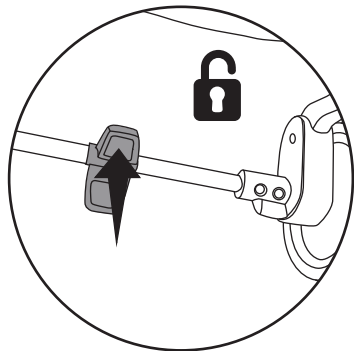
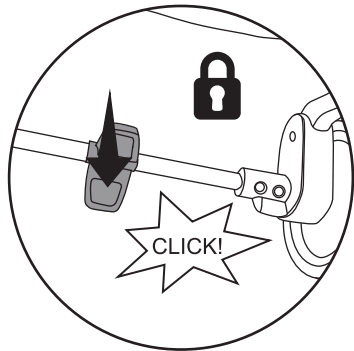
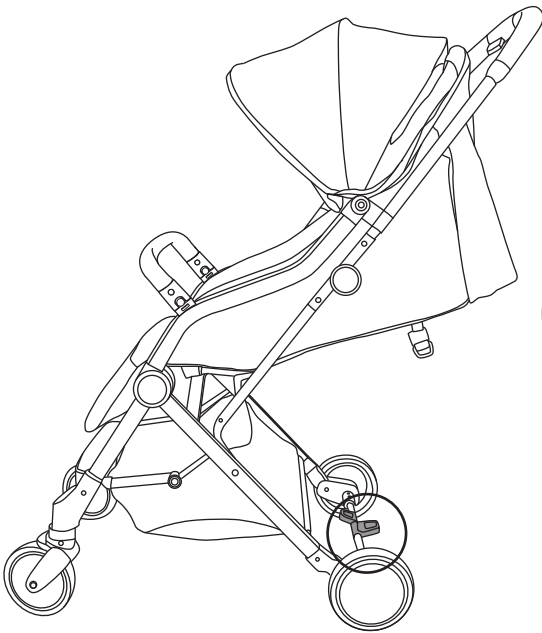

# 8 Harness Operation

---

1. Insert all buckle clips into the buckle housing until they engage securely in place. Listen for the 'click'.

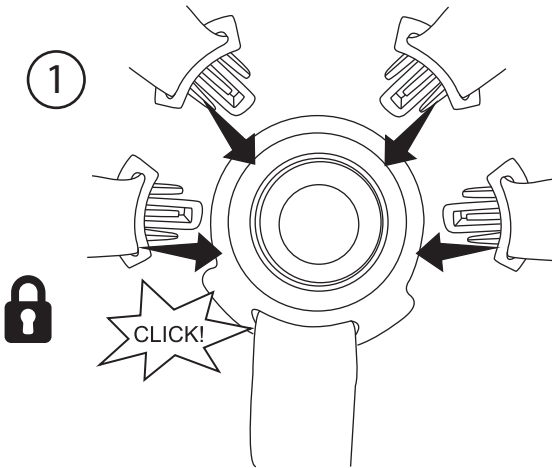

2. Press the centre button to release child from harness.

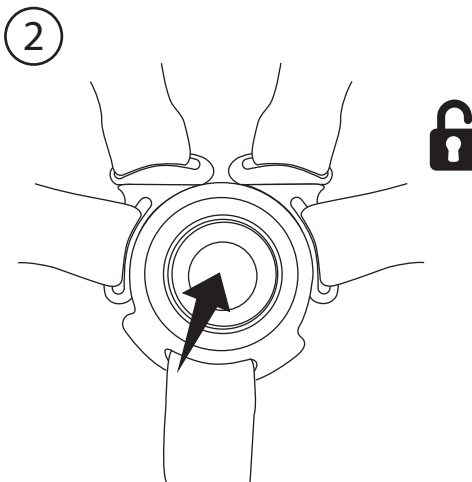

## 8 Harness Operation

3. Adjust slider to ensure a snug fit for your child. Repeat for all straps. After making adjustments to the seat always readjust the harness.

4. The stroller has 3 shoulder height positions.

Undo the harness and remove the shoulder pads to adjust the shoulder height. Remove harness strap from webbing holders. Redo harness.

CAUTION: Always adjust the harness when changing the seating position of the child.

### WARNING:

- USE THIS HARNESS AT ALL TIMES.
- HARNESS CAN FORM LOOPS WHICH MAY POSE A STRANGULATION HAZARD. NEVER LEAVE THE HARNESS CONNECTED WHEN NOT FITTED TO A CHILD IN THE STROLLER.

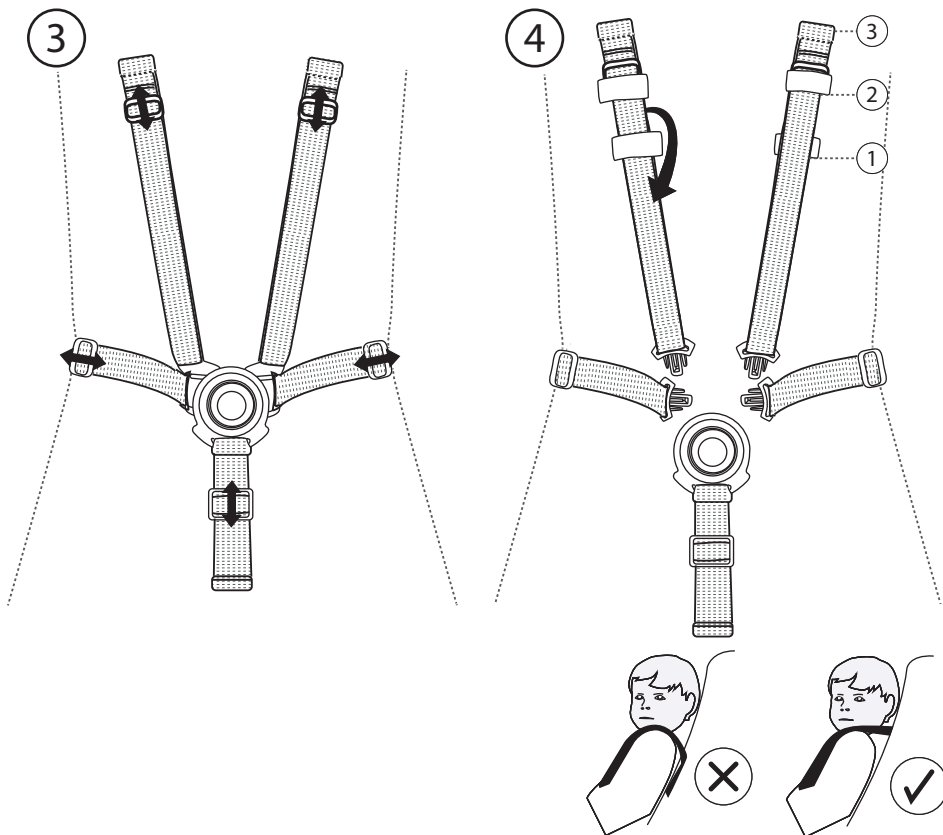

## 9 Tether Strap

---

The stroller includes a tether strap for your child's safety.

Slide your hand through the tether strap loop whenever you use the stroller. Only remove your hand from the tether strap loop when brake has been applied to the stroller wheels.

### **WARNING:**

- **USE THE TETHER STRAP TO STOP THE STROLLER ROLLING AWAY.**

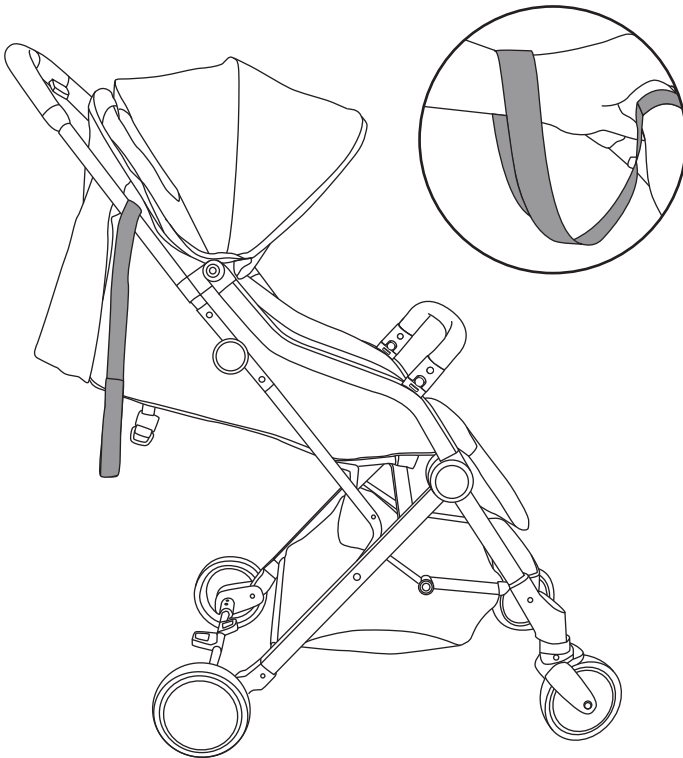

# 10 Footrest Adjustment

---

1. Locate the adjustment levers either side of the footrest. Pull levers towards you.
2. Adjust to the required position.

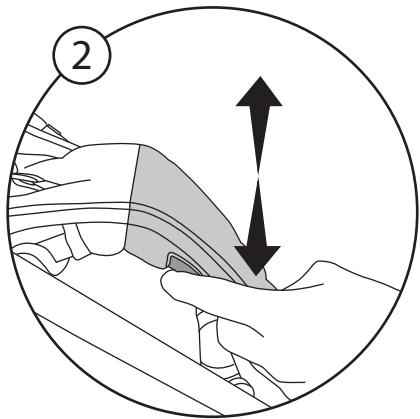
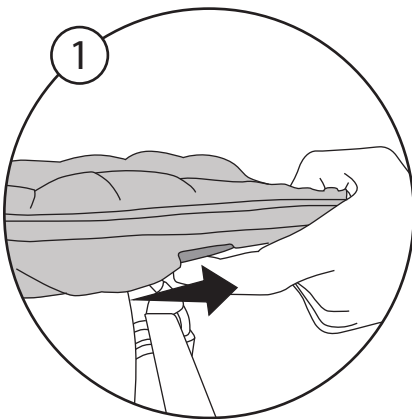
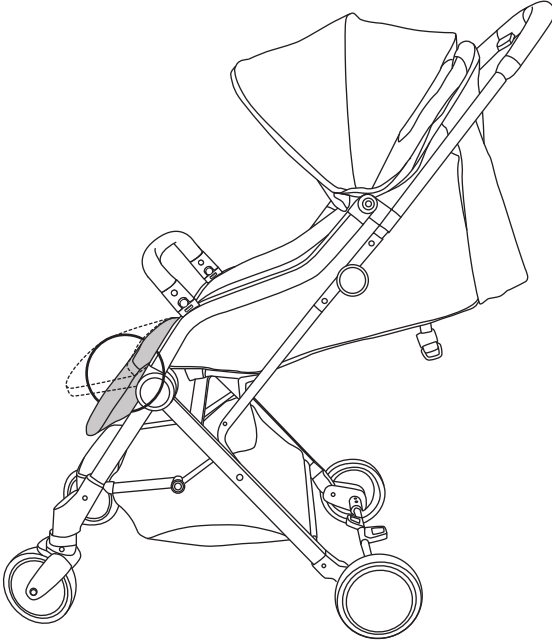

# 11 Folding

1. Engage the brake.
2. Fold the canopy.
3. Slide the folding button across.
4. At the same time, push up the safety lock.
5. And push the stroller handle down until the lock engages with a 'click'.

Note: the bumper bar folds automatically when the stroller is folded.

## WARNING:

- DUE CARE SHOULD BE EXERCISED WHEN FOLDING, UNFOLDING, OR ADJUSTING THE STROLLER TO PREVENT FINGER/BODY PART ENTRAPMENT OR PINCHING.
- KEEP CHILDREN AWAY FROM STROLLER WHEN FOLDING OR UNFOLDING.

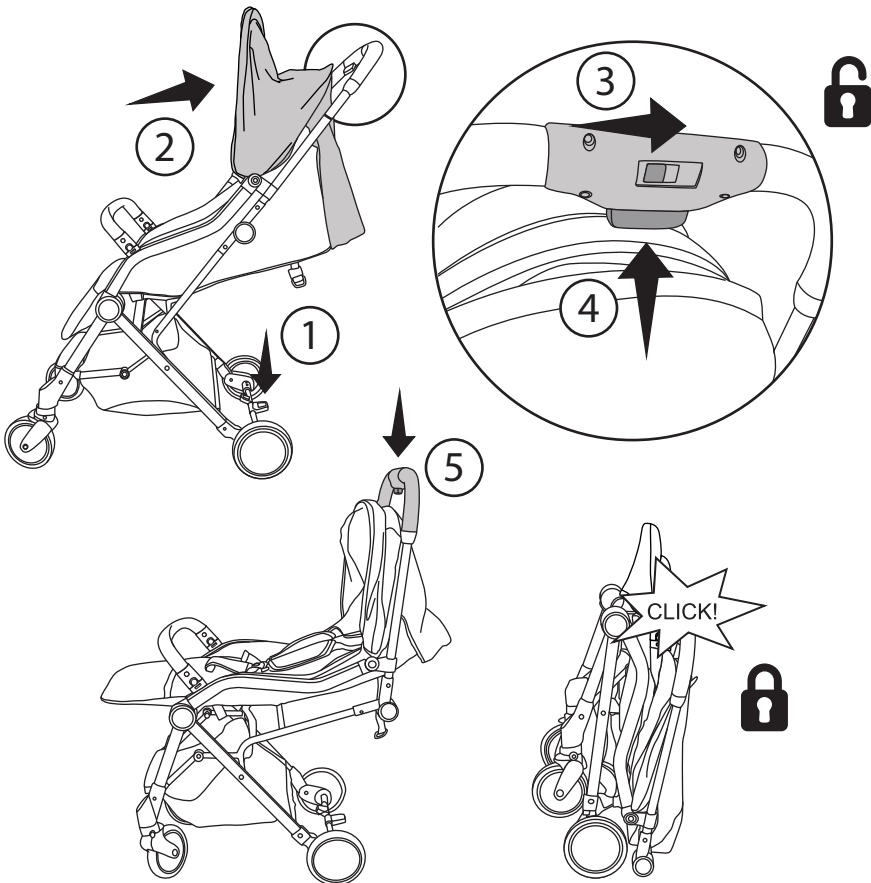

# 12 Care

---

## **Maintenance**

- Always store in a clean and dry place.
- Occasionally clean and lubricate wheels and axles with light lubricating oil.
- Inspect the product before assembly and periodically during use. Never use this product if there are any loose or missing fasteners, joints or broken parts.

## **Cleaning**

- Plastic and metal parts may be sponged lightly using warm water and a mild detergent.
- Dry thoroughly before storing.
- Removable and non-removable fabric covers may be hand washed or spot cleaned. Use mild soap or upholstery shampoo. Wash separately. Do not bleach. Dry in shade thoroughly before re-use and avoid direct heat and sunlight. Do not iron. Do not dry clean ☒.
- Do not use abrasive pads, bleach or strong detergents.

IMAGES/ DRAWINGS IN THE MANUAL ARE FOR VISUAL PURPOSES ONLY. ACTUAL PRODUCT MAY VARY SLIGHTLY. THE MANUFACTURER RESERVES THE RIGHT TO CHANGE ANY SPECIFICATION OR FEATURE WITHOUT PRIOR NOTICE.

Keycode: 42712923

MADE IN CHINA

©KMART AUSTRALIA LIMITED

ANKO, KIDS&CO. AND BABY SOLUTIONS® ARE ALL TRADEMARKS OF KMART AUSTRALIA LIMITED. THEY ARE USED IN NEW ZEALAND BY KMART NZ HOLDINGS LIMITED TRADING AS KMART IN NEW ZEALAND.

KMART AUSTRALIA - 690 SPRINGVALE RD, MULGRAVE, VIC 3170 AUSTRALIA.

KMART NEW ZEALAND - REGIONAL OFFICE C/O KMART PAPATOETOE STORE HUNTERS PLAZA, GREAT SOUTH RD, PAPATOETOE, AUCKLAND, NEW ZEALAND.