

anko

Rechargeable Hand - Stick Vac For Household Use Only



Model No.: EV-693-S296
Rev 1

Note: The specifications and/or components of this appliance are subject to change without prior notice.

If any Accessories should fail during use, please call 1300 105 888 (Australia) or 09 8870 447 (New Zealand) for an immediate replacement. This will save you from returning the product to the store.

If we can assist you in any other way, please feel free to contact us

1	Warnings	4
2	Safety Directions	4
3	Transporting your Vacuum	7
4	Components	7
5	Assembly Method	8
	5.1 Charging / Storage Stand	8
	5.2 Assembling the Extension Tube	10
	5.3 Removing the Extension Tube	10
	5.4 Attaching the Motorised Floor Head	10
	5.5 Removing the Motorised Floor Head	11
	5.6 Using Without the Extension Tube	11
	5.7 Tools and Tool Storage	11
	5.8 Charging	13
6	Using the Vacuum Cleaner	14
	6.1 On / Off	14
	6.2 Speed Control	15
7	Indicator Lights	15
	7.1 Charge Status	15
8	Emptying the Dust Canister	15
9	User Maintenance	17
	9.1 Cleaning the Filters	17
	9.2 Cleaning Dust Canister	19
	9.3 Cleaning the Vacuum Cleaner Body and Tools	19
	9.4 Cleaning the Motorised Floor Head	20
10	Storage	21
11	Troubleshooting	22
13	Warranty Against Defect	23

1 Warnings

Before using this appliance, read and follow all warnings and instructions in this manual, even if you are familiar with this product.

This appliance is not intended for use by persons (including children) with reduced physical, sensory or mental capabilities, or lack of experience and knowledge, unless they have been given supervision or instruction concerning use of the appliance by a person responsible for their safety.

Children should be supervised to ensure that they do not play with the appliance.

2 Safety Directions



Please read this instruction manual carefully before first use. It is advisable to keep this instruction manual for future reference.

DO NOT vacuum water, wet objects, liquids, ashes, hot coals, cigarette butts, matches or any hot, smoking or burning objects, etc.

DO NOT pick up flammable or combustible materials (i.e. lighter fluid, petrol, kerosene, etc.) or use in the presence of explosive liquids or vapour.

DO NOT pick up toxic material (i.e. chlorine bleach, ammonia, drain cleaner, etc.)

DO NOT vacuum Toner (for laser printer, copy machines etc.) as there is a risk of fire and explosion.

DO NOT vacuum plaster dust, cement dust etc. as the filter will block very quick.

DO NOT use the vacuum without the filter fitted.

DO NOT store or use the appliance near high temperature areas.

DO NOT run over the charger cable with the vacuum cleaner.

DO NOT use the vacuum cleaner if it is blocked. Turn off and clear all blockages before continuing.

DO NOT use the vacuum cleaner with a blocked filter. Clean filter before continuing. (refer to User Maintenance section).

DO NOT use the vacuum cleaner if the appliance malfunctions, abnormal noise, smell, smoke, is dropped or damaged in any manner or any breakage is found during operation.

For electrical safety, any repairs to the product must be performed by a qualified electrical person only, or the product must be disposed of.

DO NOT misuse the Charger Cable. Never pull the appliance by the cable or pull to disconnect it from the outlet. Instead, grasp the charger body and pull to disconnect.

DO NOT use the vacuum cleaner to pick up large objects, hard or sharp objects such as glass, nails, screws, coins, etc. that are likely to cause damage.

DO NOT use with damaged Charger Cable or Charger Body.

DO NOT use vacuum cleaner if it has been dropped, damaged, left outdoors, or dropped into liquid (water etc.)

DO NOT handle Charger or vacuum cleaner with wet hands.

DO NOT put any objects into openings.

DO NOT use with any openings blocked and do not restrict airflow.

DO NOT use without the filter in place.

DO NOT attempt to modify this product in any way.

DO empty the Dust Canister regularly for optimal operation of the vacuum.

DO keep hair, loose clothing, fingers, feet and body parts away from openings or moving parts.

DO disconnect the Charger from the power supply when not in use,

DO use only on dry, indoor surfaces.

DO use only as described in this manual. Use only manufacturer's recommended attachments.

DO Keep Charger Cable away from heated surfaces.

DO Keep all openings free of dust, lint, hair, and anything that may reduce airflow.

DO use extra care when vacuuming on stairs.

DO keep your work area well lit.

DO store your appliance indoors in a cool dry area.

DO ensure children and babies cannot play with plastic bags or any packaging materials.

DO operate the Charger from a power source of the same voltage, frequency and rating as indicated on the product identification plate.



WARNING

Only use the Battery Charger which was supplied with this appliance.
Model No. ZD024D350050AU 100–240V~ 50-60Hz 0.5A Output: 35.0V--- 500mA

Battery Pack Specification: EV-693-S296-22

Type: Li-ion, 29.6Vd.c., 2200mAh

Consumers are cautioned against using and/or purchasing counterfeit and/or inferior quality batteries. These batteries have the potential to cause fire, personal injury, and/or damage to property. These batteries are typically found on online-auction websites or from other retailers and are known to pose a potential safety risk.

Never try to recharge Non-Rechargeable batteries as they may explode, catch on fire or cause personal injury and/or damage to property.

- May explode if disposed of in fire.
- To prevent injury or burns, do not allow metal objects to contact battery terminals.
- Do not use or store in temperatures above 40°C



The Battery Pack must be removed from the vacuum cleaner before disposal.

Contact your local waste management authority for more information on Battery Recycling and disposal regulations in your area.



This symbol on the product or its packaging indicates:

Do not dispose of electrical appliances or batteries as unsorted municipal waste, use separate collection facilities. Contact your local council for information regarding the collection systems available. If electrical appliances are disposed of in landfills or dumps, hazardous substances can leak into the groundwater and get into the food chain, damaging your health and well-being. Please contact your local council or regional authority for more information on collection, reuse, and recycling programmes.

If this appliance is used by a third party, **DO** supply the instruction manual with it.

No liability can be accepted for any damage caused by non-compliance with these instructions or any other improper use or mishandling of appliance.

This product has not been designed for any uses other than those specified in this manual.

ONLY for domestic use. Industrial or commercial use invalidates the warranty.

Read and Save These Instructions

3 Transporting your Vacuum

To move your vacuum cleaner from room to room, unplug the unit and carry using the carry handle.

Never pull or carry the vacuum cleaner by its Charger cable.

Never carry the vacuum cleaner by the accessories / Tools.

4 Components

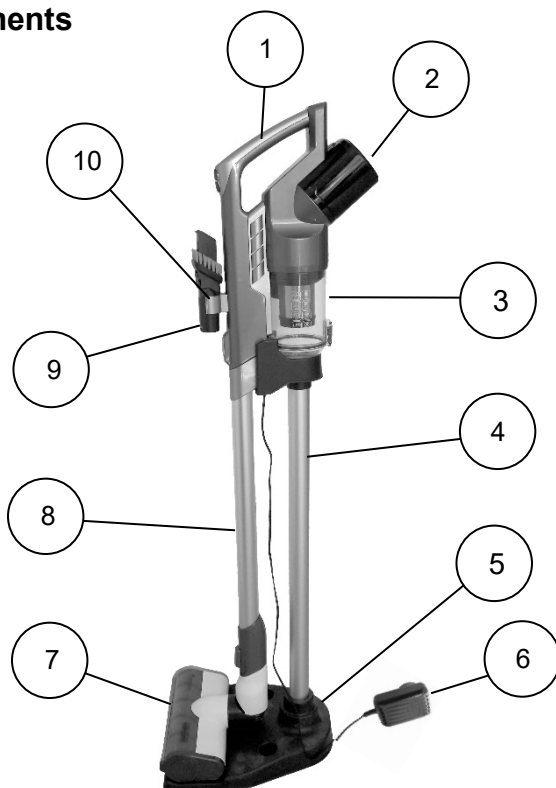

1	Stick Vac Body / Handle	6	Battery Charger
2	Rechargeable / Removable Battery Pack	7	Motorised Floor Head
3	Dust Canister	8	Extension Tube
4	Stand	9	Crevice / Brush Tool
5	Base	10	Tool Holder

Note: The specifications and/or components of this appliance are subject to change without prior notice

5 Assembly Method

Please Note: Always remove the Battery Charger from the power socket before assembly.

5.1 Charging / Storage Stand

The vacuum cleaner is supplied with a Charging / Storage stand and will need to be assembled before use.

Place the base on a flat surface and take the stand post and insert one end into the hole in the base as shown.

NOTE: The end of the tube has a slot cut out in it which needs to align with the tab inside the base hole.

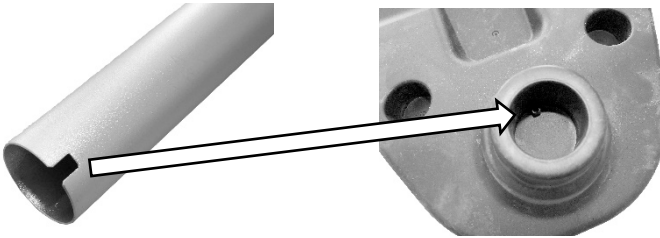

Once the slot is aligned, firmly push the tube inside the base hole until it is fully inserted.

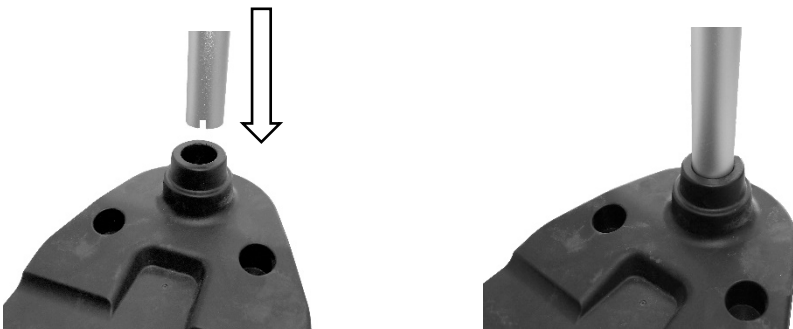

Next, take the stand head unit (with the battery charger attached) and place over the top of the tube.

NOTE: The end of the tube has a slot cut out in it which needs to align with the tab inside the head unit hole. (with the charger cable towards the front as shown below)



Once the slot is aligned, firmly push the head unit down onto the tube until it is fully inserted.



The Charging / Storage Stand is now ready.

5.2 Assembling the Extension Tube

Insert the end of the Extension Tube into the mating hole ensuring the locking tab is aligned, then push inward until it locks into place.

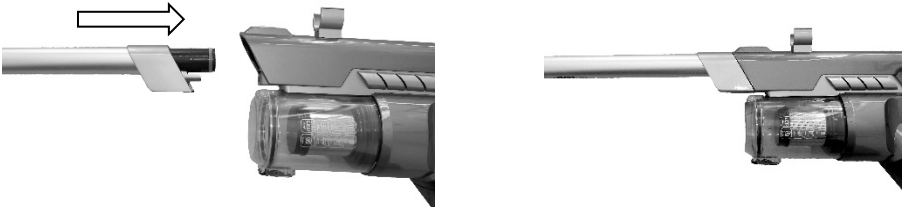

5.3 Removing the Extension Tube

To remove the Extension Tube, grasp the Tube, press the locking tab down to release then pull the hose straight out.

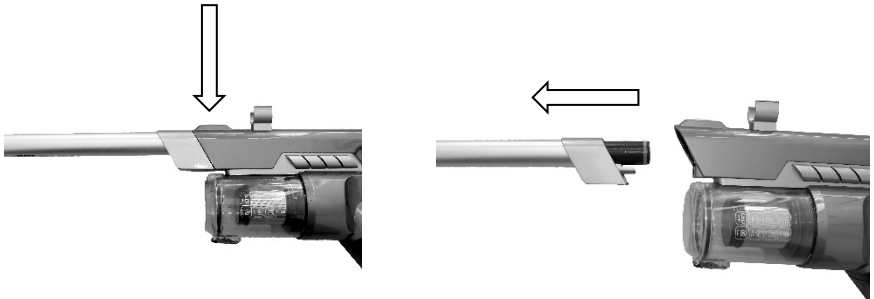

5.4 Attaching the Motorised Floor Head

To attach the motorised floor head to the other end of the extension tube, insert the end of the Extension Tube into the end of the Floor Head, ensuring the locking tab is aligned, then push inward until it locks into place.

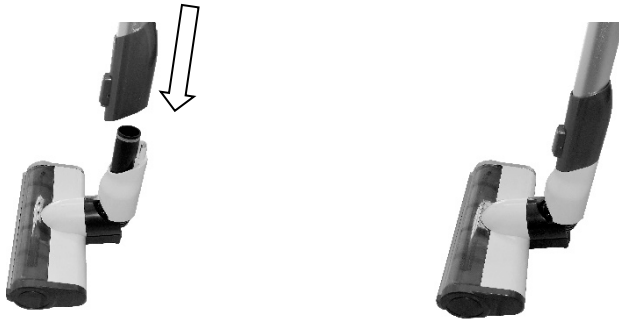

5.5 Removing the Motorised Floor Head

To remove the Motorised Floor Head, grasp the Motorised Floor Head, press the locking tab inward to release, then pull the Tube straight up and out.



5.6 Using Without the Extension Tube.

The vacuum cleaner can be used without the extension tube by attaching the Accessories and Motorised Floor Head directly to the vacuum cleaner.

To attached and remove, follow the same steps as if using the Extension tube.

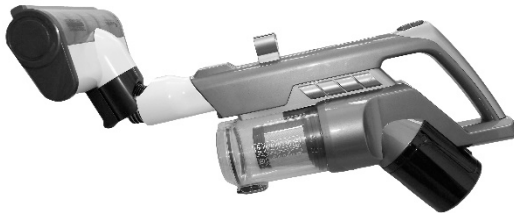

5.7 Tools and Tool Storage

Crevice / Brush Tool

Crevice / Brush tool is for cleaning furniture and into corners etc.

To use the Brush tool, press the release button to unlatch and slide the brush down until it locks in place.

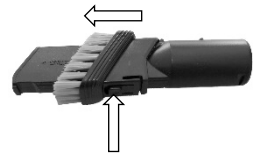

To use the Crevice tool, press the release button to unlatch and slide the brush up until it locks in place

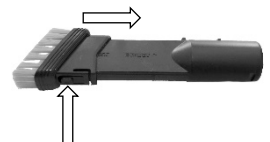

To fit the tool, line up with the end of the hand vac and push in.



Note: The tool can also be used on the end of the Extension Tube.

To remove, press the locking tab down to release and then pull the tool straight out.

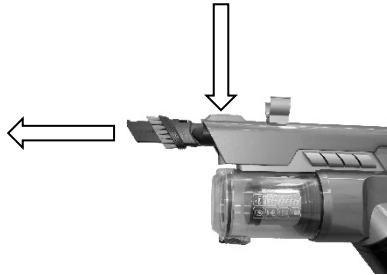

Tool Holder. Located on front of Vacuum Cleaner Body.

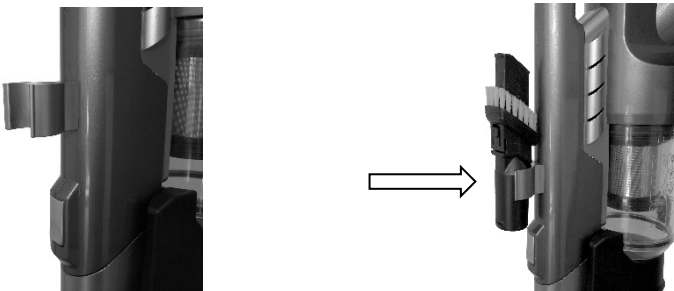

Attach the Tool by pushing it into the clamp as shown.

To remove, grasp the tool and pull straight out.

5.8 Charging

Note: Charge the Vacuum Cleaner for at least 5 hours prior to use.

Only use the Battery Charger which was supplied with this appliance.

Insert the battery into the back of the vacuum Cleaner body and push all the way in until it locks in place.

Note: The Battery can only be inserted in one direction as shown

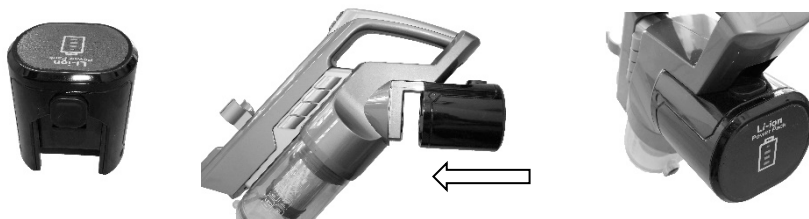

To Remove the battery, press the release button located on top of the battery, and the battery will be released.



Place the vacuum cleaner onto its Charger Stand and push down ensuring it is seated properly.

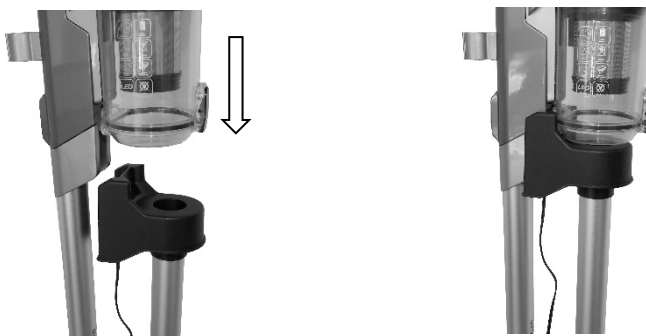

Plug the Battery Charger into the power point and switch on.

During Charging, the indicator light bars on the back of the battery will illuminate in a rolling fashion indicating the battery is charging.

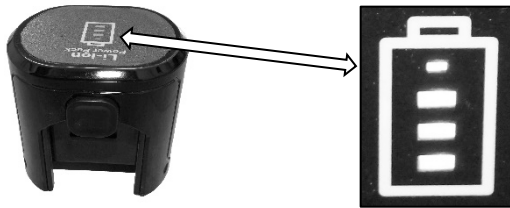

All the bars will be illuminated and be steady when fully charged.

When the battery is fully charged, switch off and unplug the battery charger from the power supply.

When fully charged, the Vacuum Cleaner is ready for use.

NOTE: NEVER BLOCK ANY VENTS OR OPENINGS.

6 Using the Vacuum Cleaner

6.1 On / Off

To use the Vacuum Cleaner, assemble the unit as previously instructed and ensure the battery is fully charged.

When the High-Speed setting is selected, the fully charged battery will provide approximately 15 minutes of power for continuous use of the vacuum cleaner.

When the Low-Speed setting is selected, the fully charged battery will provide approximately 55 minutes of power for continuous use of the vacuum cleaner.

To switch on, press the top button on the handle once. The vacuum cleaner will start in low power mode.

Press the same button again to turn Off.

Note: The vacuum cleaner cannot be started when on the charging stand.



6.2 Speed Control

Whilst the vacuum cleaner is running, press the lower button on the handle once. The vacuum cleaner will change to high power mode.



Press the same button again and it will change back to low power mode.

Press the On / Off button to turn Off.

7 Indicator Lights

7.1 Charge Status

Refer to the section “Charging” for the indicator light function during charging.



As the battery charge is used, the illuminated indicator lights will change from four bars to three to two, two to one.

When it reaches the “one” light, it will flash indication the battery needs recharging.

The vacuum cleaner will automatically turn off when the battery is flat and needs recharging.

8 Emptying the Dust Canister

To empty the dust canister, first remove the Dust Canister from the vacuum cleaner.

Grasp the dust canister body, and whilst holding the vacuum cleaner body, twist the dust canister clockwise (from looking down from the top) and pull down to remove it.



Take the dust canister to a dustbin.

Press the Trap Door release button inward to release the latch and the trap door will swing open emptying the contents into the bin.

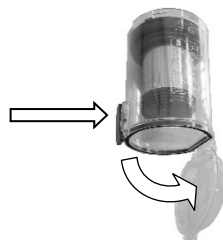

To close the trap door, close it manually until it clips shut.

Empty the Dust Canister as frequently as possible or when the suction power is reduced or after use for optimum performance.

Note: At the same time, you can brush the inside of the dust canister with a small brush or use water to wash Refer to section “Cleaning the Filter”.

To refit the Dust Canister into the vacuum cleaner, ensure the trap door release button is facing the outside and then push up into the vacuum cleaner.

Align the “Open Padlock” icon arrow on the side of the dust canister with the arrow on the vacuum cleaner body and then rotate the dust canister anticlockwise (from looking down from the top) until it locks in place and the “Closed Padlock” icon arrow on the side of the dust canister aligns with the arrow on the vacuum cleaner body as shown.

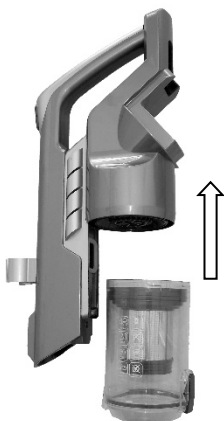

9 User Maintenance

WARNING: The battery must be removed from the vacuum cleaner before any maintenance, cleaning or replacement of parts.

NOTE: To maximise the performance of your vacuum cleaner, you should clean the filters regularly.

If the filter is broken or worn, replace it before continuing to use the vacuum.

A Filter can be purchased from our Customer Service. You can call our customer service number: 1300 105 888 (Australia) and 09 8870 447 (New Zealand), or via email info@hegroup.com.au

9.1 Cleaning the Filters

Important Note – The Filters must be cleaned regularly for the best suction performance and to prevent over-heating and damage to your vacuum cleaner.

Cleaning is best done at the same time when emptying the dust Canister after you have finish vacuuming for the day.

NOTE: Never use the vacuum cleaner with a wet or damp filter or without the filter fitted.

Using a wet or damp filter will damage the filter, may cause serious damage to the vacuum cleaner and will void your warranty.

Note: Only wash the white filter if it is very dirty, otherwise just tap the edge of the filter on a hard surface to dislodge any dust and debris.

To access the filters, first remove the dust canister from the vacuum cleaner body as described in the section “Emptying the Dust Canister”.

Grasp the handles of the filter and pull up and out to remove.



Next, disassemble the filters into their separate components for cleaning.

Grasp the two handles of the filter and rotate anticlockwise to unlock.

Pull up and out to separate.



Wash the filters in warm mild soapy water, rinse in clean fresh cold water and let completely dry.

DO NOT scrub the filters or place in a dishwasher.

DO NOT use a hair drier to dry the filters.

Refit the Filters (or replace the white one with a new one) in the reverse method used for disassembly.

IMPORTANT: When refitting the filter assembly back into the dust canister, it must be fitted in the correct orientation.

To ensure this happens, there are three tabs on the edge of the filter which align with three slots in the dust canister.

Rotate the filter assembly until the tabs align with the correct slots and then drop in.



9.2 Cleaning Dust Canister

Remove the dust canister as described previously and remove the Filter assembly as described previously.



Wash the dust canister in warm mild soapy water, rinse in clean fresh cold water and let completely dry.

DO NOT scrub the dust canister or place in a dishwasher.

DO NOT use a hair drier to dry the dust canister.

Reassemble and Refit the in the reverse method used for disassembly.

9.3 Cleaning the Vacuum Cleaner Body and Tools

Do not clean the vacuum cleaner, components or accessories using petrol or any other flammable liquid or solvents, etc.

Clean only the outside of the vacuum cleaner.

Use only a moist cloth and mild detergent for cleaning the vacuum cleaner, components and accessories.

After cleaning, wipe off the moisture on vacuum cleaner, components and accessories with a dry cloth.

Do Not place accessories / components in a dishwasher.

9.4 Cleaning the Motorised Floor Head

The Rotary Brush in the floor head can be removed for easy cleaning and removable of hair etc.

Ensure the Floor Head is removed from the extension tube or vacuum cleaner.

Turn over so that the bottom face is facing up.



There is a small locking clip on the right side which needs to be rotated $\frac{1}{4}$ turn anticlockwise to unlock. You can use a flat blade screw driver or a small coin.

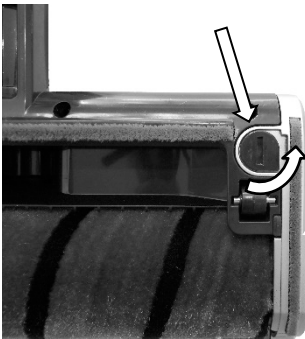

Grasp the floor head and rotate the end cap anticlockwise to unlatch and then pull straight out and off.



Grasp the rotary brush and slide out sideways

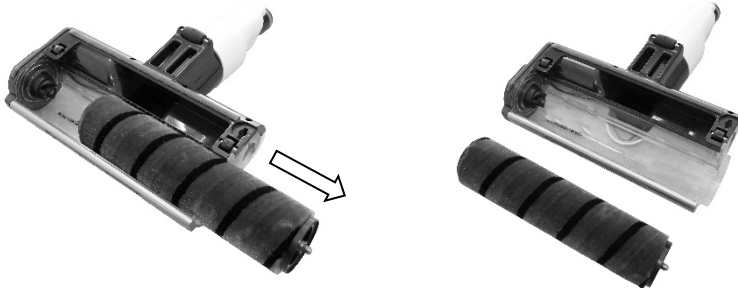

Remove any hair, thread and debris etc. that may have caught around the end bearings, wheels or stuck in the openings.

After cleaning, refit the brush and end cap in reverse order to disassembling then ensure the small locking clip on the right side which is locked again by rotating $\frac{1}{4}$ turn clockwise to lock. You can use a flat blade screw driver or a small coin.

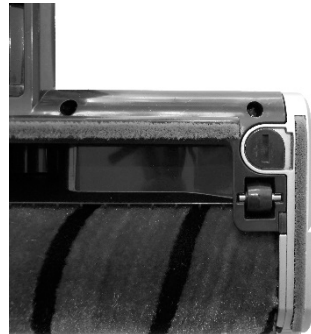
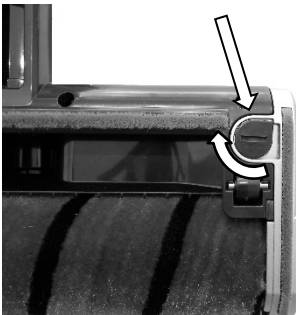

10 Storage

When finished using the vacuum cleaner, empty the dust canister and clean the filters, then place on the Charging / Storage Stand. You can either recharge the battery first, or store it away in a dry cool place.

Switch off and unplug the battery charger when not in use.

11 Troubleshooting

Will Not Switch On	Check that the Battery is fully charged.
Only 1, 2 or 3 Indicator Lights are lit on the battery.	This is correct. All 4 lights will be on when the battery is fully charged. 3 lights when three quarter charged, 2 lights when half charge, 1 light on when battery is running low.
Noisy operation	Clean the Filter and empty the Dust Canister
	Check for partial blockages and unblock.
Suction Not Strong	Clean the Filter and empty the Dust Canister. Check for blockages and unblock Check that the Battery is fully charged. Please call 1300 105 888 to order a new Filter or Battery.
	Speed setting may only be set to Low. Press the Speed Button to select High power mode.
Floor Head hard to push	The Rotary Brush in the floor head may be jammed with debris etc.
	Ensure the Vacuum Cleaner is switched off then remove the debris from the brush. Or, the carpet may be too long.
Static Shock	In some rare instances, one or two users may feel an electric discharge when touching or using the vacuum cleaner during or after use. This is a well know phenomena of Static Electricity discharge that happens mostly when the user vacuums a synthetic fibre carpet or other synthetic surfaces. It can also be more prevalent in dry and cool environments. Although the feeling of the Static Electricity can be unpleasant for the user, it is not dangerous and is not a fault of the vacuum cleaner. If this static discharge is a problem for the user, the user could try wearing insulating footwear during vacuuming (i.e. rubber or leather soles) or increase the humidity / heat level in the surrounding environment or both.

13 Warranty Against Defect

12 Month Warranty

Thank you for your purchase from Kmart.

Kmart Australia Ltd warrants your new product to be free from defects in materials and workmanship for the period stated above, from the date of purchase, provided that the product is used in accordance with accompanying recommendations or instructions where provided. This warranty is in addition to your rights under the Australian Consumer Law.

Kmart will provide you with your choice of a refund, repair or exchange (where possible) for this product if it becomes defective within the warranty period. Kmart will bear the reasonable expense of claiming the warranty. This warranty will no longer apply where the defect is a result of alteration, accident, misuse, abuse or neglect.

Please retain your receipt as proof of purchase and contact our Customer Service Centre 1800 124 125 (Australia) or 0800 945 995 (New Zealand) or alternatively, via Customer Help at Kmart.com.au for any difficulties with your product. Warranty claims and claims for expense incurred in returning this product can be addressed to our Customer Service Centre at 690 Springvale Rd, Mulgrave Vic 3170.

Our goods come with guarantees that cannot be excluded under the Australian Consumer Law. You are entitled to a replacement or refund for a major failure and compensation for any other reasonably foreseeable loss or damage. You are also entitled to have the goods repaired or replaced if the goods fail to be of acceptable quality and the failure does not amount to a major failure.

For New Zealand customers, this warranty is in addition to statutory rights observed under New Zealand legislation.

IMPORTANT!

For all technical queries or difficulties in operating the product and for spare parts, contact H.E. Group customer service 1300 105 888 (Australia) and 09 8870 447 (New Zealand).

