



Specification:

Round 32mm 4 pack LED spot light kit
4 x 0.5W LED module RGB
Dia 32 x 55 x 280mm
IP rating: IP65 (Luminaire), IP44 (LED driver)
AU Plug-in LED driver:
Input: 100-240V ~ 50/60 Hz
Output: 12V DC, 500 mA 6W max.
iOS 9.0 or higher, Android 4.4 or higher
WiFi IEEE 802.11N, 2.4GHz

 **IP65**
For luminaire

 **IP44** 
For LED driver

Warning:

This system operates at Safety Extra Low Voltage (12V), via a LED driver. Never connect the light fittings directly to the mains without using a driver. Up to 12 spot lights can be connected with the supplied LED driver.
Avoid locating any cables in positions that would cause a trip hazard. Position cables away from areas where they may be at risk from being cut, trapped or damaged.
Do not stare directly at the LED light beam.
The light source of this light fitting is not replaceable; when the light source reaches its end of life the whole luminaire shall be replaced.
If part of the product is damaged, it cannot be repaired and must be destroyed. Waste electrical products should not be disposed of with household waste. Please recycle where facilities exist. Check with your local authority for recycling advice.
This system works via WI-FI control, please sure that BEFORE you install your kit there is good 2.4Ghz Wi-Fi signal coverage in the location you going to place the smart WIFI controller.
Only support 2.4Ghz WI-FI networks with WEP and WPA/WPA2 encryptions. Portal and WPA/WPA2 enterprise are not supported, 5Ghz Wi-Fi is not supported un-secured open networks and hidden SSIDs are not supported.

Installation:

Switch off the power source.
Deciding the layout of the light fittings, ensure that the cable length is enough to suit the intended location of the light fitting and power source.
Spike light: Push the stem into the LED light head and then push the stem into the spike. Push the assembled products into the ground.
Surface mounting: Fix the mounting bracket to the wall using the supplied screw and wall plug, push the LED light head into the mounting bracket and secure in position.
Connect each LED light to the next LED light ensuring the arrows on connectors are facing each other and all plugs are fully fitted into the sockets.
Use the supplied end cap to cover last socket which is not being used, to prevent water ingress.
Connect the extension cable and smart controller to the LED driver.
Plug the LED driver into the mains socket and switch on.

Care and maintenance:

We recommend cleaning with a soft dry cloth. Do not use solvents or abrasive cleaners as these could damage the finish.
For your safety, always switch off the supply before cleaning.

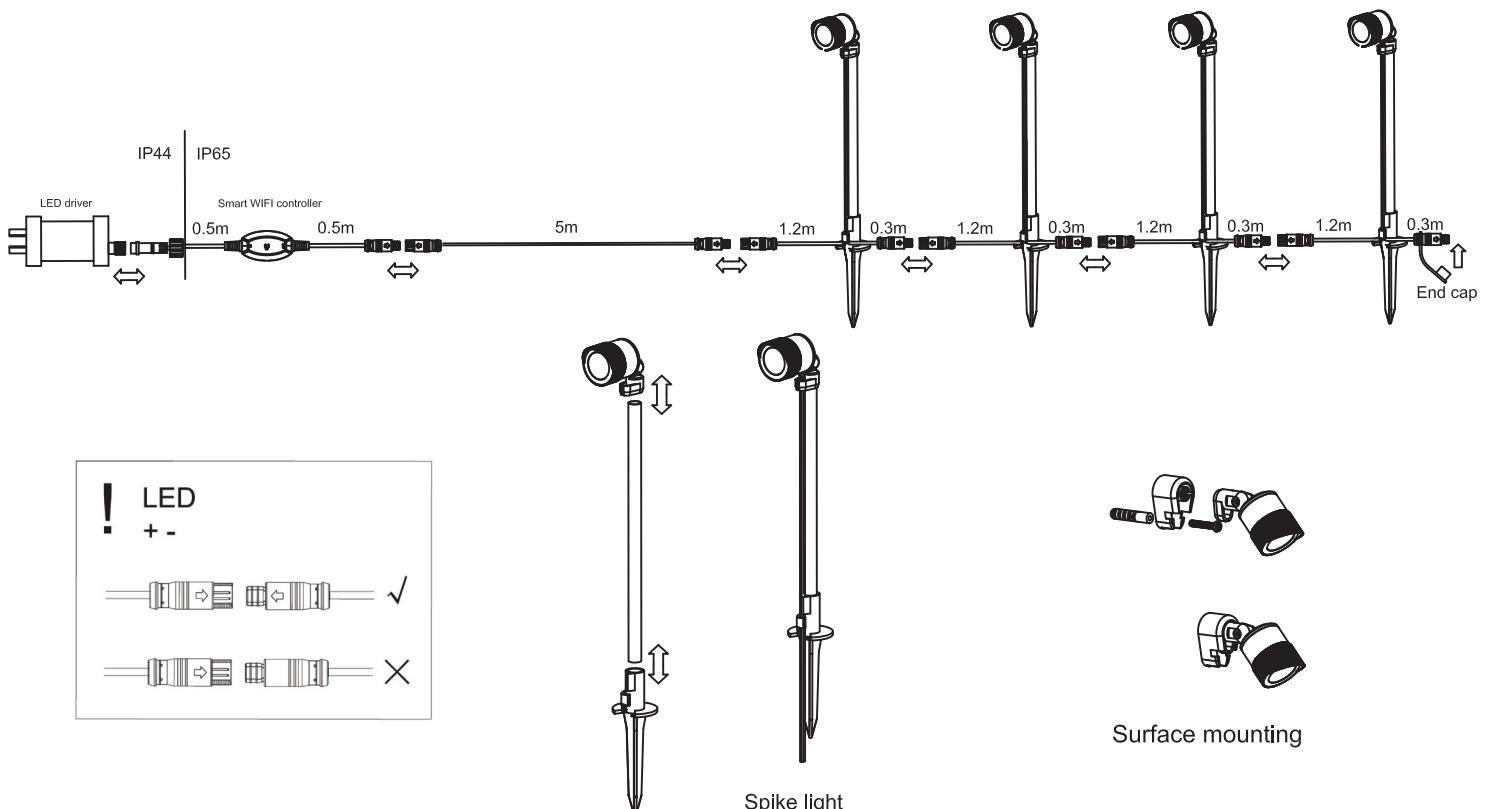

Mirabella Genio smart connection user guide

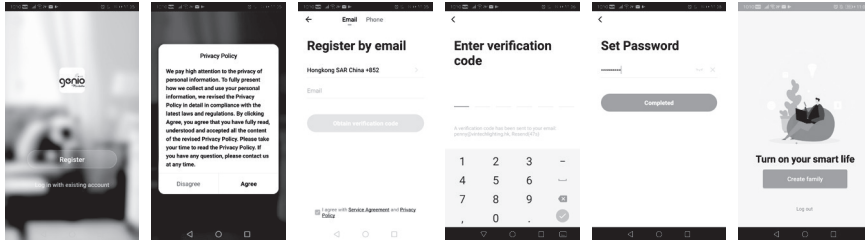

STEP 1

You will need an active internet connection. Scan the QR code to download the App or log in to Google Play or the App Store on your mobile phone or tablet and search "Mirabella Genio" Click 'Download'. Once downloaded, click on the app to open and proceed to log in or register.

STEP 2

Read the Privacy Policy carefully. Click 'Agree' if you wish to continue with the set up. You can choose to register by email or phone; complete all required fields. Click 'Obtain verification code'. Enter the verification code that you receive. Set a Password.

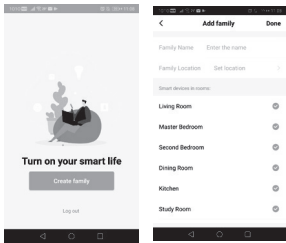

STEP 3

Click 'create family' to turn on your Smart life. Enter family name, or any name you wish. Set location. Tick or untick relevant rooms according to the property. If the room is not present, add a room, e.g. 'Patio'. You can change room settings at any time.

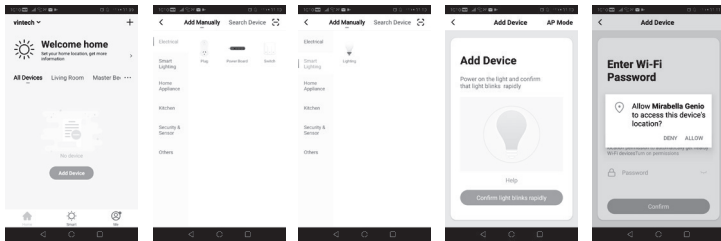

STEP 4

It is now time to add your smart lighting. Click 'Add Device'. Click 'Lighting' on the left hand side. Click 'Lighting' on the main screen. Turn the light on. When the light starts to blink repeatedly, click 'Confirm lights blink rapidly'. If the light is not blinking when it is first installed, you must set it to pair mode. To do this, turn the light on and leave for 10 seconds, Turn off and on repeatedly, 3 times.

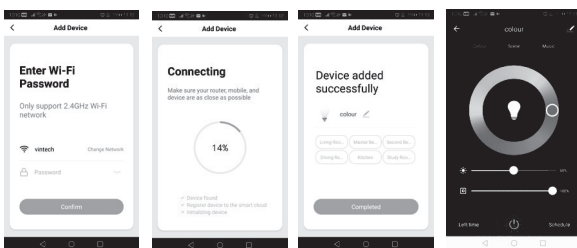

STEP 5

NOTE: Only supports 2.4GHz Wi-Fi networks. Enter your Wi-Fi details and click 'OK'. Once successfully connected, you can keep the default name or change it and assign the light to a room. Finally, click 'Completed'. Congratulations, you are now free to enjoy controlling your light through the smart app. If connection fails, please consider try disabling the 5ghz wifi in your router, then try pairing it again.

STEP 6

Click the icon in the top right hand corner of the app to display additional options, such as pairing with your Amazon Alexa or Google Assistant.

Click an icon in the Supported Third-Party Control section. Follow the connection instructions described here.

