

anko

Build Your Own Solar Space Robot

PHYSICS

- > integrates technology and handcrafts
- > adjustable solar panel
- > perfect to play under sunlight
- > easy to assemble, no glue required
- > moving robotic arms
- > battery free

8+ years

STEM
SCIENCE
TECHNOLOGY
ENGINEERING
MATHS



Convert sunlight into electricity! See the robot powered up by the sun!

Components

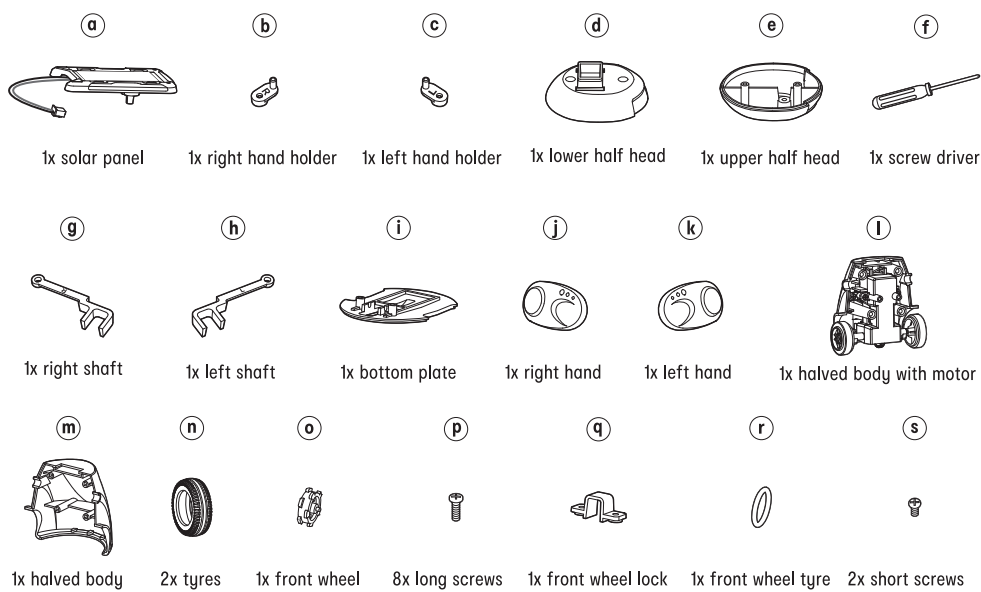

Warning: You may use a 100W light bulb at about 5cm away from the solar panel for testing purposes. This way you can see how it will operate under ordinary sunlight. However this is for testing purposes for a short period of time only and not for normal use. Placing the light bulb close to the solar panel for long periods may melt the plastics or damage the solar panel under the large amount of heat. **Warning:** Overheating hazards. Do not touch the solar panel.

Educational Hints

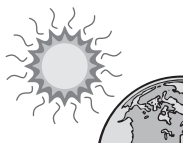

Solar energy

The sunlight we see everyday carries energy. If you stand under the sun for a while, you can feel the heat which is carried by sunlight. The sun shines and provides warmth and heat to us. It is also an energy provider to form wind, to support plant growth and to provide warm and hot temperatures. The energy from sunlight is called "solar energy" as a general term.

Why solar energy is said to be environmentally friendly?

As a power source, sunlight does not create pollutants. Solar energy comes from the sun and is an ever continuous power source. It will not exhaust and is therefore a kind of "renewable" energy. In generating electricity, unlike a traditional power plant, solar power is more environmentally friendly because it will not produce pollution. To produce electricity with solar energy, a solar panel is required:

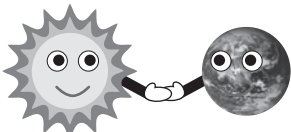

Solar panel

A solar panel is a device which can convert sunlight to electricity. The key components are layers of semi-conductors to form a solar cell. When light falls on a specific arrangement of semi-conducting material, some photons of sunlight will "kick" electrons to flow and form currents. Then electricity is created. This way light energy is converted to electrical energy. No pollutants are created in this process. As technology advances, different combinations of semi-conducting materials are created, which have different efficiency and costs. Therefore we can see more and more solar power products in our daily appliances. Some examples are:



Have you ever thought of the question that if using a solar power to generate electricity is that good, then why it has not been thrived everywhere?

The reason is that, solar cells are costly compared to the electricity that they can produce. The cost-effectiveness issue is a major concern for many places. Therefore people still stick to traditional power plants. Maybe someday when technology advances, we can see lots of devices using solar energy!

Structure of a solar panel

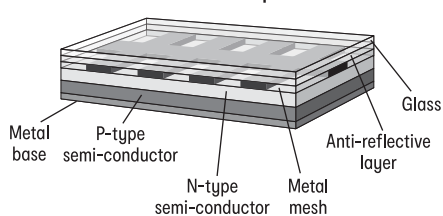

PRODUCT MAY VARY SLIGHTLY FROM IMAGES SHOWN. PLEASE KEEP INSTRUCTION MANUAL FOR FUTURE REFERENCE.

WARNING: CONTAINS LEAD WITH FUNCTIONAL SHARP POINT.

WARNING: CHOKING HAZARD

SMALL PARTS. NOT SUITABLE FOR CHILDREN UNDER 3 YEARS.

WARNING: FOR SAFETY REASONS, REMOVE ALL TAGS, LABELS AND PLASTIC FASTENERS BEFORE GIVING THIS TOY TO YOUR CHILD.

WARNING: HAIR ENTANGLEMENT MAY OCCUR IF THE CHILD'S HEAD IS TOO CLOSE TO THE MOTORIZED UNIT OF THIS TOY. ADULT SUPERVISION AND ASSISTANCE IS REQUIRED.

FOR BEST RESULTS USE OUTSIDE IN DIRECT SUNLIGHT.

THIS PRODUCT WILL NOT WORK IN CLOUDY LOCATIONS OR UNDER FLUORESCENT LIGHTS.

If at any time in the future you should need to dispose of this product please note that waste electrical products should not be disposed of with household waste. Please recycle where facilities exist. Check with your local authority or retailer for recycling advice. (Waste Electrical and Electronic Equipment Directive) 42-887-966

MADE IN CHINA

FOR AU/ NZ: IMPORTED FOR KMART STORES IN AUSTRALIA AND NEW ZEALAND. FOR USA: IMPORTED BY ANKO RETAIL INC. 19500 ALDERWOOD MALL PARKWAY LYNNWOOD WA 98036 USA.

How to Assemble

STEP 1:

Encircle the tires to the wheels of the main body.

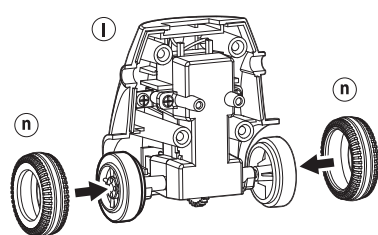

STEP 2:

Assemble the head. Turn it over and use 2 long screws to fasten.

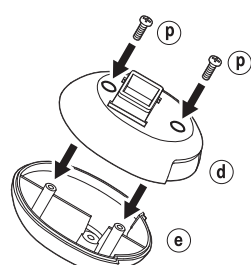

STEP 3:

Fix the head to the main body.

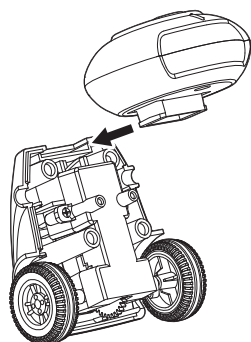

STEP 4:

Put the right joint connector onto the joint of the RIGHT arm. Use a short screw to fasten. Then put the action rod into it. Note that there is a letter R on the joint connector and action rod. Do not mix up with the left ones which have a letter L on them.

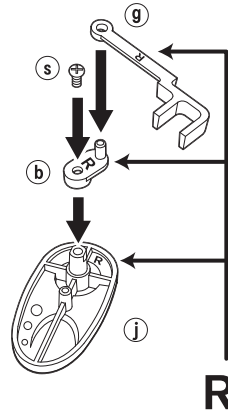

STEP 5:

Do the same thing to the LEFT arm part. Note that there is a letter L on the joint connector and action rod. Do not mix up with the right ones which have a letter R on them.

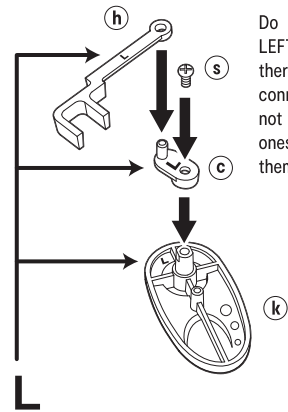

STEP 6: Put the left and the right arms onto the shoulder slot on the main body. Note that the action rod should be settled behind the wheels.

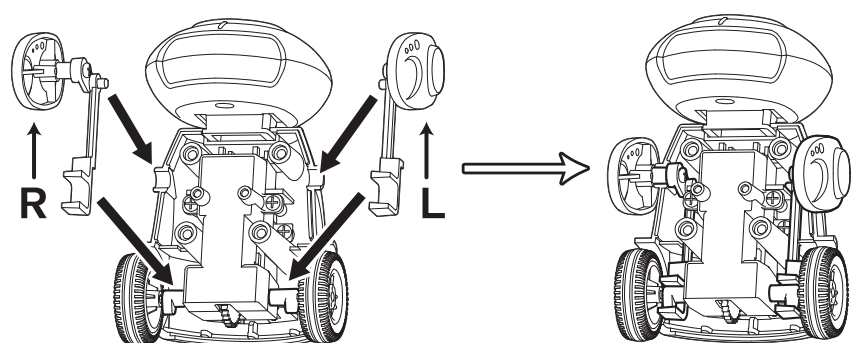

STEP 7:

Circle the tire to the front wheel.

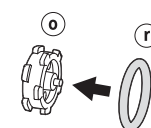

STEP 8: Put the front wheel onto the base. Cover it with the front wheel cover. Then use 2 long screws to tighten.

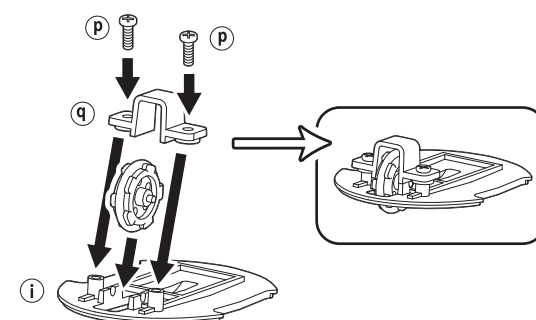

STEP 9:

Assemble the base with the main body.

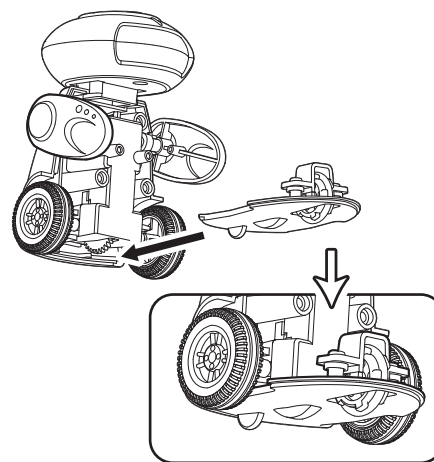

STEP 10:

Assemble the front cover with the main body. Use 4 long screws to lock.

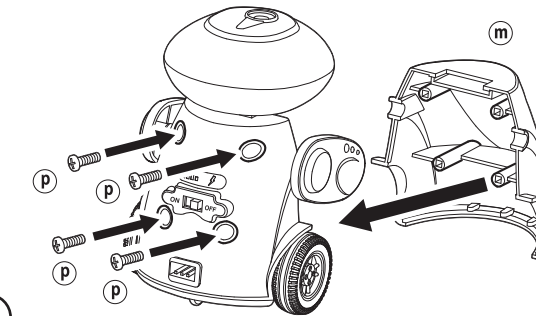

STEP 11:

Insert the solar panel onto the body and insert the plug to the socket to finish the assembly.

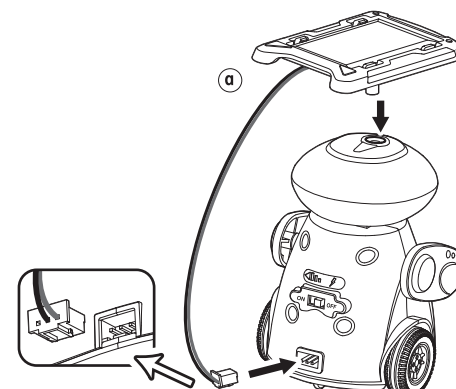

How To Play

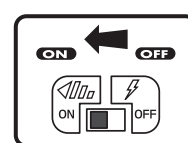

Now the set up of the eco-kit is finished. Switch to ON and put it under the sun to let it run! You can adjust the solar panel so that it faces the direction of the sun. The stronger the sunlight falling on the solar panel, the more powerful the eco-kit will go!

IMPORTANT NOTE: This eco-kit can not be charged but only direct play under the sunlight.