

Assembly Instructions

42900740 3 STACKING SHELVES

Please read instructions carefully. Remove all wrapping material, staples and packing staples from the carton. See parts list and hardware list for guidance. Be sure you have all parts before you start assembling. Place all wooden furniture parts on a clean and flat soft surface, such as carpet or a rug to prevent from being scratched. When cleaning the surface, use a soft damp cloth or dry clean cloth.

-This wall shelf needs to be mounted securely. Please use appropriate fixing types for your wall type.
If in doubt, please consult a builder/DIY specialist.

-Attention: We recommend a periodic check on all fixing points to make sure they remain fully tightened.

1. Hardware List

- D. 2 x screws (included)
- E. 2 x expansion bolts (included)

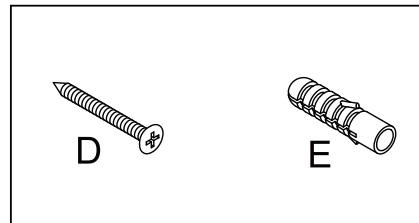

To Assemble:

- Check the contents to make sure that nothing is missing.
- Pull out the parts and fittings as shown. Assemble product step by step.
- It is preferable to rest the product on a soft surface to avoid damage during assembly.
- Do not overtighten screws and fittings.
- Retighten all screws and fittings periodically.

WARNING:

- This package contains small parts and sharp points.
- Keep away from children and babies until assembly is complete.
- Take care if using power tools to assemble the product.
- DO NOT STAND OR SIT ON THIS ITEM. DO NOT USE THIS ITEM UNLESS ALL BOLTS, SCREWS AND KNOBS ARE FIRMLY SECURED.
- DO NOT PLACE HOT ITEMS DIRECTLY ON THIS ITEM.
- KEEP IT PROTECTED FROM DIRECT SUNLIGHT. FOR INDOOR USE ONLY.
- MAXIMUM SAFE LOAD WEIGHT: 3kg/6.6lb PER LAYER, DO NOT EXCEED MORE THAN 5kg/11lb FOR WHOLE PRODUCT.

2. Parts List

- A. 1 x large shelf
- B. 1 x small shelf
- C. 1 x medium shelf

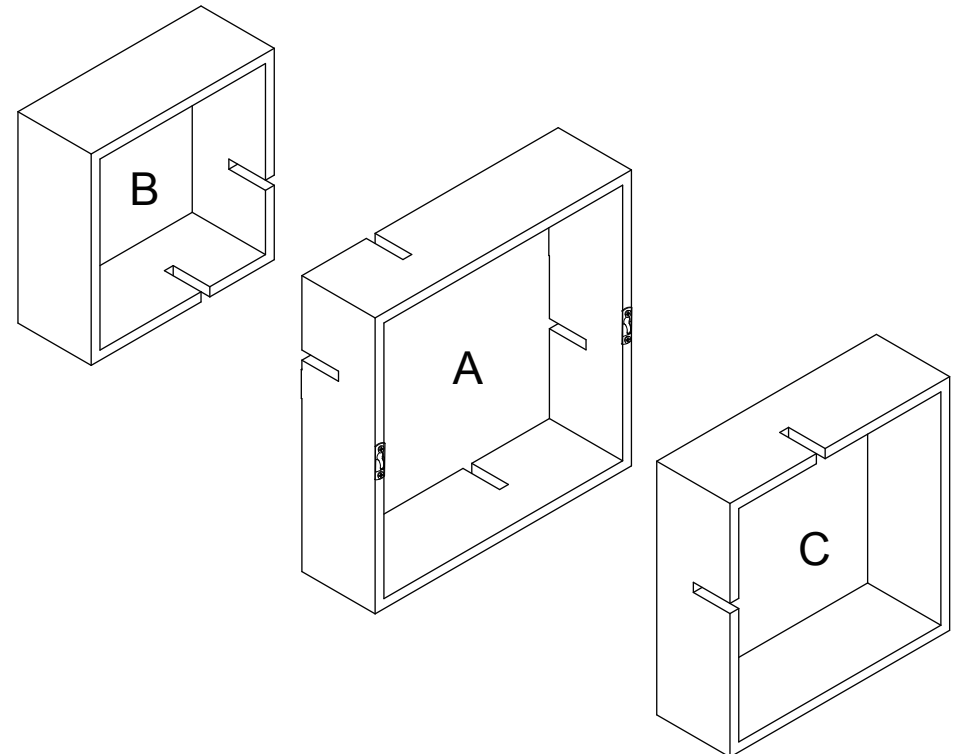

Step 1

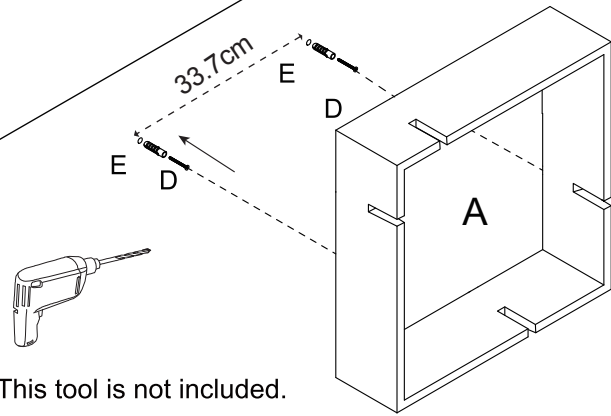

This tool is not included.

Before drilling, double check the measurements of the drill holes and the position of the hooks to ensure secure attachment of shelf to the wall.

Step 2

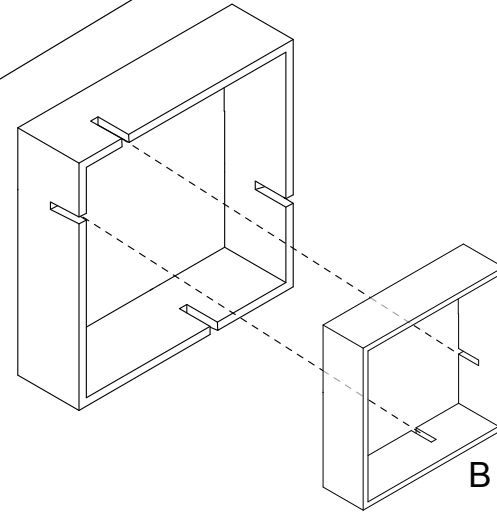

Step 3

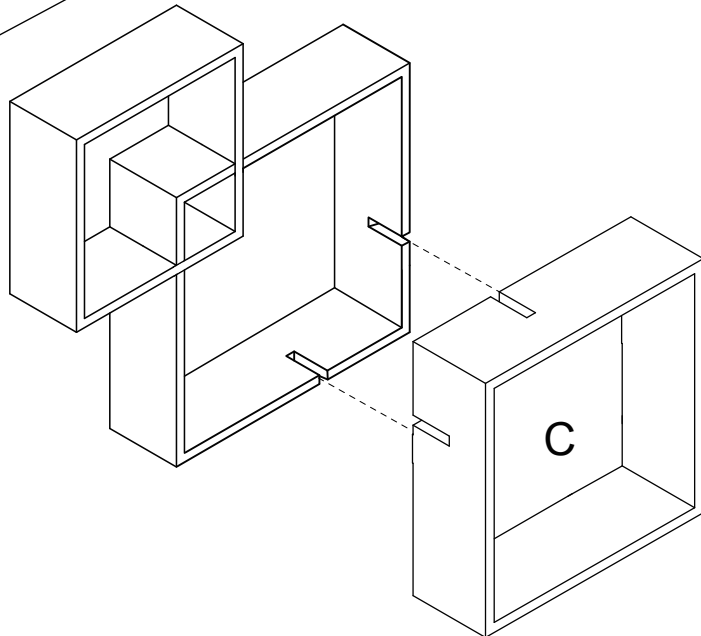

Step 4

