

STEP 1: SET UP BASE AND STAND

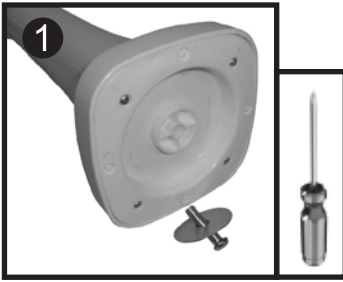

Unscrew the **Screw** and **Washer** from the bottom of the stand post. (Note: Philips Head screwdriver is required.)

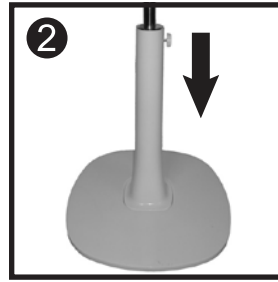

Place the **Base** on the floor and fit the post into the recess in the top of the base.

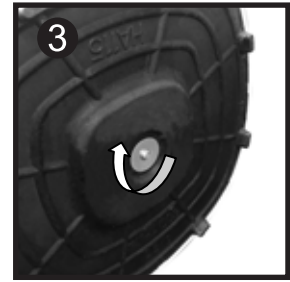

Tip up the base. Place the **Screw** and **Washer** through the hole and tighten the **Screw** and **Washer** (Clockwise).

STEP 2: ATTACH HEAD TO STAND



Loosen the post **Height Adjustment Locking Knob**, pull out the inner chrome tube then retighten the locking screw.

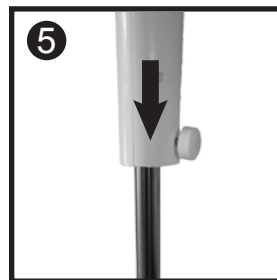

Place **Motor Assembly** at the top of the stand post and lower down all the way.

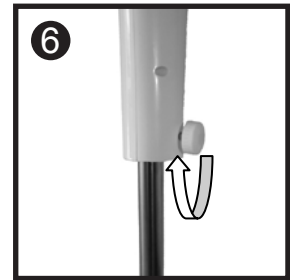

Tighten the **Head to Post Locking Screw** (Clockwise). Do Not overtighten.

STEP 3: INSTALL SAFETY GRILLE AND FAN BLADE

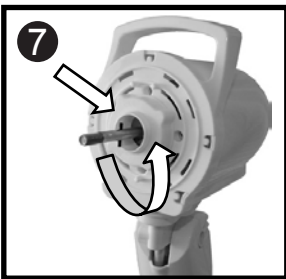

Unscrew the **Locking Nut** (anticlockwise) on **Motor Assembly**.

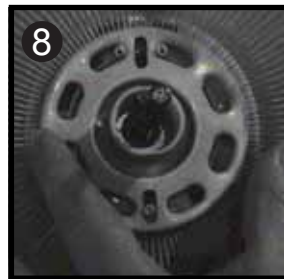

Place the **Back Safety Grille** into position ensuring the safety grille fits onto the locating lugs.

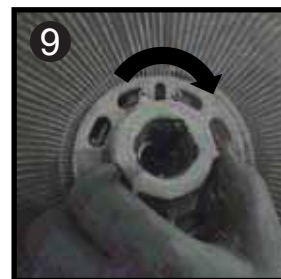

Fix the back safety grille into position by screwing the **Locking Nut** (clockwise) tightly by hand. Do not over tighten.

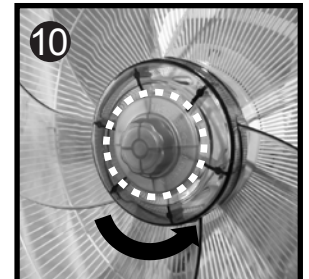

Place the **Fan Blade** onto the motor spindle. Secure the blade into place by gently tightening the **Spinner Nut** (anticlockwise) onto the end of the motor spindle.

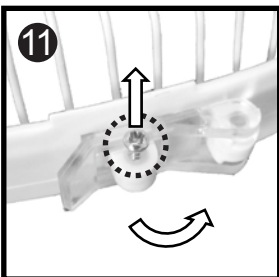

Take the **Front Safety Grille**, unscrew and remove the **Small Screw** in the locking mechanism at the bottom of the grille. Swing open the lever.

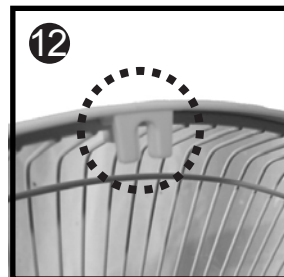

Place the **Location Hook** over the top centre of the rear grille and push down.

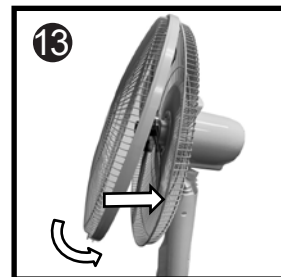

Swing down the front grille and press the plastic band onto the rear grille rim and squeeze the grille rims together ensuring the plastic band, front grill and rear grille are fully clipped together.

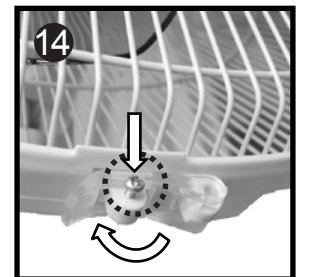

Secure the grilles by closing the lever to lock in place. Then refit the **Small Screw** and tighten.

If you are missing a part or having troubles when assembling the fan, please feel free to call our friendly customer service team on 1300 105 888 or via email info@hegroup.com.au. We will be glad to assist you.

STEP 4: SMARTPHONE CONTROL APP SETUP AND WI-FI PAIRING

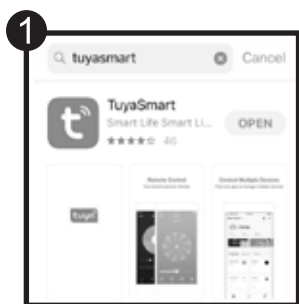

Search “**TuyaSmart**” in App Store or scan the TuyaSmart QR code. Download the app and install on your phone.

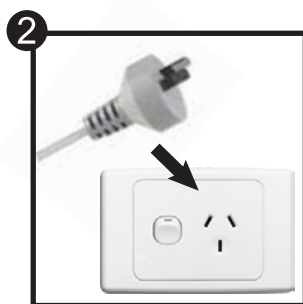

Plug the fan into a power point and switch on.

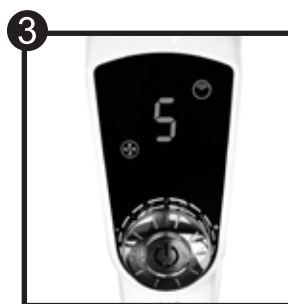

The Number Display and Icons will illuminate for a second and then turn off.



The Wi-Fi indicator light will illuminate and blink rapidly (approx. 2 times per second).

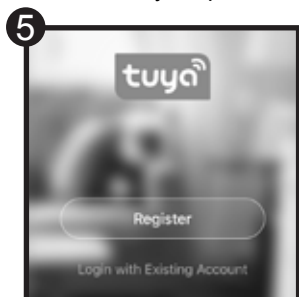

Start up the Tuya app and register with TuyaSmart.

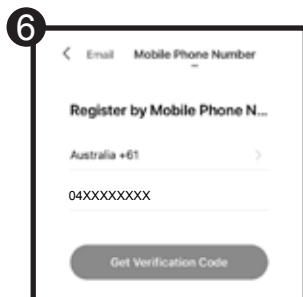

Choose either Email or Mobile Phone Number and fill in the details.

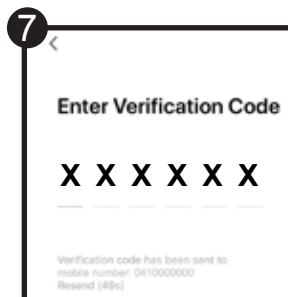

Enter Verification code (6 digits) sent to your Email or Mobile Phone Number.

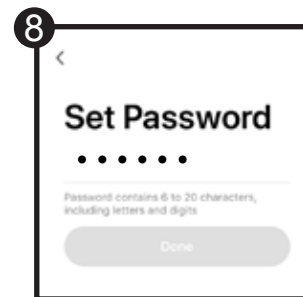

Set password for your TuyaSmart account.

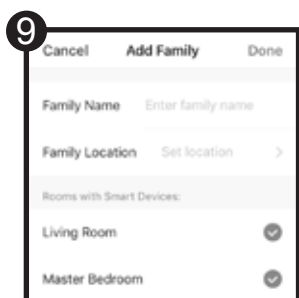

Press the “Create Family” button and enter your Family Name (or Nickname) and Family Location. *



Choose the room that the device will be added. Then press “Add Device”.



Select Small Home Appliance in the left column then press the Fan icon.



Press the button “Confirm indicator rapidly blink”.

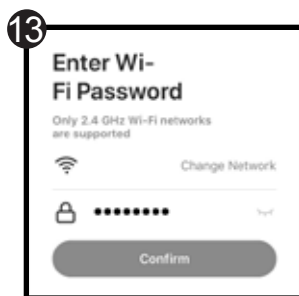

Choose the Wi-Fi net work and put in password to log in. **(Note: Only 2.4 GHz Wi-Fi networks are supported.)**

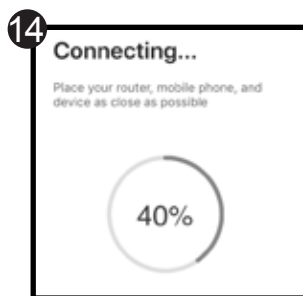

You will now see a progress % circle while connecting.

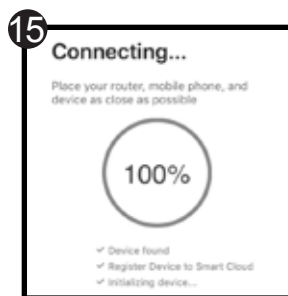

Once connected, it will state “Device added successfully”. **

* You can share the fan operation with your family. Just add your family members phone number inside the TuyaSmart phone App (Me > Family management > Family Settings > Add Member) then they can control the fan at the same time.

** Should you for any reason find that you are unable to pair the fan with your smartphone, or that the Wi-Fi indicator light does not blink rapidly, or you are changing the smartphone, you may need to reset the Wi-Fi to get it to pair properly. Please refer to section “How to Reset the Fan Wi-Fi” in the instruction manual.



TuyaSmart app QR code

If you are missing a part or having troubles when assembling the fan, please feel free to call our friendly customer service team on 1300 105 888 or via email info@hegroup.com.au. We will be glad to assist you.

anko

Smart Fan with Wi-Fi User Manual

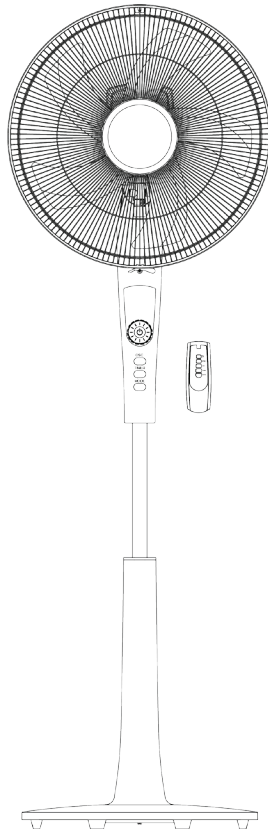

Model No.: HEGSM40
Rev 3

Note: The specifications and/or components of this appliance are subject to change without prior notice.

1	Safety Instructions	4
2	Components	6
3	Assembly	7
3.1	Base and Stand	7
3.2	Attach Head to Stand	8
3.3	Safety Grille and Fan Blade	9
4	Instructions for Use	13
4.1	Head Tilt	13
4.2	Height Adjustment	13
5	Remote Control	14
6	Smartphone Control App Setup	15
7	Wi-Fi Pairing	16
7.1	How to Reset the Fan Wi-Fi	17
8	Operation	18
8.1	Using the Fan Remote Control and Fan Control Panel	18
8.2	Fan Modes	19
8.2.1	Normal Mode	19
8.2.2	Nature Mode	19
8.2.3	Sleep Mode	19
8.3	Timer	20
8.4	Oscillating (Swing) Function	20
8.5	Using the Smart Phone App	20
9	Using Google Home Device	22
9.1	Link TuyaSmart account in Google Home Control	23
9.2	Control your Fan through Google Home	23
10	Using Amazon Echo Device	24
10.1	Control your Fan through Echo	24
11	Shared Device	25
12	Care and Cleaning	25
13	Storage	25
14	Troubleshooting	26
15	Warranty Against Defect	27

1 Safety Instructions

When using electrical appliances, basic safety precautions should always be followed, including the following:

- Carefully read this instruction manual before using appliance. 
- Ensure that the fan is switched off from the supply mains before removing the guard.
- Keep appliance out of reach of young children.
- This appliance is not intended for use by persons (including children) with reduced physical, sensory or mental capabilities, or lack of experience and knowledge, unless they have been given supervision or instruction concerning use of the appliance by a person responsible for their safety.
- Children should be supervised to ensure that they do not play with the appliance.
- Ensure children and babies do not play with plastic bags or any packaging materials.
- Do Not disassemble the appliance. There are no user serviceable parts inside.
- **VERY IMPORTANT:**
Ensure that appliance does not get wet (water splashes etc.).
Do not use appliance with wet hands.
Do not immerse appliance in water or other liquids or use near sinks, baths or showers.
- Always operate the appliance from a power source of the same voltage, frequency and rating as indicated on the product identification plate.
- Position the power supply lead properly so that they will not be walked on or pinched by items placed on or against them.
- Use appliance only for its intended use. Appliance is intended for household use only and not for commercial or industrial use.
- Do not use appliance if it has been dropped or any part of appliance (including cord or plug) has been damaged.
- If the supply cord is damaged, it must be replaced by the manufacturer, its service agent or similarly qualified persons in order to avoid a hazard.
- The use of accessories not intended for use with this appliance may cause injuries to the user or damage to the appliance.
- Do not install the unit on other appliances, on uneven surfaces or where it could be subject to: heat sources (e.g. radiators or stoves), direct sunlight, excessive dust or mechanical vibrations.

- Appliance should not be used outdoors, placed near a hot gas or electrical burner or placed in a heated oven.
- Do not install near any heat sources such as radiators, heat registers, stoves, or other apparatus that produce heat.
- Do not hang or wall-mount the appliance.
- Do not operate appliance underneath or near flammable or combustible materials (e.g. curtains). Keep at least 300mm clearance around sides, back, front and top.
- Do not allow curtains, drapes or any other items to drape across the appliance or openings.
- Unplug this apparatus during lightning storms or when unused for long periods of time.
- Do not block any ventilation openings.
- Never insert fingers or any other objects through the fan guard and ventilation openings.
- Do not use the product in oily or dirty areas (e.g. the kitchen, smoky place, etc), as the air vents may become blocked.
- Turn off and unplug before cleaning or storing.
- There are no user serviceable parts in this appliance.
- If this appliance is used by a third party, please supply the instruction manual with it.
- Do not misuse the cord. Never carry the appliance by the cord or pull to disconnect it from the outlet. Instead, grasp the plug and pull to disconnect.
- Do not insert or allow foreign objects to enter the grille openings as this may cause damage to the appliance and/or injury to the user.
- No liability can be accepted for any damage caused by non-compliance with these instructions or any other improper use or mishandling of appliance.

Additional Safety Instructions

If using an extension cord:

- The technical specifications of the extension cord must match or exceed the technical specifications of this appliance.

- Do not allow the cord to hang over the edge of the work surface or to come into contact with stoves or other hot surfaces.
- If the cord or plugs are worn or damaged, do not use.
- Unplug from the power socket by grasping the plug body - Do Not pull on the cord.

Read and Save These Instructions

2 Components

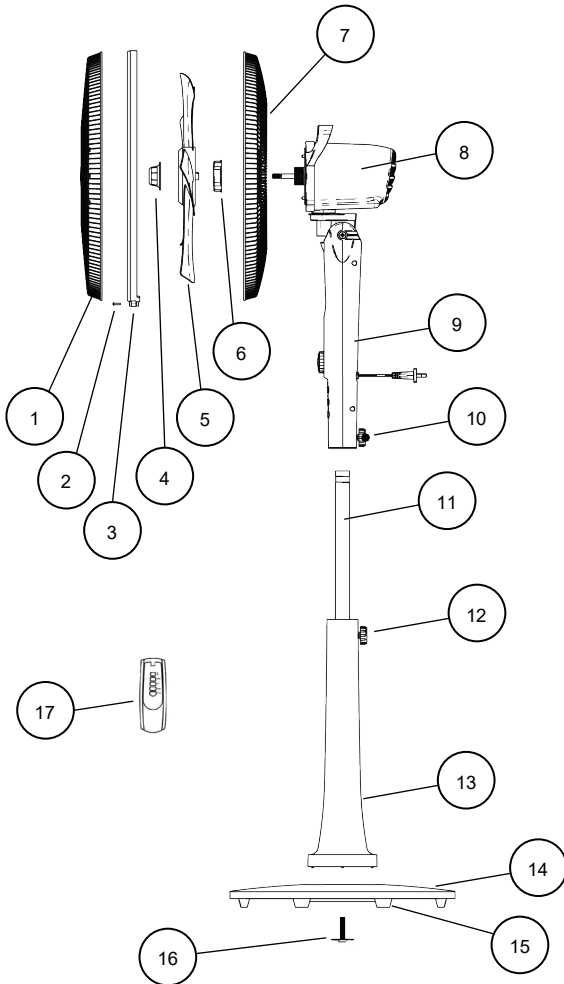

1	Front Grille
2	Locking Screw
3	Fan Grille Lock / Band
4	Fan Blade Spinner Nut
5	Fan Blade
6	Rear Grille Nut
7	Rear Grille
8	Motor Head Assembly
9	Control Body
10	Head to Post Locking Screw
11	Inner chrome tube
12	Height Adjustment Locking Screw
13	Stand Post
14	Base Cover
15	Base Weight
16	Screw and Washer
17	Remote Control

3 Assembly

3.1 Base and Stand

Your Fan has been boxed unassembled to minimise packaging waste. Each part is designed to fit together and be disassembled easily for cleaning or storage.

- First, with the aid of a Philips Head screwdriver, unscrew the Screw and Washer from the bottom of the stand post. (Anticlockwise).
- Place the base flat on the floor and fit the post into the recess in the top of the base.
- Whilst holding the post and base together, tip up so that the underneath of the base is accessible.
- Place the Screw and Washer through the hole and with the aid of a Philips Head screwdriver, tighten the Screw and Washer. (Clockwise).

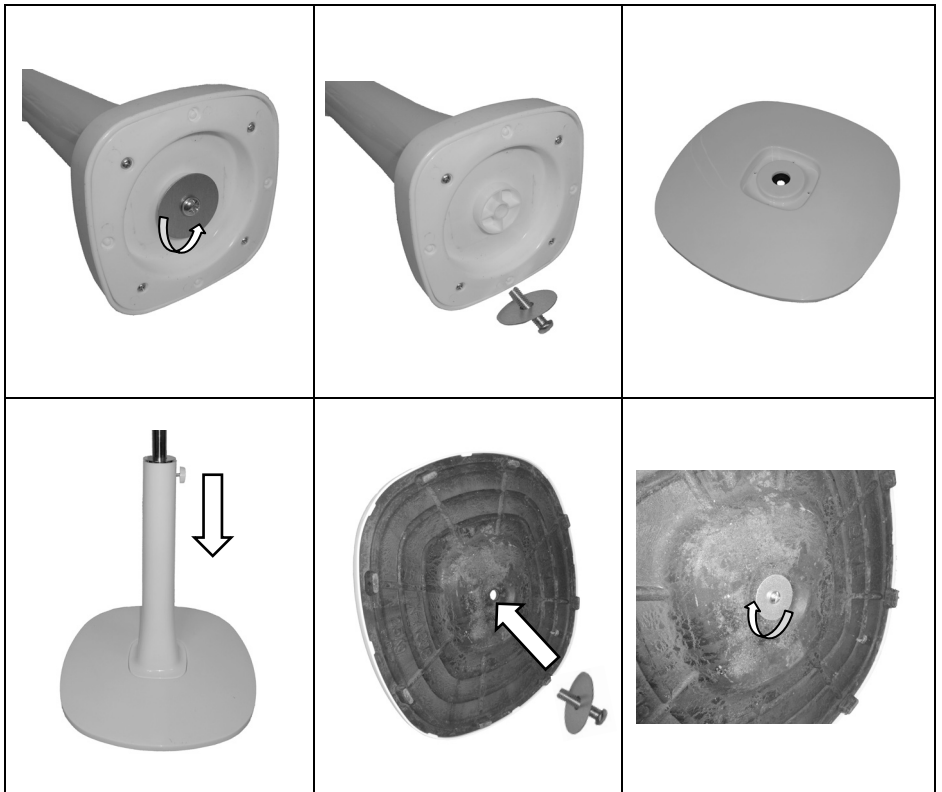

3.2 Attach Head to Stand

- Stand the Base with attached post on the floor.
- Loosen (anticlockwise) the post Height Adjustment Locking Screw, pull out the inner chrome tube to the desired height and then retighten the locking screw.
- Place Motor assembly at the top of the Stand Post and lower down all the way.

Note: if the motor assembly will not slide down the chrome post, loosed the Head to Post Locking Screw on the back of the motor assembly until it can slide down.

- Tighten the Head to Post Locking Screw (Clockwise). Do Not overtighten.



3.3 Safety Grille and Fan Blade

- To assemble the safety grille and blade assembly, first remove the Rear Grille Nut (Anticlockwise) from the front of the fan motor housing.

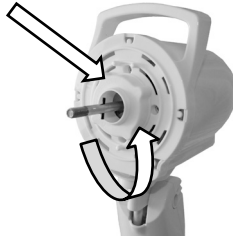

- Fit the rear safety grille into position with the slots in the 12 and 6 o'clock position ensuring the location pins are located as shown below, and refit the Nut and tighten.

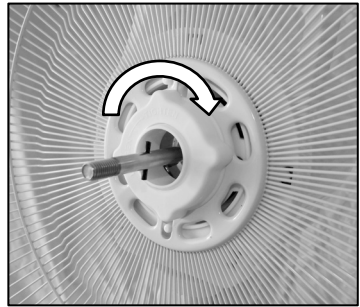
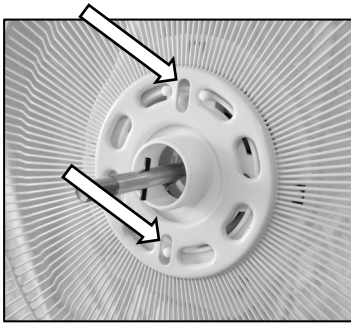

- If Fitted, remove the protective plastic sleeve from the motor spindle shaft and discard.
- Place the Fan Blade onto the motor spindle.

Note: The groove in the rear centre of the fan blade aligns with a T-bar on the motor spindle to ensure correct positioning.

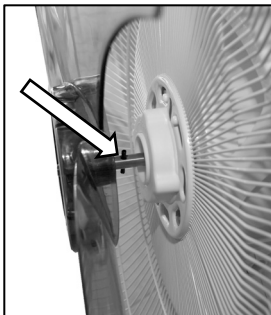

- Secure the blade into place by gently hand tightening the spinner nut **anticlockwise** onto the end of the motor spindle. The spinner nut is self-tightening when the motor starts, so do not over-tighten the spinner nut, just nip it up.

NOTE: The Spinner Nut screws on in the opposite way to a normal nut. It tightens when rotated Anticlockwise.

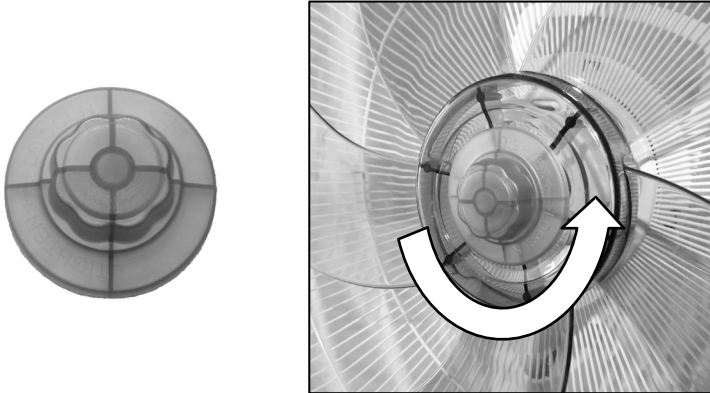

- Take the front grille and using a Philips Head screwdriver, unscrew and remove the small screw in the locking mechanism at the bottom of the grille.

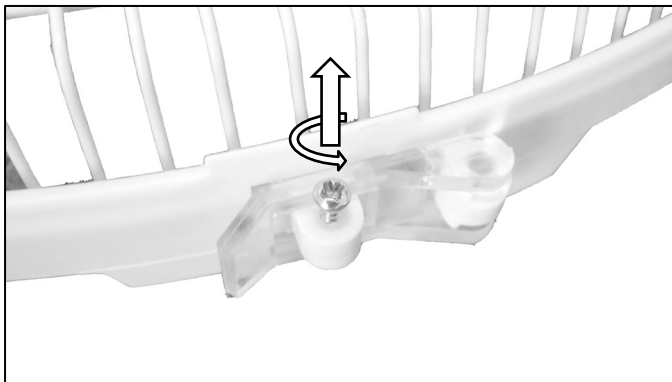

- Swing open the lever

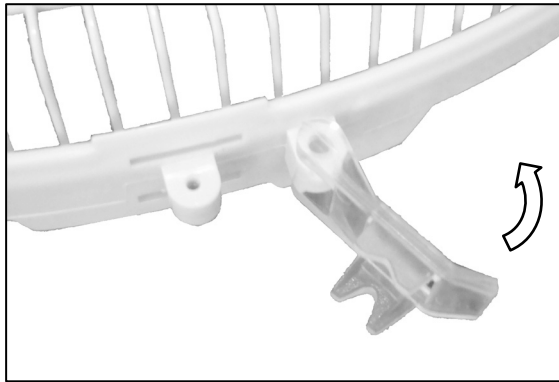

- Place the safety grille into position by lining up the location hook, at the top of the front grille, over the top and on to the centre spoke of the rear grille as shown and push down.

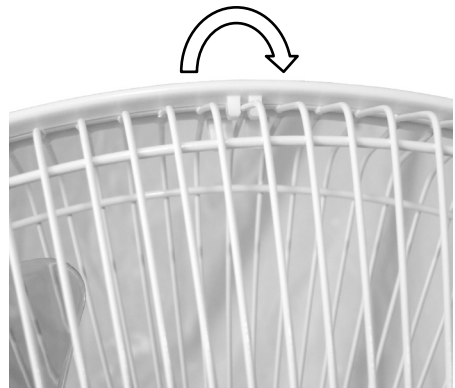
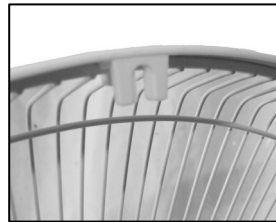
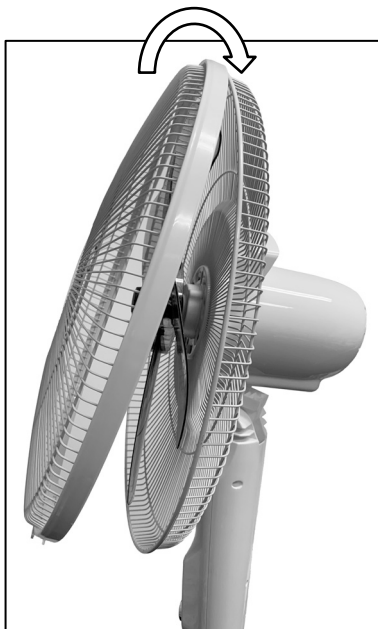

- Swing down the front grille and press the plastic band onto the rear grille rim and squeeze the grille rims together ensuring the plastic band, front grill and rear grille are fully clipped together.

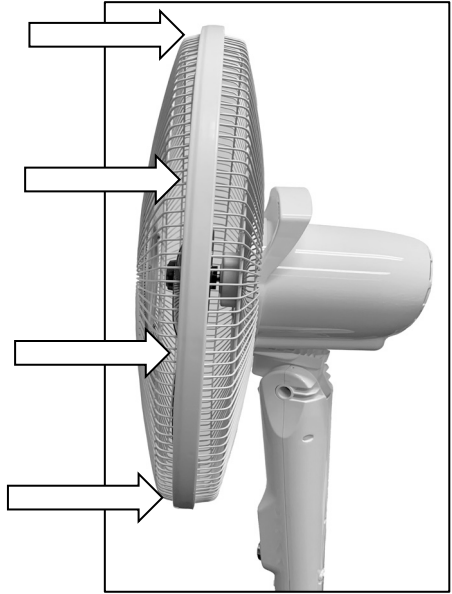
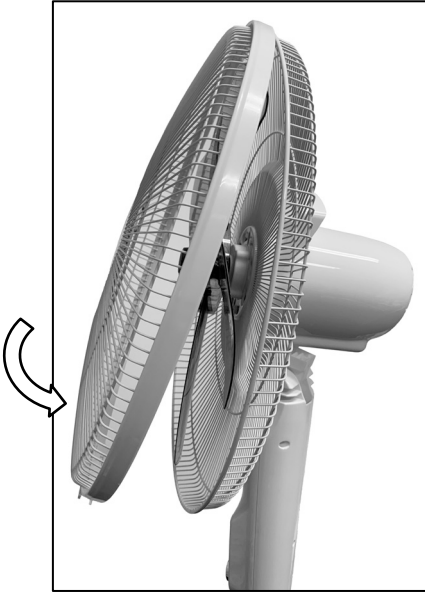

- Secure the grilles by closing the lever to lock in place. Then refit the small screw and use a Philips screwdriver to tighten.

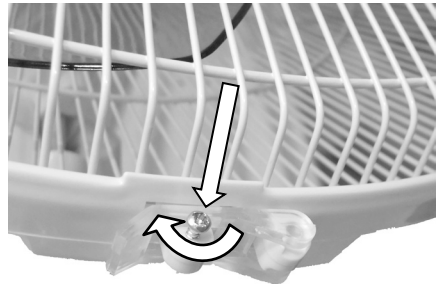
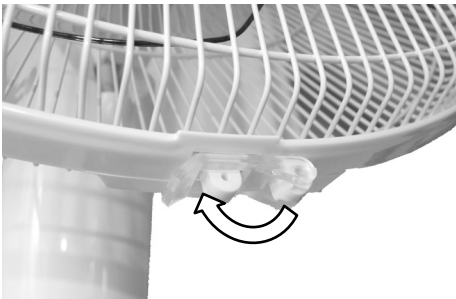

4 Instructions for Use

Remove the cable tie and unravel the cordset before operation.

DO NOT run the power cord under the stand

4.1 Head Tilt

The Fan Head can be adjusted Up and Down so as to blow air at the required angle.

Turn off and unplug prior to adjusting.

To adjust, grasp the Fan Grills and tilt the head either upward or downward to your desired angle.



4.2 Height Adjustment

The height of the fan can be adjusted.

Unscrew the Height Adjustment Locking Screw (Anticlockwise) on the back of the stand post, slide the inner post up or down and then tighten the Height Adjustment Locking Screw (Clockwise) again to lock in place.

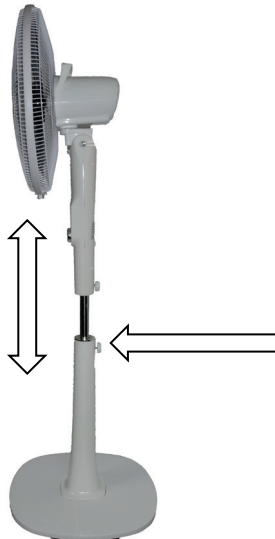

5 Remote Control

The fan comes with a remote control with the basic functions for your convenience. The remote control must be pointed towards the receiver, which is located inside the fan control panel, in order to work.



Do not block the line of sight between the remote control and the fans control panel.

Do not drop the remote control onto the floor or knock it against hard objects.

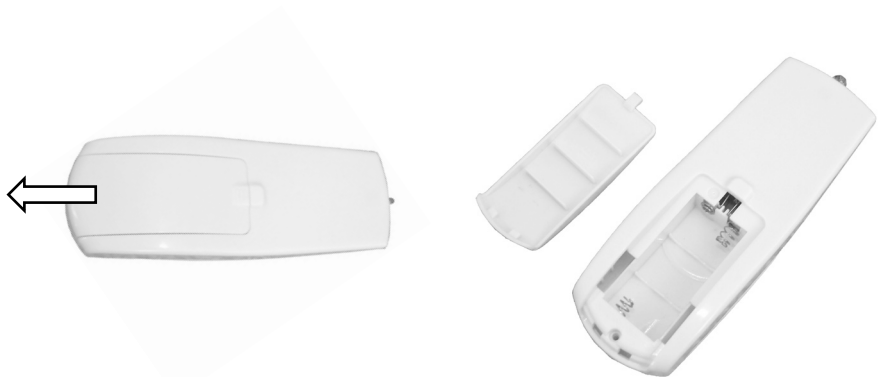

- To install the batteries, first slide the back battery cover off. (Batteries not included)
- Insert the batteries inside the battery compartment, matching polarity icons with those in the battery compartment and then refit the cover.
- Battery Type: "1.5V 2 x AAA". Alkaline Batteries work best (Batteries not included)
- Do not mix new and old batteries in the remote control.
- To prevent corrosion, remove the batteries if the remote control will not be used over a lengthy period.

6 Smartphone Control App Setup

For technical queries and difficulties in operating the product contact H.E. Group customer service 1300 105 888 (Australia) or 09 8870 447 (New Zealand).

Note: The Smart Home Pedestal Fan and TuyaSmart App only supports a 2.4GHz Wi-Fi network. It will not work on a 5GHz network.

To download the TuyaSmart App, either search your smartphone App store for **TuyaSmart**, search this link smartapp.tuya.com/tuyaSmart in your smartphone web browser or scan this QR code (below), and follow the instruction on how to download, install and register.

If the “Allow” message appears, press “Allow” TuyaSmart to access your location.



Note:

If you get a Network Error Message during the registration setup, this means it has timed out as the information was not entered quick enough.

You will need to close the App, restart it and input the information again.

You can register either by email address or mobile phone number.

If registering by mobile phone number, you need to select your country first, then enter your mobile phone number then press the “Obtain verification code”.

A text message will be sent to your mobile phone with the code number.

Note: if you choose to register with an email address, a code will be sent to your email address instead.

Input this code number and then this will take you to the “Set Password” page.

Enter a Password of your choice. Note: The Password must contain 6 – 20 characters, including alphabets and numbers, then press Complete.

If the “Allow” message appears, press “Allow” TuyaSmart to access your location.

Press the “Create Family” button.

Enter your Family name or nickname then select “Done”.

7 Wi-Fi Pairing

Note: The Smart Home Pedestal Fan and TuyaSmart App only supports a 2.4GHz Wi-Fi network. It will not work on a 5GHz network.

After downloading, installing the TuyaSmart App to your smart phone and registering, you need to pair your Smart Fan and Smart Phone to operate the fan through your phone.

1. Plug your fan into a power point and switch on.
2. The Number Display and Icons on the fan control panel will illuminate for a second and will then turn off.
3. If this is your first time pairing these devices, after approximately 5 seconds, the Wi-Fi indicator light will illuminate and will blink rapidly (approx. 2 times per second).
4. Open your TuyaSmart App and log in.
5. On the Welcome page, press the button “Add Device”
6. Select the “Home Appliance” menu in the left column. Note: there may be more than one “Home Appliance” menu so you will need to look through them all until you see “Fan”.
7. Press the “Fan” icon and this will then ask you to confirm that the Wi-Fi indicator light is rapidly blinking in the Fan Control Panel. Press the button to confirm.
8. If you haven't already logged into your Wi-Fi network, you can do that on the next page, then press “OK”.
9. You will now see a progress % circle while connecting.
10. Once connected, it will state “Device added successfully”.
11. You can change the name of your fan if you desire. To do this, press the small pencil icon next to the Fan image then change the name. The default name is “Smart Fan”. For example, you can rename it “Living Room Fan” then press save.

Refer to “Using the Smart Phone App” section in this instruction manual for more information.

12. On this same page, you can select the room in which the Fan will be used then press the “Completed” button.

You are now connected and ready to operate the fan through your smart phone.

To learn more about what the TuyaSmart App can do, or if you have any questions, please visit TuyaSmart website

<https://smartapp.tuya.com/tuyasmart/faq>

7.1 How to Reset the Fan Wi-Fi.

Should you for any reason find that you are unable to pair the fan with your smartphone, or that the Wi-Fi indicator light does not blink rapidly, or you are changing the smartphone, you may need to reset the Wi-Fi to get it to pair properly.

- Wi-Fi Indicator blinking rapidly: means ready to pair to Smartphone.
- Wi-Fi Indicator on permanently: means the fan has been paired and connected with the phone / network successfully.
- Wi-Fi Indicator not illuminated: means no Wi-Fi signal is available or the Wi-Fi is turned off. Make sure the smart fan and your phone is near your router and your router has a strong Wi-Fi signal.

To reset: Plug the fan into the power point and switch on.

Press the knob to turn the fan on then immediately Press and hold the knob for 2 seconds until you hear three squeals “ee.., ee.., ee..”

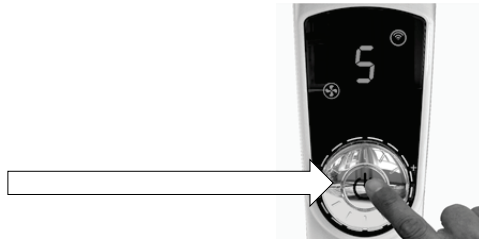

Wait until the Wi-Fi indicator light illuminates and starts to blink rapidly and then you can press and immediately release the knob again to turn the fan motor off.

You have now reset the Wi-Fi and the Wi-Fi indicator light will be blinking rapidly.

You can now follow the instructions on Wi-Fi Pairing in this instruction Manual.

Note: When you press the knob again, the fan will turn off, but the Wi-fi function is still working, you can switch on the fan with your smartphone App.

When you press the knob again for approximately 8 seconds until you hear the long squeal “ee---”, the fan will completely turn off, including the Wi-Fi signal. You will no longer be able to control the fan with your smartphone App until you turn the Wi-Fi back on.

8 Operation

The fan function can be operated 4 ways, using the supplied remote control, Fan control panel, smartphone App or smart device (such as Amazon Echo dot or Google home).

Note: Not all fan functions can be operated through the Smart Devices.

8.1 Using the Fan Remote Control and Fan Control Panel

- After ensuring the Fan has been assembled correctly and you have a strong Wi-Fi signal, plug into the power point and switch on.
- All the Indicator lights will illuminate (as shown below) for a second and will then turn off. Approximately 5 seconds later, the Red “Wi-Fi” symbol indicator light will illuminate and blink rapidly indicating it is in Wi-Fi pairing Mode. Refer to Wi-Fi setup for more information.

Note: If the Fan is already paired to your smartphone, this indicator symbol will remain light solid

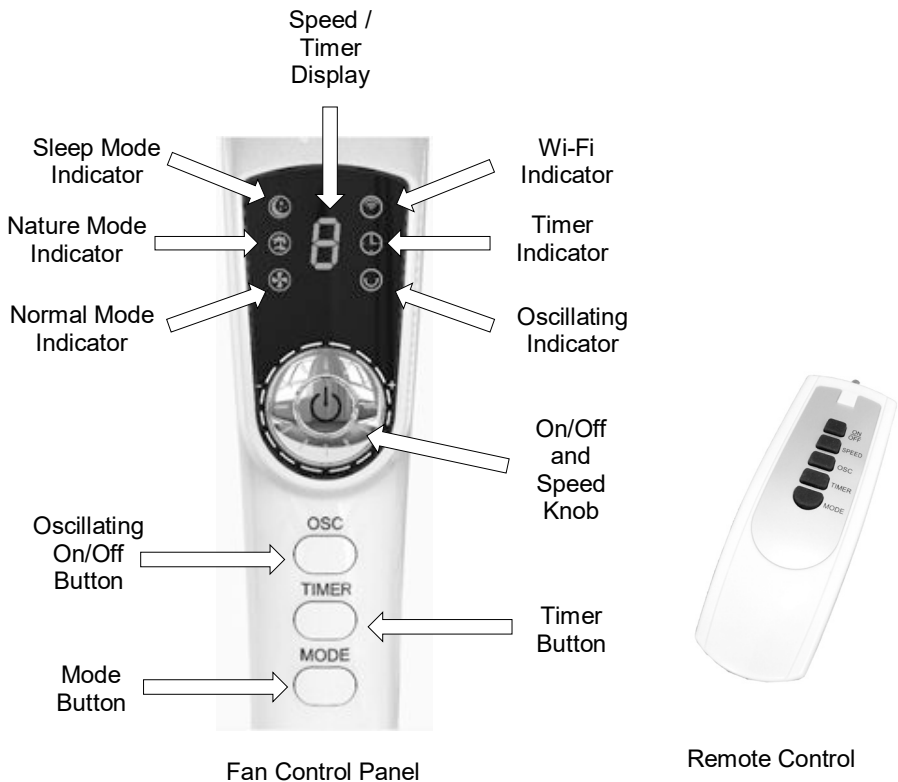

- Press the “ON/OFF” button on the remote control once, or the knob on the fan control panel. The “Fan” indicator light and Speed display number will illuminate. The fan will start to spin at Speed setting 5.
- Press the “SPEED” button on the remote control, or rotate the knob on the fan control panel one notch and the speed will increase to number 4.
- Repeat above steps to cycle the speed up to speed 8 and then onto speed 1 then 2 etc.
- To turn the fan off, press the “ON/OFF” button on the remote control or press the knob on the fan control panel.

8.2 Fan Modes

The Fan has three modes being: Normal, Nature, and Sleep.

With the Fan running in “Normal” mode (neither of the Sleep Mode or Nature Mode Indicator lights illuminated), press the “MODE” button on the remote control or Fan control Panel and the mode will change to “Nature” mode (The Nature Mode indicator light will illuminate).

Press the “MODE” button again and the mode will change to “Sleep” mode (Nature Mode Light will turn Off and the Sleep Mode indicator light will illuminate).

Press the “MODE” button again, and it will cycle back to “Normal” mode. (both of the Sleep Mode and Nature Mode Indicator lights will turn off)

8.2.1 Normal Mode

The “Normal” Mode is set by default when the unit is first turned on. The wind remains a constant flow.

8.2.2 Nature Mode

The “Nature” mode creates variable Wind Patterns so as to simulate the variable winds that you would experience outdoors.

In this mode the speed of the fan continually cycles through a mixed selection of low, medium, high and off in set intervals.

Depending on which Fan Speed is selected, the wind pattern will be different.

8.2.3 Sleep Mode

In “Sleep” mode, when the fan is set to either Medium or High Speeds, the fan speed will drop a speed level after approximately 30 minutes.

After approximately a further 30 minutes, the fan will automatically drop down to a lower fan speed.

The fan will continue to run in a Low Speed until manually turned off.

Note: To have the fan automatically turn off at your desired time in this mode, use the “Timer” function to select the auto off timer.

8.3 Timer

Use this power-saving feature if you want the appliance to turn off automatically.

To select the Off time, press the “TIMER” button on the remote control or fan control panel once. It will advance to 1 hour as indicated by the number display, the “Timer” indicator symbol will illuminate and the fan will turn off after approximately 1 hour.

Each consecutive press of the “TIMER” button will advance the timer in 1-hour increments until it reaches a maximum time of 9 hours.

To reset to a new time, continue to press the “TIMER” button until it cycles back to where the hour number you desire is displayed.

After the Auto Off time has been set, the display will change back to the fan speed setting number and will then display the timer setting and Timer indicator light every 5 seconds.

To turn off the timer, continue to press the “TIMER” button until it cycles back to where “0” is displayed.

If you want to turn the fan off, Press the “ON/OFF” button.

8.4 Oscillating (Swing) Function

The fan is fitted with an Oscillating function where when activated, the fan head will swing from side to side.

Press the “OSC” button on the remote control or fan control panel to activate the oscillating function. The fan head will swing from side to side whilst blowing air.

To stop the oscillation at any direction, Press the “OSC” button again.

Note: Do Not force the head to rotate by hand. Always use the control buttons.

8.5 Using the Smart Phone App

Note: The Smart Home Pedestal Fan and TuyaSmart App only supports a 2.4GHz Wi-Fi network. It will not work on a 5GHz network.

- After pairing your fan and phone, and with the smart phone App open you can turn the fan on by pressing the “Switch” button at the bottom left of the screen.
- The fan will start in the default speed setting and in “Normal” mode. (refer to Modes in the section “Fan Modes” in this instruction manual to understand what the modes do).
- With the fan on, you can adjust the fan speed by either tapping on the speed slider or by dragging the slider to your desired position.

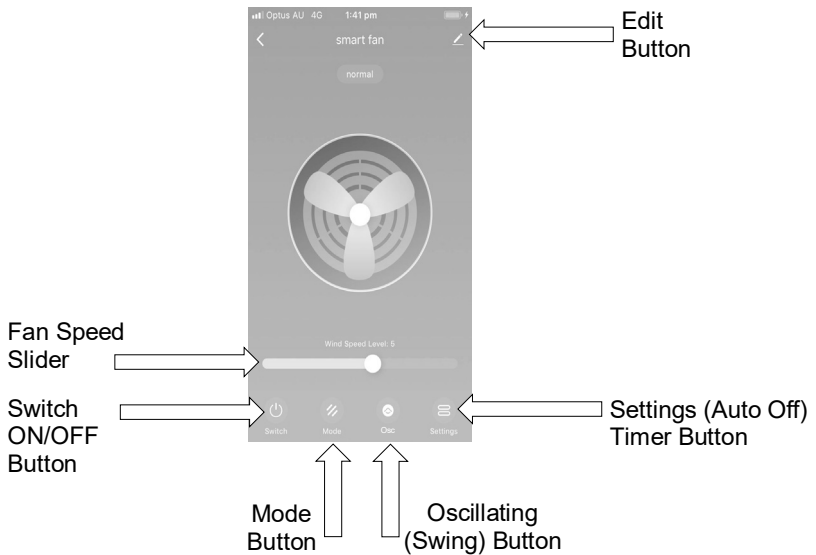

- You can select the Fan Mode you desire by pressing the “Mode” button at the bottom of the screen and then select which mode you desire. (refer to Modes in the section “Fan Modes” in this instruction manual to understand what the modes do).
- You can turn on the Fan Head Oscillating function by pressing the “Osc” button at the bottom of the screen. Refer to the Oscillating (Swing) Function section in this instruction manual for more information.
- By pressing the “Settings” button in the lower right corner, you will access the Auto Off timer (countdown timer). Here, you can select the hours until the fan automatically turns off. Refer to the “Timer” section in this instruction manual for more information.
- At the top right corner of the screen, there is a small icon of a Pencil. This is the Edit function. Press this and you can change the name of your fan, the fan location within your home and other settings including resetting or removing the fan from the App.

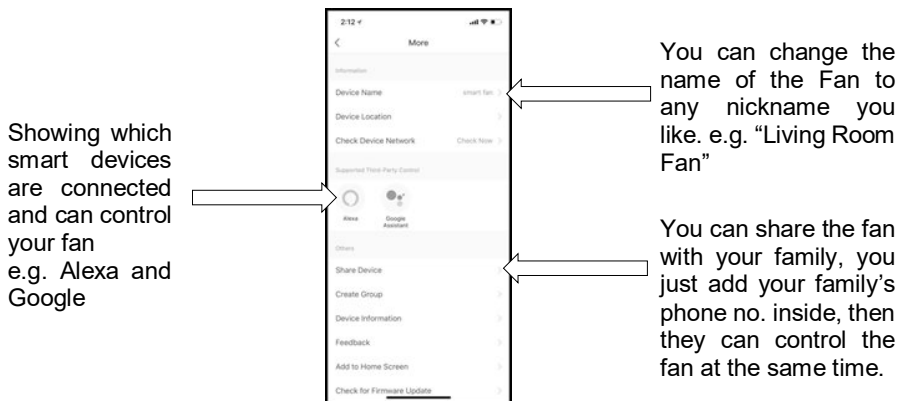

- The Smartphone App allows you to set the time to automatically switch the device On.

This is set up when the Fan is set to Off within the smartphone App.

When in the Off State, in the lower right corner of the screen, there is an icon “Countdown”.

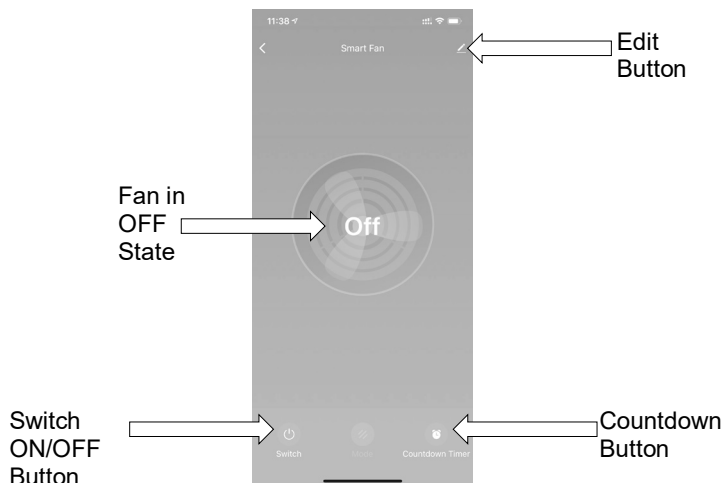

Press the Countdown button and it will open a selection from 1 to 9 hours.

Select the number in hours that you want your fan to turn on.

e.g. If you want your fan to turn on in 2 hours, press the number 2, then press the “Done” button.

Your fan will now turn on automatically in 2 hours.

Important: It is strongly recommended never to leave electrical appliance switched on or in use when not attended.

9 Using Google Home Device

Set up your Google Device as per the device’s instructions and make sure you meet the following conditions:

- You have a Google Home device, or Android phone with Google Assistant.
- Latest Google Home App.
- Latest Google App (Android only)
- You have set up a Google account
- The device display language must be set to English (Australian)
- TuyaSmart App and a registered account already set up.
- One Wi-Fi Fan

If you have not installed the Google Home App or the Google Assistant App. please do so by following the instructions in these apps.

9.1 Link TuyaSmart account in Google Home Control

ATTENTION: Due to the Google Home App's known bug, you could only use one Google account to control "Home Control Action". If you sign in to Google Home App with several Google accounts, only the first Google account you signed in with can be used for "Home Control".

Please also note that Google device will only turn the fan on and off, and set the fan speed. It cannot be used to operate all other functions.

- Open the Google Home App.
- Click the (account) button in the lower right corner.
- Scroll down and select "More Settings".
- Under the heading "ASSISTANT" select "Home Control", and then click the plus sign in the lower right corner.
- Scroll through the list to find TuyaSmart and the select it.
- Enter your TuyaSmart account phone number or email address and password (which is what you used to register in the TuyaSmart App), then tap "Link Now".
- Press "Authorize".
- You will see the Fan show up in the "Choose Device" page. Select the fan then press "Next"
- In the "Choose a Home" page, select your home or create a new home, then press "Next"
- Assign a room, or create a new room, to where the fan will be placed then press "Next"
- Your fan will now be listed in the Home page.

9.2 Control your Fan through Google Home

- Now you can control your smart devices through Google Home using three commands as follows:

To operate by voice, say in a clear precise voice:

Hey Google, turn on the Smart fan

Hey Google, turn off the Smart fan

Hey Google, set Smart fan to Speed 1~ 8 (speed from 1 to 8)

Please note the key words when you talk to Google device

"turn on"

"turn off"

set + device name (Smart Fan) + to + speed (one, two, three.....)

10 Using Amazon Echo Device

Set up your Amazon Echo Device as per the device's instructions and make sure you meet the following conditions:

- You have an Echo device, such as Echo, Echo Dot, Echo Plus, Echo Connect and Echo Spot.
- You have set up an Amazon account through Amazon Alexa App.
- TuyaSmart App and a registered account already set up.
- One Wi-Fi Fan

If you have not installed the Amazon Alexa App, please do so by following the instructions in the App.

- After you have set up and logged in to the Alexa App, whilst in the Home page, tap the hamburger menu icon on the top left corner.
- Select "Skills & Games"
- Tap the "Search" icon at the top right corner of the screen and type in **Tuya Smart**
- Select the Tuya Smart App then press "Enable to use"
- You will be redirected to the account link page. Enter your TuyaSmart account phone number or email address and password (which is what you used to register in the TuyaSmart App), then tap "Link Now".
- Press "Authorize". Then press "Done" and close the pages.

10.1 Control your Fan through Echo

Echo needs to discover your Fan before it controls it.

- You can say "Alexa, discover devices" to Echo and then follow the prompts from Alexa.
- Echo will discover devices which have already been added in the TuyaSmart App.
- In the Alexa App, in the Home page, tap the hamburger menu icon on the top left corner.
- Select "Add Devices"
- Scroll to the bottom of the list and select "Other", then press "Discover Devices"
- After the Device has been discovered, press "Set Up Device". You can either add to a group or skip this option.
- It will confirm that your device (Smart Fan) is ready to use. Press "Continue" then "Done".

Note: if you change the device's name on TuyaSmart App, Echo must re-discover before you can control them again

- Now you can control your smart devices through the Echo device using three commands as follows:

To operate by voice, say in a clear precise voice:

Alexa, turn on the Smart fan

Alexa, turn off the Smart fan

Alexa, set Smart fan to Speed 1~ 8 (speed from 1 to 8)

Please note the key words when you talk to the Echo device

“turn on”

“turn off”

set + device name (Smart Fan) + to + speed (one, two, three.....)

11 Shared Device

You can share the fan operation with your family, you just add your family members phone number inside the TuyaSmart phone App, then they can control the fan at the same time.

Refer to the section in this instruction manual “Using the Smart Phone App” and follow the instructions.

12 Care and Cleaning

- Ensure that the fan is switched off from the supply mains before removing the guard.
- Turn off and unplug the unit prior to cleaning.
- Clean the motor housing and body assembly with a clean, damp cloth and wipe dry.
- Never spray with liquids or submerge the Fan in water or any other liquid.
- Do not use flammable liquids, chemicals, abrasive creams, steel wool or scouring pads for cleaning.

13 Storage

Switch off and unplug the fan.

Coil the cable loosely. Do not kink or pull the cable tight.

Store your fan in a cool, dry location.

14 Troubleshooting

Will Not Switch On	Check that the power point is functional and that the Fan is fully plugged in and switched on.
No Wi-Fi Indicator Light either not rapidly blinking or not on permanently.	<p>If the Wi-Fi Indicator light does not turn on within 15 seconds of turning the power on to the fan, this would indicate that the Wi-Fi function has been turned off.</p> <p>To turn back on, Press the Knob on the Fan control panel to start the Fan, wait 5 seconds, then Press the Knob again to turn the Fan off, then Press the Knob again to start the Fan. The Wi-Fi will now stay on permanently.</p>
The Wi-Fi light blinks rapidly	<p>Fan is not Paired to your smartphone device.</p> <p>Refer to section "Wi-Fi Pairing" and follow the setup instructions.</p>
Fan turns On Automatically	<p>You have set the Auto On timer within the smartphone device.</p> <p>Refer to section "Using the Smart Phone App" for further instructions.</p>
Unable to connect to the Network	The Smart Home Pedestal Fan and TuyaSmart App only supports a 2.4GHz Wi-Fi network. It will not work on a 5GHz network.
Fan turns Off Automatically	<p>You have set the Auto Off timer either within the smartphone device, the remote control or on the Fan control Panel.</p> <p>Refer to section "Using the Smart Phone App" for further instructions.</p> <p>Refer to section "Operation" for further instructions.</p> <p>Refer to section "Timer" for further instructions.</p>
Unable to control some Fan functions using Google Device or Amazon Alexa Device.	<p>Only the Fan "On", "Off" and fan speed setting functions can be controller through these devices.</p> <p>Refer to section "Using Google Home Device" and "Using Amazon Alexa Device" for further information.</p>
Normal Remote Control does not function	<p>Ensure the batteries are installed the correct way around. e.g. Positive (+) is to Positive (+) and Negative (-) is to Negative (-).</p> <p>Ensure batteries are not flat or corroded.</p> <p>Replace with new batteries and ensure the battery contacts are clean.</p>

15 Warranty Against Defect

12 Month Warranty

Thank you for your purchase from Kmart.

Kmart Australia Ltd warrants your new product to be free from defects in materials and workmanship for the period stated above, from the date of purchase, provided that the product is used in accordance with accompanying recommendations or instructions where provided. This warranty is in addition to your rights under the Australian Consumer Law.

Kmart will provide you with your choice of a refund, repair or exchange (where possible) for this product if it becomes defective within the warranty period. Kmart will bear the reasonable expense of claiming the warranty. This warranty will no longer apply where the defect is a result of alteration, accident, misuse, abuse or neglect.

Please retain your receipt as proof of purchase and contact our Customer Service Centre 1800 124 125 (Australia) or 0800 945 995 (New Zealand) or alternatively, via Customer Help at Kmart.com.au for any difficulties with your product. Warranty claims and claims for expense incurred in returning this product can be addressed to our Customer Service Centre at 690 Springvale Rd, Mulgrave Vic 3170.

Our goods come with guarantees that cannot be excluded under the Australian Consumer Law. You are entitled to a replacement or refund for a major failure and compensation for any other reasonably foreseeable loss or damage. You are also entitled to have the goods repaired or replaced if the goods fail to be of acceptable quality and the failure does not amount to a major failure.

For New Zealand customers, this warranty is in addition to statutory rights observed under New Zealand legislation.

IMPORTANT!

For all technical queries or difficulties in operating the product and for spare parts, contact H.E. Group customer service 1300 105 888 (Australia) and 09 8870 447 (New Zealand).

