

Assembly Instruction







CARE INSTRUCTIONS:

WIPE CLEAN WITH A DAMP CLOTH. DO NOT USE ABRASIVE MATERIALS AND SOLVENTS. CHECK AND TIGHTEN ALL PARTS REGULARLY. STORE IN A DRY PLACE.

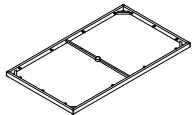
WARNING:

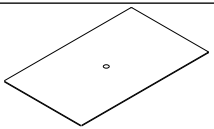
DO NOT PLACE VERY HOT OR VERY COLD ITEMS ON THE GLASS SURFACE UNLESS ADEQUATELY THICK TABLEMATS ARE USED TO PREVENT SUCH ITEMS FROM COMING INTO CONTACT WITH THE GLASS. DO NOT SIT OR STAND UPON THE GLASS SURFACE. DO NOT USE THE GLASS AS A CHOPPING SURFACE. DO NOT STRIKE THE GLASS WITH HARD OR POINTED ITEMS. WHEN CLEANING THE GLASS SURFACE USE A DAMP CLOTH WITH LIQUID DETERGENT OR A WINDOW CLEANER. DO NOT USE WASHING POWDER OR ANY OTHER SUBSTANCES CONTAINING ABRASIVES AS THESE MAY SCRATCH THE GLASS SURFACE. DO NOT USE THE TABLE UNLESS ALL BOLTS, SCREWS AND KNOBS ARE FIRML Y SECURED. USE ONLY ON EVEN SURFACE. FOR DOMESTIC USE ONLY. **MAXIMUM LOADING WEIGHT: 50KG.** FAILURE TO FOLLOW THESE WARNINGS COULD RESULT IN SERIOUS INJURY.

Hardware List

A		1PC	E		12PCS
B		1PC	F		12PCS
C		4PCS	G		1PC
D	 M6x15mm	12PCS			

Step 1

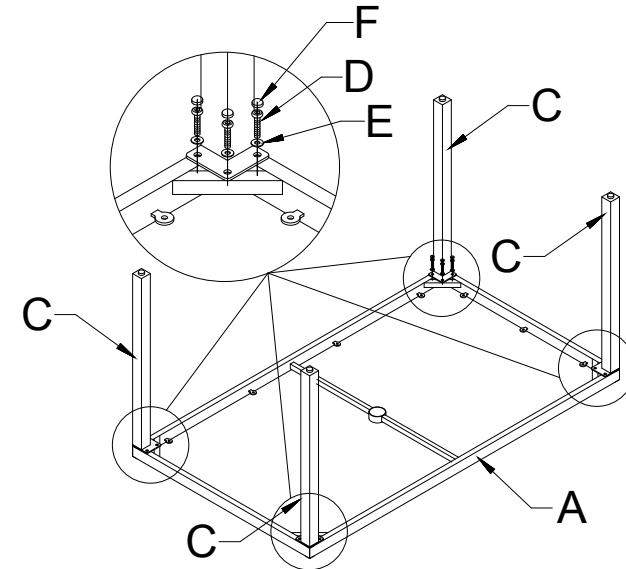

Step 2

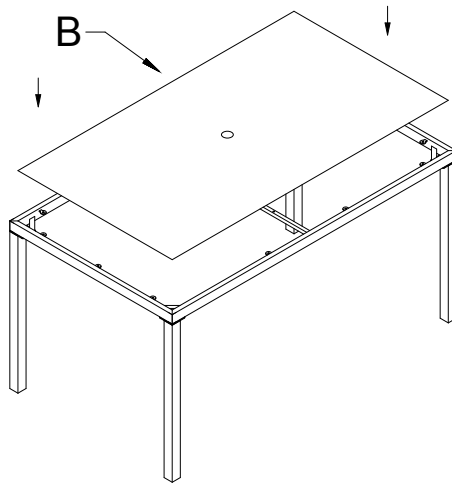

Step 3

