

TP387S

2 Storey Cubby House / Slide



Instructions for assembly, maintenance and safe use.

We constantly strive to improve our assembly instructions. To see the most current version of this instruction for assembly, maintenance and safe use. Please visit the product page at tptoys.com

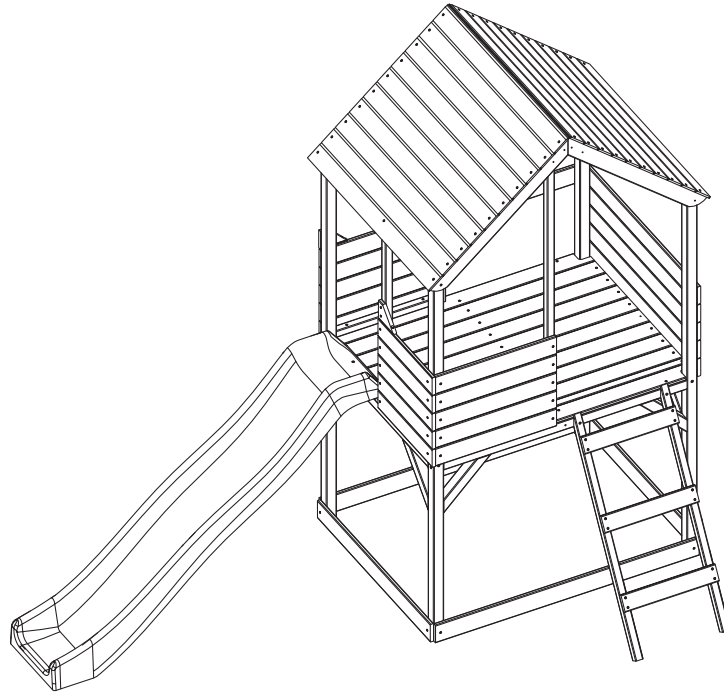

*Sand not Supplied

WARNINGS!

IT IS NOT SUITABLE FOR CHILDREN UNDER 36 MONTHS.
CONTAINS SMALL PARTS. CHOKING HAZARD.
ONLY FOR DOMESTIC USE.
FOR OUTDOOR USE ONLY.
TOY MUST BE ASSEMBLED BY AN ADULT BEFORE USE.
ADULT SUPERVISION IS REQUIRED.
CHILDREN MUST NOT USE THIS PRODUCT UNTIL PROPERLY
INSTALLED.
REMOVE ALL PACKAGING BEFORE GIVING TO YOUR
CHILDREN.

ANCHORS THAT ARE SUPPLIED WITH THIS PRODUCT MUST BE
FITTED BEFORE USE.

THIS PRODUCT IS INTENDED FOR USE BY CHILDREN FROM
AGES 3 AND UP.

MAXIMUM USERS : 3

MAXIMUM USER WEIGHT 50KGS.

A SUITABLE ENVIRONMENTALLY / CHILD FRIENDLY STAIN,
TREATMENT OR PAINT MUST BE USED

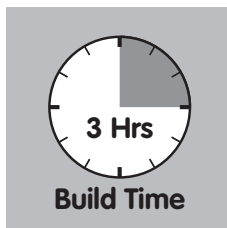
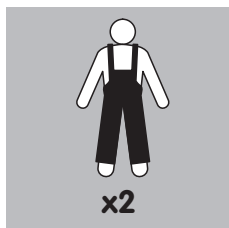

Robovision Ltd t/a TP Toys

Unit 11, Enterprise Way, Flitwick, Bedfordshire, MK45 5BX England

www.tptoys.com

EN**WARNINGS!**

IT IS NOT SUITABLE FOR CHILDREN UNDER 36 MONTHS.
CONTAINS SMALL PARTS. CHOKING HAZARD.
ONLY FOR DOMESTIC USE.
FOR OUTDOOR USE ONLY.
TOY MUST BE ASSEMBLED BY AN ADULT BEFORE USE.
ADULT SUPERVISION IS REQUIRED.
CHILDREN MUST NOT USE THIS PRODUCT UNTIL PROPERLY
INSTALLED.

REMOVE ALL PACKAGING BEFORE GIVING TO YOUR CHILDREN.
ANCHORS THAT ARE SUPPLIED WITH THIS PRODUCT MUST BE FITTED
BEFORE USE.
THIS PRODUCT IS INTENDED FOR USE BY CHILDREN FROM AGES 3
AND UP.
MAXIMUM USERS : 3
MAXIMUM USER WEIGHT 50KGS.
A SUITABLE ENVIRONMENTALLY / CHILD FRIENDLY STAIN,
TREATMENT OR PAINT MUST BE USED

Instructions for assembly, maintenance and safe use.

Please retain this information for future reference.

1. Toy must be assembled by an adult before use exactly in accordance with the instructions.
2. Children must not use this product until properly installed.
3. Check all parts are present before you start to assemble the product. Place small parts on a tray or similar to ensure they are not lost. The manufacturing process can very occasionally result in sharp edges/waste material so please take care when assembling this product.
4. If any parts are missing do not use the product until the replacement parts are fitted.
5. Ensure your product is sited on level ground. Failure to do this may put additional stress on connections and joints and in time could cause them to fail.
6. Ensure your product is located on a soft impact surface like grass. Never locate your product on hard surfaces like concrete.
7. Avoid locating this product in full sun.
8. Remove all packaging before giving to your children.
9. Equipment should be checked by an adult at the beginning of each season and at regular intervals during the usage season to ensure it is safe. Pay special attention to all connections and fastenings.
10. Parts may need to be replaced if they show signs of wear and tear. Replace any defective parts in accordance with these instructions.
11. Due to the natural characteristics of timber, it is vital to check your playframe regularly for splintering, lifting of surface layers of wood or exposure of rough wood. Affected areas must be rubbed down using coarse sandpaper to restore a smooth, safe surface.
12. Any changes to this toy eg changing or adding an accessory, must be done in accordance with our instructions. Failure to do this will render your guarantee null and void and may make your product unsafe.
13. Ensure children's clothing is appropriate for the play activity.
14. Never place toys near a fire.
15. In high winds, ensure outdoor toys are moved to a sheltered position and/or securely staked down.
16. The age recommendation for this product is clearly stated on the packaging and in these instructions. Please adhere to it at all times. Adult supervision is required at all times to ensure children play safely.
17. When you dispose of this equipment please do so responsibly.

FR**AVERTISSEMENT!**

RÉSERVÉ À UN USAGE DOMESTIQUE. POUR UNE UTILISATION
À L'EXTÉRIEUR SEULEMENT.
CE PRODUIT EST CONÇU POUR LES ENFANTS ÂGÉS DE 3 +
ANS.
AVANT USAGE, LE JOUET DOIT ÊTRE ASSEMBLÉ PAR UN
ADULTE CONFORMÉMENT AUX CONSIGNES.

CE PRODUIT NE DOIT PAS ÊTRE UTILISÉ PAR DES ENFANTS
TANT QU'IL N'EST PAS INSTALLÉ CORRECTEMENT.
À UTILISER SOUS LA SURVEILLANCE D'UN ADULTE.
TENIR ÉLOIGNÉ DU FEU.
RETIRER TOUT L'EMBALLAGE AVANT DE DONNER CE PRODUIT
À SON ENFANT.

Consignes d'assemblage, d'entretien et d'utilisation pour éviter le danger.

Veillez conserver ces informations afin de pouvoir vous y référer plus tard.

1. Les jeux doivent être assemblés par un adulte conformément aux consignes.
2. Ce produit ne doit pas être utilisé par des enfants tant qu'il n'est pas installé correctement
3. Vérifier que toutes les pièces sont présentes avant de commencer à assembler le produit. Placer les petites pièces sur un plateau ou autre pour veiller à ne pas les perdre. Le processus de fabrication peut, en de très rares occasions, engendrer des rebords tranchants/déchets ; il est donc nécessaire de faire attention au moment de l'assemblage de ce produit
4. S'il manque une pièce, ne pas utiliser le produit jusqu'à l'installation de la pièce de substitution
5. Veiller à installer le produit sur une surface plane. Sinon, cela risque d'exercer une pression trop importante sur les attaches et les jointures et de provoquer une chute au bout de quelque temps.
6. Veiller à ce que le produit soit situé sur une surface molle, comme de l'herbe. Never locate your product on a hard surfaces like concrete .
7. Éviter de placer ce produit en plein soleil.
8. Retirer tout l'emballage avant de donner ce produit à son enfant
9. L'installation doit être vérifiée par un adulte au début de chaque saison et à un intervalle régulier au fur et à mesure de son utilisation pendant la saison pour garantir que son utilisation est sûre. Faire bien attention à toutes les attaches et fixations
10. En cas d'usure, certaines pièces pourraient avoir à être remplacées. Remplacer toute pièce défectueuse conformément à ces consignes
11. En raison des caractéristiques naturelles du bois, il est essentiel de vérifier la structure du jeu régulièrement afin de s'assurer qu'il n'y ait pas d'éclats et que les couches supérieures ne se soulèvent pas ou que le bois brut ne soit pas exposé. Les zones touchées doivent être frottées avec du papier de verre à grain élevé afin de recréer une surface lisse et sûre
12. Toute modification apportée à ce jouet (changement ou ajout d'un accessoire, etc.) doit être effectuée conformément à nos consignes. Si ce point n'est pas respecté, cela pourrait entraîner la nullité de la garantie du produit et rendre le produit dangereux.
13. Veiller à ce que les vêtements de l'enfant soient appropriés pour jouer.
14. Ne jamais placer les jouets près d'un feu.
15. Lorsqu'il y a du vent, veiller à ce que les jouets soient placés à l'abri ou bien attachés au sol.
16. L'âge recommandé pour utiliser ce produit est indiqué clairement sur l'emballage et dans ces consignes. Veiller à les respecter à tout moment. La surveillance d'un adulte est requise à tout moment pour garantir que les enfants jouent en toute sécurité.
17. Jeter cet équipement de manière responsable.

DE ACHTUNG!

DIESES PRODUKT EIGNET SICH FÜR KINDER ZWISCHEN 3 + JAHRE.

NUR FÜR DEN HÄUSLICHEN GEBRAUCH. FÜR DRAUSSE.

DAS SPIELZEUG MUSS VOR GEBRAUCH VON EINEM ERWACHSENEN GENAU NACH ANLEITUNG ZUSAMMENGEBAUT WERDEN.

KINDER DÜRFEN DAS PRODUKT NICHT BENUTZEN, BEVOR ES NICHT KORREKT AUFGEBAUT WURD.

AUFSICHT DURCH EINEN ERWACHSENEN ERFORDERLICH. VON FEUER FERNHALTEN.

ALLE VERPACKUNGEN ENTFERNEN, BEVOR IHRE KINDER DAS PRODUKT ERHALTEN ODER DAMIT SPIELEN DÜRFEN.

Zusammenbau-, Wartungs- und Gebrauchsanweisungen.

Bitte diese Informationen zur späteren Bezugnahme aufbewahren.

1. Das Spielzeug muss vor Gebrauch von einem Erwachsenen genau nach Anleitung zusammengebaut werden.
2. Kinder dürfen das Produkt nicht benutzen, bevor es nicht korrekt aufgebaut wurde
3. Vor Zusammenbau des Produkts überprüfen, dass alle Teile vorhanden sind. Kleine Teile auf ein Tablett oder Ähnliches legen, damit sie nicht verloren gehen. Der Herstellungsprozess kann gelegentlich zu scharfen Kanten/Materialresten führen; seien Sie daher vorsichtig beim Zusammenbau dieses Produkts.
4. Sollten irgendwelche Teile fehlen, das Produkt nicht verwenden, bis die Ersatzteile angebracht wurden.
5. Sicherstellen, dass das Produkt auf ebenem Untergrund steht. Bei Nichtbeachtung können die Verbindungsteile und Gelenke zusätzlicher Belastung ausgesetzt werden und versagen.
6. Sicherstellen, dass Ihr Produkt auf weichem Boden wie Gras steht. Das Produkt niemals auf hartem Boden wie Beton aufstellen.
7. Diese Produkt nicht in der vollen Sonne aufstellen.
8. Alle Verpackungen entfernen, bevor Ihre Kinder das Produkt erhalten oder damit spielen dürfen.
9. Geräte sollte zu Beginn jeder Saison sowie regelmäßig während der Gebrauchssaison von einem Erwachsenen überprüft werden, um ihre Sicherheit zu gewährleisten. Besonders auf alle Verbindungen und Befestigungen achten.
10. Teile müssen bei Abnutzungserscheinungen u. U. ersetzt werden. Alle fehlerhaften Teile gemäß diesen Anleitungen ersetzen.
11. Aufgrund der natürlichen Eigenschaften von Holz ist es sehr wichtig, Ihren Spielrahmen regelmäßig auf Splitter sowie abgehobene Oberflächen und raues Holz zu überprüfen. Betroffene Bereiche mit grobem Schleifpapier abschmirlen, um wieder eine glatte, sichere Oberfläche zu schaffen.
12. Bei allen Abänderungen des Spielzeugs, z. B. Auswechselln oder Hinzufügen von Zubehör, unsere Anleitungen befolgen. Nichtbeachtung führt zum Erlöschen Ihrer Garantie und kann bedeuten, dass Ihr Produkt nicht länger sicher ist.
13. Für die Spielaktivität geeignete Kinderkleidung wählen.
14. Niemals Spielzeug in der Nähe von Feuer aufstellen.
15. Bei starkem Wind sicherstellen, dass Spielzeug für draußen an eine geschützte Position verlegt wird und/oder fest verankert ist.
16. Das empfohlene Alter für dieses Produkt ist deutlich auf der Verpackung und in diesen Anleitungen angegeben. Bitte sich stets daran halten. Aufsicht durch Erwachsene ist steht erforderlich, um die Sicherheit von Kindern beim Spielen zu gewährleisten.
17. Bitte dieses Gerät verantwortungsvoll entsorgen.

ES AVISO!

ESTE PRODUCTO ESTÁ DESTINADO A SER UTILIZADO POR NIÑOS DE ENTRE 3 + AÑOS DE EDAD.

SOLO ES APTO PARA USO DOMÉSTICO. PARA USO EN EXTERIORES.

EL JUGUETE DEBE MONTARLO UN ADULTO ANTES DE SU USO, SIGUIENDO LAS INSTRUCCIONES AL PIE DE LA LETR.A

LOS NIÑOS NO DEBEN UTILIZAR ESTE PRODUCTO HASTA QUE ESTÉ CORRECTAMENTE INSTALAD.O

ES NECESARIA LA SUPERVISIÓN DE UN ADULTO.

MANTENER ALEJADO DEL FUEGO.

RETIRAR TODO EL EMBALAJE ANTES DE ENTREGAR ESTE JUGUETE AL NIÑO O PERMITIR QUE JUEGUE CON ESTE PRODUCTO.

Instrucciones de montaje, mantenimiento y uso seguro.

Guardar esta información para poder consultarla en un futuro.

1. El juguete debe montarlo un adulto antes de su uso, siguiendo las instrucciones al pie de la letra
2. Los niños no deben utilizar este producto hasta que esté correctamente instalado
3. Compruebe que estén todas las piezas antes de empezar a montar el product. Ponga las piezas pequeñas en una bandeja o similar para evitar que se pierdan. El proceso de fabricación puede resultar a veces en bordes o material de desecho cortantes, por lo que se debe llevar cuidado al montar este producto.
4. Si falta alguna pieza, no utilizar el producto hasta que se hayan conseguido e instalado los repuestos correspondientes.
5. Asegúrese de situar el producto sobre un suelo nivelado. De lo contrario las conexiones y las juntas se someterán a una tensión excesiva y podrán fallar pasado un tiempo.
6. Asegúrese de situar el producto sobre una superficie que absorba los impactos, como el césped. No colocar nunca el producto sobre superficies duras como el hormigón.
7. Evite colocar este producto a pleno sol.
8. Retirar todo el embalaje antes de entregar este juguete al niño o permitir que juegue con este producto
9. El equipo deberá ser examinado por un adulto al principio de cada temporada, y a intervalos regulares durante la temporada de uso, para cerciorarse de que sea seguro. Prestar atención especialmente a todas las conexiones y fijaciones.
10. Es posible que haya que cambiar las piezas si muestran indicios de desgaste. Sustituir las piezas que estén dañadas o defectuosas de acuerdo con estas instrucciones.
11. Debido a las características naturales de la madera, es imprescindible revisar el armazón con regularidad por si estuviera astillado, se hubiera deslaminado la superficie de la madera, o hubieran quedado expuestas las asperezas. Las áreas afectadas deben lijarse con lija gruesa para restaurar la superficie y volver a dejarla lisa y segura.
12. Todos los cambios efectuados a este producto (p. ej. añadir un accesorio), deben llevarse a cabo de acuerdo con nuestras instrucciones. De lo contrario, la garantía quedará invalidada y es posible que no resulte seguro utilizar el producto.
13. Asegúrese de que los niños lleven ropa adecuada a la actividad.
14. No colocar nunca los juguetes cerca de hogueras o llamas.
15. Si hace mucho viento, traslade los juguetes de jardín a un sitio resguardado y/o sujételos al suelo.
16. La edad recomendada para este producto se indica claramente en el embalaje y en estas instrucciones. Observe esta recomendación en todo momento. Es necesaria la supervisión de un adulto en todo momento para garantizar que los niños jueguen de forma segura.
17. Retire y deseche el embalaje no deseado



AVVERTENZA!

QUESTO PRODOTTO È DESTINATO A BAMBINI DI ETÀ COMPRESA TRA I 3 + ANNI.

SOLO PER USO IN AMBIENTI DOMESTICI. PER USO IN AMBIENTI ESTERNI.

IL GIOCATTOLO DEVE ESSERE MONTATO DA UN ADULTO

PRIMA DELL'USO SEGUENDO ALLA LETTERA LE ISTRUZIONI. I BAMBINI POSSONO UTILIZZARE QUESTO PRODOTTO SOLO A INSTALLAZIONE AVVENUTA.

SI RICHIEDE LA SORVEGLIANZA DI UN ADULTO.

STAI LONTANO DAL FUOCO.

ELIMINARE LA CONFEZIONE PRIMA DI DARE IL GIOCATTOLO AI BAMBINI O PERMETTERE LORO DI UTILIZZARLO.

Istruzioni per il montaggio, la manutenzione e l'utilizzo sicuro.

Conservare queste informazioni per consultazioni future.

1. Il giocattolo deve essere montato da un adulto prima dell'uso seguendo alla lettera le istruzioni
2. I bambini possono utilizzare questo prodotto solo a installazione avvenuta
3. Verificare che tutte le parti siano presenti prima di iniziare a montare il prodotto. Posizionare le parti piccole su un vassoio o simile affinché non vengano perse. Durante il processo di produzione possono crearsi a volte bordi taglienti/materiali di scarto per cui si raccomanda di prestare la massima attenzione quando si monta il prodotto
4. In caso di parti mancanti, non utilizzare il prodotto finché non vengano montate le parti di ricambio
5. Assicurarsi che il prodotto sia posizionato in piano, altrimenti si rischia di provocare ulteriore pressione sui collegamenti e le articolazioni, che col tempo potrebbero cedere.
6. Assicurarsi che il prodotto sia posizionato su una superficie di impatto morbida, come l'erba. Non posizionare mai il prodotto su superfici dure, come il cemento.
7. Evitare di posizionare questo prodotto in pieno sole.
8. Eliminare la confezione prima di dare il giocattolo ai bambini o permettere loro di utilizzarlo
9. L'attrezzatura deve essere ispezionata da un adulto all'inizio di ogni stagione e a intervalli regolari durante la stagione d'uso per garantirne la sicurezza. Prestare particolare attenzione a tutti i collegamenti e gli agganci
10. Potrebbe essere necessario sostituire le parti se presentano segni di usura. Sostituire eventuali parti difettose in conformità a queste istruzioni
11. Per via delle caratteristiche naturali del legno, è essenziale ispezionare la struttura per controllare che non vi siano schegge, strati di legno superficiale staccati o legno grezzo esposto. Le aree interessate devono essere levigate con della carta vetrata per rendere la superficie liscia e sicura
12. Ogni modifica a questo giocattolo (ad es. la sostituzione o aggiunta di un accessorio) deve essere fatta in base alle nostre istruzioni. La mancata osservanza di queste istruzioni renderà nulla la garanzia e potrebbe compromettere la sicurezza del prodotto.
13. Assicurarsi che i bambini indossino abiti consoni al gioco.
14. Non posizionare mai i giocattoli vicino al fuoco.
15. In caso di forte vento, assicurarsi che i giocattoli siano in una posizione riparata e/o fissati al terreno in modo sicuro.
16. L'età raccomandata per questo prodotto è indicata chiaramente sulla confezione e in queste istruzioni. Rispettare sempre le indicazioni fornite. Si richiede sempre la sorveglianza di un adulto per accertarsi che i bambini giochino in modo sicuro.
17. Smaltire il prodotto in modo responsabile.



WAARSCHUWING!

DIT PRODUCT IS BEDOELD VOOR GEBRUIK DOOR KINDEREN VAN 3 + TJAAR OUD.

ALLEEN VOOR HUISHOUELIJK GEBRUIK. VOOR GEBRUIK BUITENSHUIS.

KINDEREN MOGEN DIT PRODUCT NIET GEBRUIKEN VOORDAT HET JUIST IS GEÏNSTALLEERD.

TOEZICHT DOOR EEN VOLWASSENE IS VEREIST.

PLAATS SPEELGOED NOOIT IN DE BUURT VAN OPEN VUUR.

VERWIJDER ALLE VERPAKKINGSMATERIAAL VOORDAT U HET PRODUCT AAN KINDEREN GEEFT OF ZE MET HET PRODUCT LAAT SPELEN.

Instructies voor montage, onderhoud en een veilig gebruik.

Berg deze aanwijzingen goed op, mocht u ze later willen raadplegen.

1. Het speelgoed moet door een volwassene worden gemonteerd in overeenstemming met de instructies voordat het mag worden gebruikt
2. Kinderen mogen dit product niet gebruiken voordat het juist is geïnstalleerd
3. Controleer of alle onderdelen aanwezig zijn voordat u begint met het monteren van het product. Plaats kleine onderdelen op een dienblad of vergelijkbaar oppervlak zodat ze niet kwijtraken. Het vervaardigingsproces kan er soms toe leiden dat er een scherp randje of afvalmateriaal achterblijft. Wees voorzichtig bij het monteren van dit product.
4. Als er onderdelen ontbreken, gebruik het product dan niet tot vervangende onderdelen zijn geplaatst.
5. Controleer of het product op een vlakke ondergrond is geplaatst. Als dit niet gebeurt, kunnen verbindings- en scharnierstukken onder meer druk komen te staan, waardoor ze in de loop der tijd kapot kunnen gaan.
6. Controleer of het product op een ondergrond met lage impact staat, zoals gras. Plaats het product nooit op een harde ondergrond als beton.
7. Plaats dit product niet in de volle zon.
8. Verwijder alle verpakkingsmateriaal voordat u het product aan kinderen geeft of ze met het product laat spelen
9. De apparatuur moet aan het begin van elk seizoen en periodiek tijdens gebruiksmomenten worden gecontroleerd om te waarborgen dat deze veilig is. Besteed extra aandacht aan alle verbindingen en bevestigingen
10. Als onderdelen tekenen van slijtage vertonen, kan het nodig zijn deze te vervangen. Vervang defecte onderdelen in overeenstemming met deze handleiding
11. Door de natuurlijke eigenschappen van hout is het belangrijk het frame van het speelgoed regelmatig te controleren op splinters, loslaten van oppervlakkige houtlagen of blootstelling van het ruwe hout. Betrokken gebieden moeten worden opgeruwd met ruw schuurpapier om het oppervlak te herstellen en het glad en veilig te maken
12. Enige wijziging aan dit speelgoed zoals het veranderen of toevoegen van toebehoren, moet worden uitgevoerd in overeenstemming met onze handleiding. Als dit niet gebeurt, komt de garantie te vervallen en kan het product onveilig worden.
13. Controleer of de kleding van kinderen geschikt is voor de spelactiviteit.
14. Plaats speelgoed nooit in de buurt van open vuur.
15. Zorg er bij harde wind voor dat speelgoed dat buiten staat opgesteld, op een beschermde locatie wordt geplaatst en/of veilig wordt verankerd.
16. De leeftijdsaanbeveling voor dit product staat duidelijk aangegeven op de verpakking en in deze handleiding. Houd u hier te allen tijde aan. Toezicht door volwassene(n) is te allen tijde vereist om te waarborgen dat kinderen veilig spelen.
17. Wanneer u deze apparatuur weggooit, doe dit dan op verantwoorde wijze.



Advertência!

ESTE PRODUTO DESTINA-SE A SER UTILIZADO POR CRIANÇAS DE IDADES COMPREENDIDAS ENTRE 3 + ANOS.

APENAS PARA USO DOMÉSTICO. PARA UTILIZAÇÃO EM ESPAÇOS EXTERIORES.

ANTES DA UTILIZAÇÃO, ESTE BRINQUEDO TEM DE SER MONTADO POR UM ADULTO EM EXATA CONFORMIDADE

COM AS INSTRUÇÕES.

AS CRIANÇAS NÃO DEVEM UTILIZAR ESTE PRODUTO ATÉ QUE ESTEJA DEVIDAMENTE MONTADO.

É NECESSÁRIO VIGILÂNCIA POR PARTE DE ADULTOS.

FIQUE LONGE DO FOGO.

RETIRE TODAS AS PEÇAS DE EMBALAGEM ANTES DE DAR ESTE PRODUTO À CRIANÇA OU DE PERMITIR QUE A CRIANÇA BRINQUE COM ELE.

Instruções de montagem, manutenção e utilização segura.

Retire todo o material de embalagem antes de dar este brinquedo à criança.

1. Antes da utilização, este brinquedo tem de ser montado por um adulto em exata conformidade com as instruções.
2. As crianças não devem utilizar este produto até que esteja devidamente montado.
3. Certifique-se de que todos os componentes estão presentes antes de iniciar a montagem do produto. Coloque as peças pequenas num tabuleiro ou recipiente semelhante para não as perder. O processo de fabrico pode resultar muito ocasionalmente em arestas afiadas/resíduos, pelo que deve ter cuidado ao montar este produto.
4. Se faltarem peças, não utilize o produto até que sejam montadas peças de substituição.
5. Certifique-se de que o produto é montado em piso nivelado. Caso contrário, as ligações e articulações poderão ser postas sob demasiada tensão e posteriormente falharem.
6. Certifique-se de que este produto é montado numa superfície de impacto suave, como um relvado. Nunca instale este produto em superfícies duras, como cimento.
7. Evite posicionar este produto à luz solar direta.
8. Retire todas as peças de embalagem antes de dar este produto à criança ou de permitir que a criança brinque com ele.
9. O equipamento deve ser verificado por um adulto no início de cada estação e a intervalos regulares durante a época de utilização para garantir o nível de segurança. Preste especial atenção a todas as ligações e fixações.
10. As peças poderão ter de ser substituídas se exibirem sinais de desgaste ou deterioração. Substitua todas as peças danificadas em conformidade com estas instruções.
11. Devido às características naturais da madeira, é vital verificar a estrutura regularmente quanto a fragmentação, elevação das camadas superficiais da madeira ou áreas de madeira áspera exposta. As áreas afetadas devem ser tratadas com uma lixa grossa de forma a restaurar a suavidade e segurança da superfície.
12. Qualquer alteração a este brinquedo, como mudança ou adição de acessórios, deverá ser feita em conformidade com as nossas instruções. O não cumprimento destas indicações invalidará a garantia e poderá reduzir o nível de segurança do produto.
13. Certifique-se de que o vestuário usado pelas crianças é adequado à atividade.
14. Nunca coloque brinquedos próximo de fogo.
15. Com ventos fortes, certifique-se de que os brinquedos de exterior são movidos para um local abrigado e/ou são devidamente escorados.
16. A recomendação etária relativa a este produto está claramente identificada na embalagem e nestas instruções. Cumpra-a de forma estrita. Para garantir que as crianças brincam em segurança, é necessário que sejam sempre supervisionadas por adultos.
17. Quando eliminar este produto, faça-o de forma responsável.



WARNUNG!

TEN PRODUKT PRZEZNACZONY JEST DLA DZIECI W WIEKU OD 3 + LAT.

TYLKO DO UŻYTKU DOMOWEGO. DO UŻYTKU W DOMU.

PRZED UŻYCIEM ZABAWKA MUSI BYĆ ZŁOŻONA PRZEZ DOROSŁEGO DOKŁADNIE WEDŁUG INSTRUKCJI.

DZIECIOM NIE WOLNO UŻYWAĆ TEGO PRODUKTU PRZED ODPOWIEDNIM MONTAŻEM.

WYMAGANY DOZÓR DOROSŁEGO.

NIGDY NIE NALEŻY UMIESZCZAĆ ZABAWEK BLISKO OGNIA.

ZANIM DASZ LUB POZWOLISZ DZIECIOM NA ZABAWĘ TYM PRODUKTEM, USUŃ WSZYSTKIE CZĘŚCI OPAKOWANIA.

Instrukcje dotyczące montażu, konserwacji oraz bezpiecznego użytkowania.

Informacje należy zachować do wykorzystania w przyszłości.

1. Przed użyciem zabawka musi być złożona przez dorosłego dokładnie według instrukcji.
2. Dzieciom nie wolno używać tego produktu przed odpowiednim montażem.
3. Przed rozpoczęciem montażu produktu, sprawdź, czy są wszystkie części. Wyłóż małe części na tacy lub czymś podobnym, żeby się nie zgubiły. W związku z procesem produkcji w nielicznych przypadkach produkt może zawierać ostre krawędzie/odpady, a więc należy zachować ostrożność podczas montażu tego produktu.
4. Jeśli brakuje jakiś części, nie używaj tego produktu, aż części zamiennie zostaną zamocowane.
5. Produkt powinien być ułożony na równej powierzchni. W innym razie połączenia i przeguby mogą być dodatkowo obciążone i z czasem mogą zepsuć się.
6. Produkt powinien stać na miękkiej powierzchni, np. na trawie. Nigdy nie należy umieszczać produktu na twardej powierzchni, takiej jak beton.
7. Należy unikać umieszczania tego produktu w pełnym słońcu.
8. Zanim dasz lub pozwolisz dzieciom na zabawę tym produktem, usuń wszystkie części opakowania.
9. Dorosły powinien sprawdzić sprzęt każdorazowo przed rozpoczęciem zabawy oraz w regularnych odstępach czasu w sezonie korzystania z tego sprzętu, aby zapewnić bezpieczeństwo. Zwróć szczególną uwagę na wszystkie połączenia i zapięcia.
10. Jeśli części mają oznaki zużycia, mogą wymagać wymiany.
11. Wszelkie uszkodzone części należy wymienić zgodnie z instrukcjami.
12. Ze względu na naturalne cechy drewna, należy regularnie sprawdzać, czy w konstrukcji z belek doszło do rozszczepiania fragmentów drewna, podnoszenia się wierzchnich warstw drewna lub powierzchnia drewna jest nierówna. Takie części należy wyrównać gruboziarnistym papierem ściernym, aby przywrócić gładką powierzchnię, która będzie bezpieczna w użytkowaniu.
13. Dokonywanie wszelkich zmian w tej zabawce, np. wymiana lub dodawanie akcesoriów powinno być wykonywane zgodnie z tymi instrukcjami. W przypadku niezastosowania się, gwarancja zostaje unieważniona, a produkt może nie być bezpieczny do użytku.
14. Należy zadbać, aby odzież dzieci była odpowiednia do danej zabawy.
15. Nigdy nie należy umieszczać zabawek blisko ognia.
16. Przy dużym wietrze zabawki, z których korzysta się na zewnątrz, należy przenieść do osłoniętego miejsca oraz/lub odpowiednio je przymocować.
17. Zalecenia odnośnie grupy wiekowej, dla której przeznaczony jest ten produkt są jasno określone na opakowaniu i w tych instrukcjach. Należy zawsze stosować się do nich. Przez cały czas wymagany jest dozór osoby dorosłej, aby dopilnować, że dzieci bawią się bezpiecznie.
18. Jeśli chcesz wyrzucić ten produkt, zrób to w sposób odpowiedzialny.

USA Warnings

THIS PRODUCT IS NOT SUITABLE FOR CHILDREN UNDER 36 MONTHS.
CONTAINS SMALL PARTS. CHOKING HAZARD.
ONLY FOR DOMESTIC USE. FOR OUTDOOR USE.
TOY MUST BE ASSEMBLED BY AN ADULT BEFORE USE.
ADULT SUPERVISION IS REQUIRED.
CHILDREN MUST NOT USE THE EQUIPMENT UNTIL PROPERLY INSTALLED.
REMOVE ALL PACKAGING BEFORE GIVING TO YOUR CHILDREN.

ANCHORS THAT ARE SUPPLIED WITH THIS PRODUCT MUST BE FITTED BEFORE USE.
KEEP AWAY FROM FIRE.
PLEASE RETAIN INSTRUCTIONS AS IT CONTAINS IMPORTANT SAFETY INFORMATION.
THIS PRODUCT IS INTENDED FOR USE BY CHILDREN FROM AGES 3 YEARS +.

USA Important advice for assembly, maintenance and safe use

1. Toy must be assembled by an adult before use exactly in accordance with the instructions.
2. Children must not use this product until properly installed.
3. Check all parts are present before you start to assemble the product. Place small parts on a tray or similar to ensure they are not lost. The manufacturing process can very occasionally result in sharp edges/waste material so please take care when assembling this product.
4. If any parts are missing do not use the product until the replacement parts are fitted.
5. Ensure your product is sited on level ground. Failure to do this may put additional stress on connections and joints and in time could cause them to fail.
6. Ensure your product is located on a soft impact surface like grass. Never locate your product on a hard surfaces like concrete.
7. Anchors supplied with this product must be fitted before use.
8. In freezing weather, detachable plastic parts should be stored inside.
9. Avoid locating this product in full sun.
10. Remove all packaging before giving to your children or allowing them to play with this product.
11. Equipment should be checked by an adult at the beginning of each season and at regular intervals during the usage season to ensure it is safe. Pay special attention to all connections and fastenings.
12. Parts may need to be replaced if they show signs of wear and tear. Replace any defective parts in accordance with these instructions.
13. With swings, particular attention should be paid to suspensions systems, ropes and all fixings. Ropes degrade over time and should be replaced as required.
14. Any changes to this toy including changing or adding an accessory, must be done in accordance with our instructions. Failure to do this will render your guarantee null and void and may make your product unsafe.
15. Ensure children's clothing is appropriate for the play activity.
16. Never place toys near a fire.
17. Take care in wet weather. Toys can become slippery.
18. In high winds, ensure outdoor toys are moved to a sheltered position and/or securely staked down.
19. The age recommendation for this product is clearly stated on the packaging and in these instructions. Please adhere to it at all times. Adult supervision is required at all times to ensure children play safely.

20. When you dispose of this equipment please do so responsibly
21. Owner to disassemble and dispose of the playground equipment in such a way that no unreasonable hazards will exist at the time the playground equipment is discarded..

Safe play free space area

The Safe Play Area refers to the zone extending 200cm beyond the toy on all sides and 2.5m above the toy. The Safe Play Area must be free from all structures, landscaping, trees and branches, rocks, wires, sprinkler heads and other similar obstacles to safe play. Children can be seriously injured running or colliding into such obstacles.

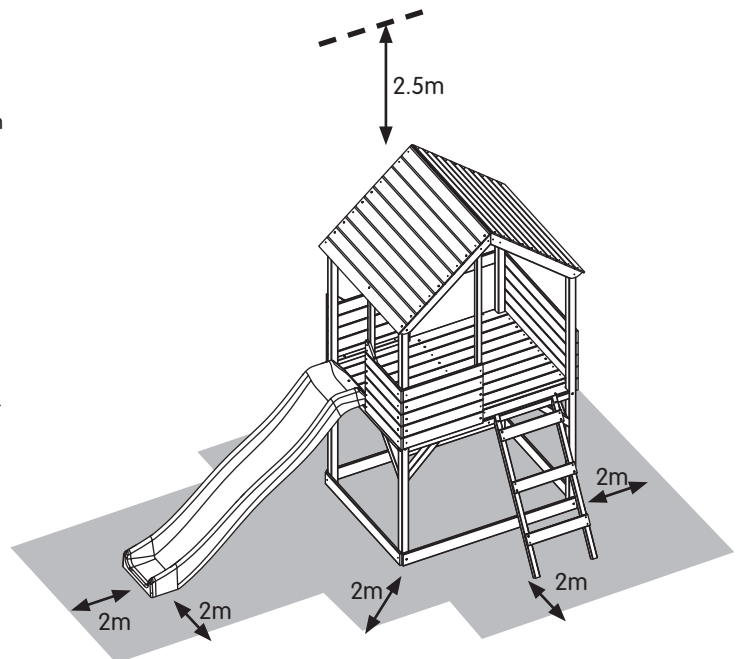

USA CONSUMER INFORMATION SHEET FOR PLAYGROUND SURFACING MATERIALS

The U.S. Consumer Product Safety Commission (CPSC) estimates that about 100 000 playground equipment related injuries resulting from falls to the ground surface are treated annually in U.S. hospital emergency rooms. Injuries involving this hazard pattern tend to be among the most serious of all playground injuries, and have the potential to be fatal, particularly when the injury is to the head. The surface under and around playground equipment can be a major factor in determining the injury-causing potential of a fall. It is self evident that a fall onto a shock absorbing surface is less likely to cause a serious injury than a fall onto a hard surface.

Playground equipment should never be placed on hard surfaces such as concrete or asphalt and while grass may appear to be acceptable it may quickly turn to hard packed earth in areas of high traffic. Shredded bark mulch, wood chips, fine sand or fine gravel are considered to be

acceptable shock absorbing surfaces when installed and maintained at a sufficient depth under and around playground equipment.

X3.1 Select Protective Surfacing - One of the most important things you can do to reduce the likelihood of serious head injuries is to install shock-absorbing protective surfacing under and around your play equipment. The protective surfacing should be applied to a depth that is suitable for the equipment height in accordance with ASTM Specification F 1292. There are different types of surfacing to choose from; whichever product you select, follow these guidelines:

X3.1.1 Loose-Fill Materials:

X3.1.1.1 Maintain a minimum depth of 9 inches of loose fill materials such as wood mulch/chips, engineered wood fiber (EWF), or shredded/ recycled rubber mulch for equipment up to 8 feet high; and 9 inches of sand or pea gravel for equipment up to 5 feet high. NOTE: An initial fill level of 12 inches will compress to about a 9- inch depth of surfacing over time. The surfacing will also compact, displace, and settle, and should be periodically refilled to maintain at least a 9-inch depth.

X3.1.2 Use a minimum of 6 inches of protective surfacing for play equipment less than 4 feet in height. If maintained properly, this should be adequate. (At depths less than 6 inches, the protective material is too easily displaced or compacted.)

NOTE: Do not install home playground equipment over concrete, asphalt, or any other hard surface. A fall onto a hard surface can result in serious injury to the equipment user. Grass and dirt are not considered protective surfacing because wear and environmental factors can reduce their shock absorbing effectiveness. Carpeting and thin mats are generally not adequate protective surfacing. Ground level equipment – such as a sandbox, activity wall, playhouse or other equipment that has no elevated play surface – does not need any protective surfacing.

X3.1.3 Use containment, such as digging out around the perimeter and/ or lining the perimeter with landscape edging. Don't forget to account for water drainage.

X3.1.3.1 Check and maintain the depth of the loose-fill surfacing material. To maintain the right amount of loose- fill materials, mark the correct level on play equipment support posts. That way you can easily see when to replenish and/or redistribute the surfacing.

X3.1.3.2 Do not install loose fill surfacing over hard surfaces such as concrete or asphalt.

X3.1.4 Poured-In-Place Surfaces or Pre-Manufactured Rubber Tiles - You may be interested in using surfacing other than loose-fill materials – like rubber tiles or poured-in-place surfaces.

X3.1.4.1 Installations of these surfaces generally require a professional and are not "do-it-yourself" projects.

X3.1.4.2 Review surface specifications before purchasing this type of surfacing. Ask the installer/manufacturer for a report showing that the product has been tested to the following safety standard: ASTM F 1292 Standard Specification for Impact Attenuation of Surfacing Materials within the Use Zone of Playground Equipment. This report should show the specific height for which the surface is intended to protect against serious head injury. This height should be equal to or greater than the fall height – vertical distance between a designated play surface (elevated surface for standing, sitting, or climbing) and the protective surfacing below – of your play equipment.

X3.1.4.3 Check the protective surfacing frequently for wear.

X3.1.5 Placement - Proper placement and maintenance of protective surfacing is essential. Be sure to:

X3.1.5.1 Extend surfacing at least 6 feet from the equipment in all directions.

X3.2 Table X3.1 lists the maximum height from which a child would not be expected to sustain a life-threatening head injury in a fall onto four different loose-fill surfacing materials if they are installed and maintained at depths of 6, 9, and 12 in. However, it should be recognized that all injuries due to falls cannot be prevented no matter what surfacing material is used.

X3.3 It is recommended that a shock absorbing material should extend a minimum of 6 ft in all directions from the perimeter of stationary equipment such as climbers and slides. However, because children may deliberately jump from a moving swing, the shock absorbing material should extend in the front and rear of a swing a minimum distance of 2 times the height of the pivot point measured from a point directly beneath the pivot on the supporting structure.

X3.4 This information is intended to assist in comparing the relative shock-absorbing properties of various materials. No particular material is recommended over another. However, each material is only effective when properly maintained. Materials should be checked periodically and replenished to maintain correct depth as determined necessary for your equipment. The choice of a material depends on the type and height of the playground equipment, the availability of the material in your area, and its cost.

9 This information has been extracted from the CPSC publications "Playground Surfacing -Technical Information Guide" and "Handbook for Public Playground Safety." Copies of these reports can be obtained by sending a postcard to the: Office of Public Affairs, U.S. Consumer Product Safety Commission, Washington, D.C., 20207 or call the toll-free hotline: 1-800-638-2772.

TABLE X3.1

Fall Height in Feet From Which a Life Threatening Head Injury Would Not Be Expected

Type of Material	6 inch. depth	9 inch. depth	12 inch. depth
Double Shredded Bark Mulch	6	10	11
Wood Chips	6	7	12
Fine Sand	5	5	9
Fine Gravel	6	7	10

(Maximum fall height for product = 102cm)

Warning

Please instruct children not to use the equipment in a manner other than intended.

Installation Instructions and Information -

Place the equipment on level ground, not less than 6ft (1.8m) from any structure or obstruction such as a fence, Garage, house, overhanging branches, laundry lines, or electrical wires.

Do not install home playground equipment over concrete, asphalt, packed earth, or any other hard surface. A fall onto a hard surface can result in serious injury to the equipment user.

Operating Instructions -

Observing the following statements and warnings reduces the likelihood of serious or fatal injury.

We recommend on-site adult supervision for children of all ages Instruct children not to walk close to, in front of, behind, or between moving items.

Instruct children not to twist swing chains or ropes or loop them over the top support bar since this may reduce the strength of the chain or rope.

Instruct children to avoid swinging empty seats.

Teach children to sit in the center of the swings with their full weight on the seats.

Instruct children not to use the equipment in a manner other than intended.

Instruct children not to get off equipment while it is in motion.

Parent to dress children appropriately (examples would include the use of well-fitting shoes and the avoidance of ponchos, scarfs, and other loose-fitting clothing that is potentially hazardous while using equipment).

Instruct children not to climb when the equipment is wet.

Check the openings between rollers and sliding surfaces of roller slides for foreign materials that could be potentially hazardous to users.

Verify that suspended climbing ropes, chain, or cable cannot be looped back on itself.

Instruct children not to attach items to the playground equipment that are not specifically designed for use with the equipment, such as, but not limited to, jump ropes, clothesline, pet leashes, cables and chain as they may cause a strangulation hazard.

Warning! the buyer to instruct children to remove their bike or other sports helmet before playing on the playground equipment.

WARNING: Lawn swings are designed for use by children two years of age and older. The use by children under the age of two can result in entrapment between the seat and back rest because the child's body may pass through the opening, causing entrapment of the child's head. Such entrapment may result in strangulation. **NEVER** place children in a rearward facing position or with legs between the seat and backrest.

Maintenance Instructions -

At the beginning of each play season:

Tighten all hardware. Lubricate all metallic moving parts per manufacturer's instructions.

Check all protective coverings on bolts, pipes, edges, and corners. Replace if they are loose, cracked, or missing. Check all moving parts including swing seats, ropes, cables, and chains for wear, rust, or other deterioration. Replace as needed. Check metal parts for rust. If found, sand and repaint using a non lead-based paint meeting the requirements of 16 CFR 1303.

Check all wood members for deterioration and splinters. Sand down splinters and replace deteriorating wood members. Reinstall any plastic parts, such as swing seats or any other items that were removed for the cold season. Rake and check depth of loose fill protective surfacing materials to prevent compaction and to maintain appropriate depth. Replace as necessary.

Twice a month during play season:

Tighten all hardware. Check all protective coverings on bolts, pipes, edges, and corners. Replace if they are loose, cracked, or missing. Rake and check depth of loose fill protective surfacing materials to prevent compaction and to maintain appropriate depth. Replace as necessary.

Once a month during play season:

Lubricate all metallic moving parts per manufacturer's instructions.

Check all moving parts including swing seats, ropes, cables, and chains for wear, rust, or other deterioration. Replace as needed.

At the end of each play season or when the temperature drops below 40°F (4°C). Remove plastic swing seats and other items as specified by the manufacturer and take indoors or do not use. Rake and check depth of loose fill protective surfacing materials to prevent compaction and to maintain appropriate depth. Replace as necessary.

تحذير!



AR

بدقة.
يُنصح استخدام الأطفال لهذا المنتج حتى يتم تركيبه بالشكل الصحيح.
يلزم وجود إشراف من شخص بالغ.
لا توضع الألعاب بالقرب من النيران أبدًا.
قم بإزالة جميع أغلفة اللعبة قبل إعطائها لأطفالك أو السماح لهم باللعب بها.

ويهدف هذا المنتج للاستخدام من قبل الأطفال الذين تتراوح أعمارهم بين 3+ سنوات.
للاستخدام المنزلي فقط.
للاستخدام في الأماكن المفتوحة.
يجب أن يقوم شخص بالغ بتركيب اللعبة قبل الاستخدام متبعًا للتعليمات

تعليمات التركيب والصيانة والاستخدام الآمن

يرجى الاحتفاظ بهذه المعلومات للرجوع إليها في المستقبل.

يجب أن يقوم شخص بالغ بتركيب اللعبة قبل الاستخدام متبعًا للتعليمات بدقة

يُنصح استخدام الأطفال لهذا المنتج حتى يتم تركيبه بالشكل الصحيح

تحقق من وجود جميع الأجزاء قبل البدء في تركيب المنتج

ضع الأجزاء الصغيرة على صينية أو ما شابه لضمان عدم فقدانها.

أحيانًا ما تتسبب عملية التصنيع في وجود حواف حادة/نفايات، لذا يرجى توخي الحذر عند تركيب هذا المنتج

في حالة فقدان أي جزء من الأجزاء لا تستخدم المنتج إلى أن يتم تركيب الأجزاء البديلة.

تأكد من وضع المنتج على أرضٍ مستوية. فقد يؤدي عدم القيام بذلك إلى ضغط إضافي على الروابط والمفصلات ومع الوقت قد يؤدي ذلك إلى تلفها.

تأكد من وضع المنتج على سطح أملس آمن مثل الأعشاب.

لا توضع المنتج على أسطح صلبة مثل الخرسانة.

تجنب وضع هذا المنتج أمام أشعة الشمس المباشرة.

قم بإزالة جميع أغلفة اللعبة قبل إعطائها لأطفالك أو السماح لهم باللعب بها

يجب على أحد الأشخاص البالغين فحص الأجهزة في بداية كل موسم وعلى فترات منتظمة خلال موسم الاستخدام للتأكد من سلامتها

يجب توجيه اهتمام خاص بجميع الوصلات والمثبتات

فقد يلزم استبدال الأجزاء في حالة ظهور علامات على تأكلها وتلفها. استبدل أي أجزاء معيبة وفقًا لهذه التعليمات

من المهم فحص إطار اللعب بانتظام للتأكد من عدم وجود تشققات أو رفع لطبقات الخشب السطحية أو انكشاف الخشب الخشن، بسبب الخصائص الطبيعية للأخشاب.

يجب فرك المناطق المتضررة باستخدام صنفرة خشنة لاستعادة السطح الأملس الآمن

يجب إجراء أي تغييرات على هذه اللعبة، مثل تغيير أحد الملحقات أو إضافته، وفقًا لتعليماتنا. وعدم الالتزام بذلك سيلغي الضمان الذي حصلت عليه ويبطئه وقد يؤدي إلى عدم سلامة المنتج.

تأكد من أن ملابس الأطفال تناسب مع نشاط اللعب.

في حالة هبوب رياح عاتية، تأكد من نقل الألعاب الخارجية إلى أماكن محمية و/أو تثبيتها بشكل محكم.

العمر الموصى به لاستخدام هذا المنتج مدون بوضوح على الغلاف وفي هذه التعليمات. يرجى الالتزام به طوال الوقت.

يلزم وجود إشراف دائم من الكبار لضمان لعب الأطفال بأمان.

عند التخلص من هذا الجهاز، يرجى القيام بذلك بطريقة مسؤولة.

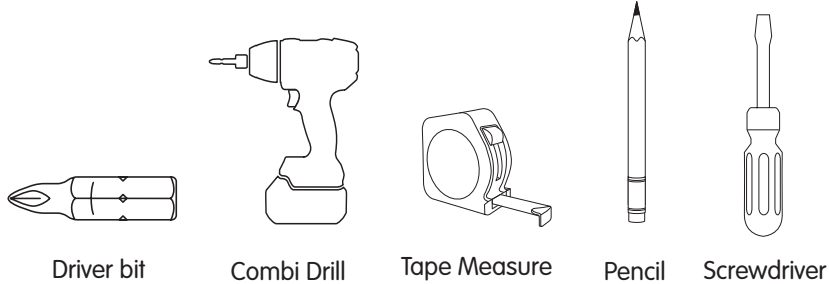

NOT INCLUDED

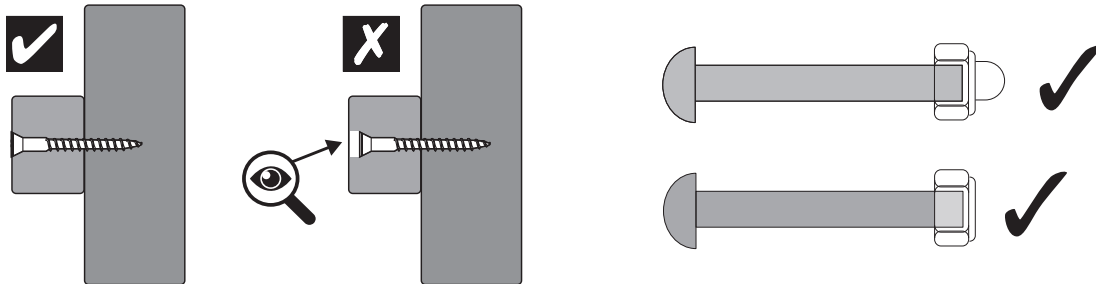



IMPORTANT WARNING

It is essential that this product has an application of a suitable child/environmentally friendly wood treatment before being assembled. Treat all panels - on all sides.

Mise en garde importante ! - Il est essentiel d'appliquer sur ce produit un traitement pour le bois respectueux de l'environnement et des enfants avant de le monter. Traiter tous les panneaux de chaque côté.

Avvertenza importante! - È essenziale che prima di essere assemblato questo prodotto sia sottoposto a trattamento del legno ecocompatibile/adatto ai bambini. Trattare tutti i pannelli - da ogni lato

¡Advertencia importante! - Es fundamental aplicar a este producto una capa de tratamiento para madera apto para niños y respetuoso con el medio ambiente. Trate todos los paneles, por todos sus lados.

Wichtige Warnung! - Es ist überaus wichtig, dass dieses Produkt vor der Montage mit einem geeigneten kinder- und umweltfreundlichen Holzschutzmittel behandelt wird. Behandeln Sie alle Teile an allen Seiten

Aviso importante! - É essencial que este produto receba uma aplicação de tratamento ecológico/seguro para crianças antes da sua montagem. Trate todos os painéis de todos os lados

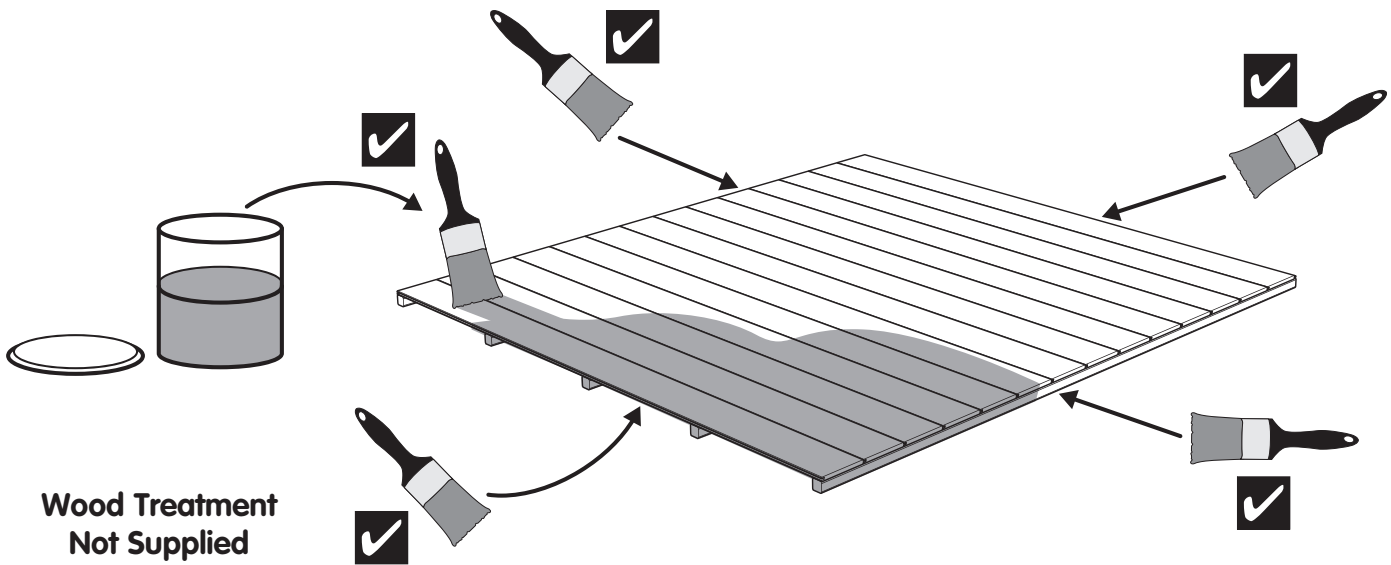

Wood Treatment Not Supplied

(non fournis)
(non in dotazione)
(no suministradas)
(nicht enthalten)
(não incluídas)

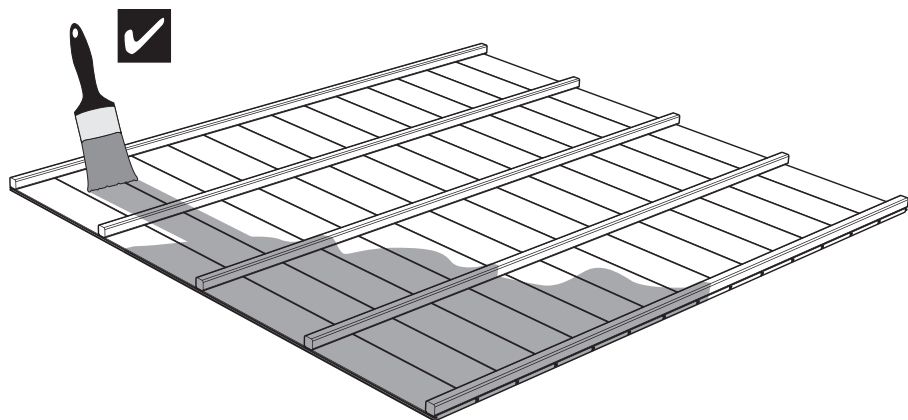

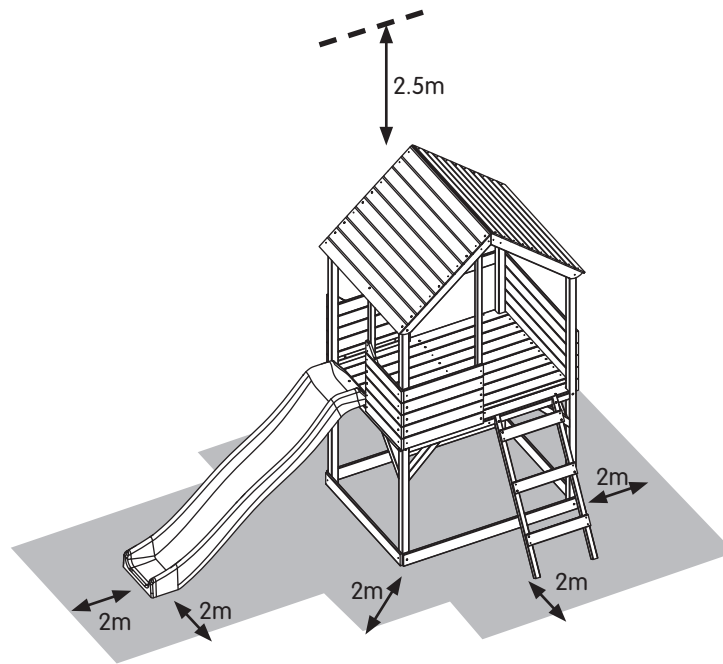

EN

The safe play area refers to the zone extending 200cm around the toys on all sides and 250 cm above the toy. The safe play area must be free from all obstacles.

ES

El término zona segura de juego hace referencia a la zona que abarca un radio de 200 cm en torno al juguete y 250 cm por encima del juguete. La zona segura de juego debe estar despejada y libre de todo obstáculo.

PL

A área de segurança refere-se à zona que se estende 200 cm para todos os lados para além do brinquedo e 250 cm acima do brinquedo. A área livre não deve conter qualquer obstáculo.

FR

L'espace de sécurité se rapporte à la zone de 200 cm qui s'étend de tous les côtés autour des jeux et à la zone de 250 cm qui s'étend au-dessus du jeu. L'espace de sécurité doit être libre.

IT

L'area di gioco sicura si riferisce alla zona che si estende per 200 cm su tutti i lati attorno all'insieme da gioco e per 250 cm sopra l'apparato. L'area di gioco sicura deve essere priva di ostacoli.

PT

Wolna przestrze bezpiecznej zabawy to strefa 200 cm wkoło zabawki oraz 250 cm nad zabawką. W wolnej przestrzeni bezpiecznej zabawy nie powinno byadnych przeszkód.

DE

Der sichere Spielbereich bezieht sich auf eine Zone von 200 cm rund um das Spielzeug sowie 250 cm oberhalb des Spielzeugs. Der sichere Spielbereich muss frei von allen Hindernissen sein.

NL

Het veilige speelgebied betreft de zone die zich 2 meter aan alle zijden rond de speeltoestellen bevindt en 2,5 meter boven het speeltoestel. Het veilige speelgebied moet vrij zijn van enig obstakel.

AR

تشير منطقة اللعب الآمن إلى المنطقة التي تمتد 200 سم حول الألعاب من جميع الجوانب و250 سم فوق الألعاب. يجب أن تكون منطقة اللعب الآمن خالية من أي عوائق.

Dimensions

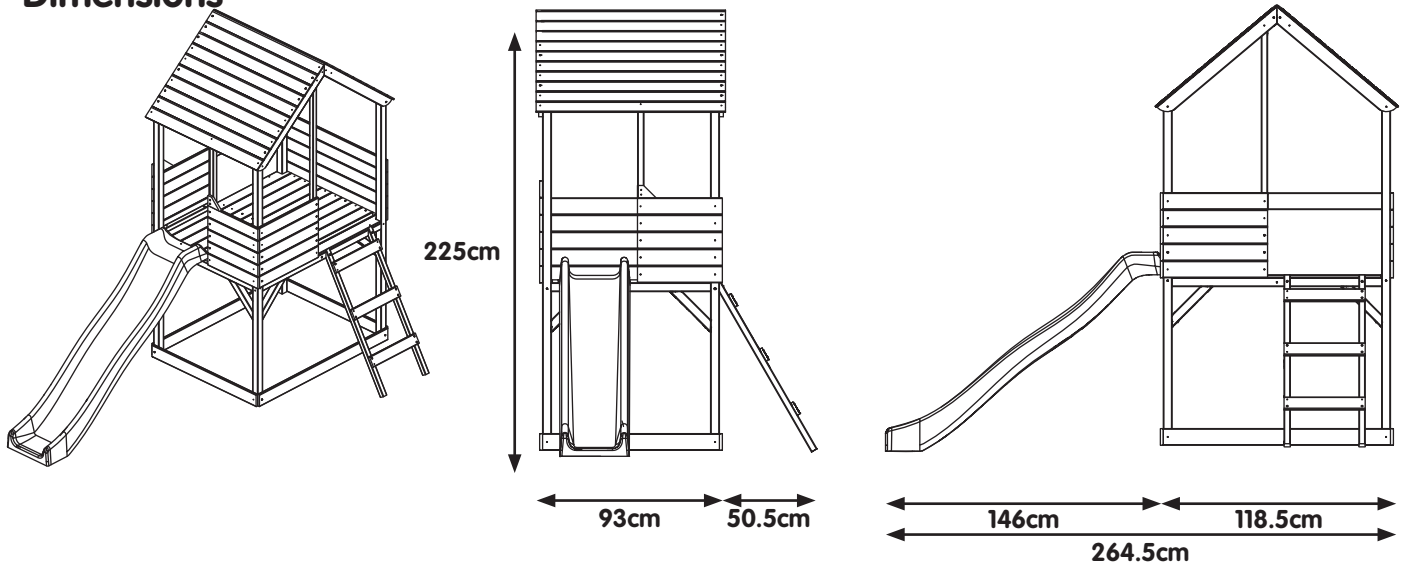

2



2 MW3028 x7 902mm

3



3 MW3027 x2 1159mm

4



4 MW3033 x2 1069mm

5



5 MW3034 x3 814mm

6

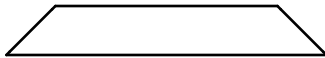

6 MW3001 x8 294mm

7

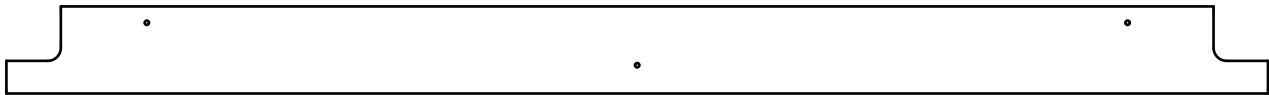

7 MW3020 x2 1159mm

8

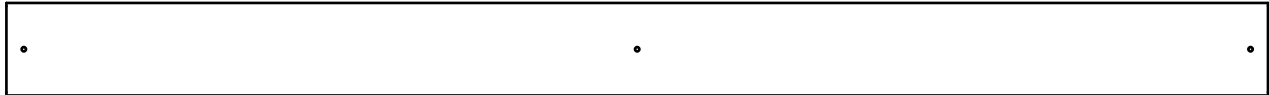

8 MW3021 x8 1159mm

9



9 MW3022 x1 1159mm

10



10 MW3018 x2 455mm

11



11 MW3019 x1 340mm

12

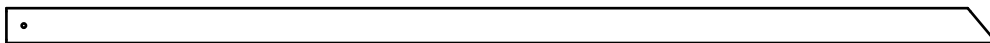

12 MW3036 x1 910mm

14

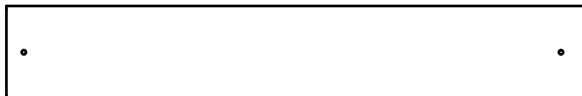

14 MW3029 x9 532mm

15

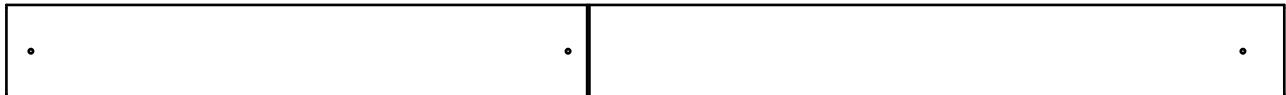

15 MW3031 x1 1171mm

16

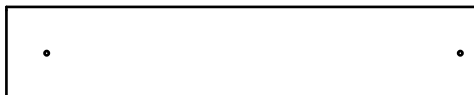

16 MW3030 x5 433mm

17

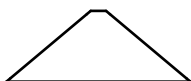

17 MW3023 x2 180mm

18

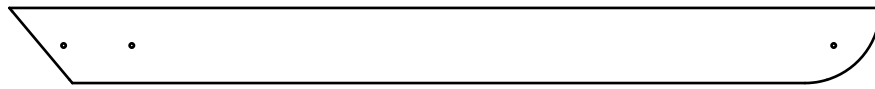

18 MW3024 **x4** 800mm

19

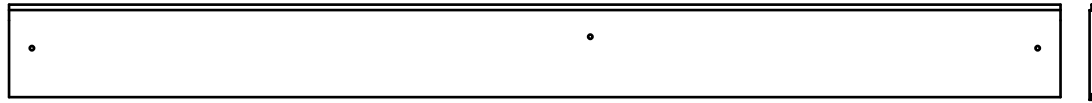

19 MW3338 **x1** 966mm

20

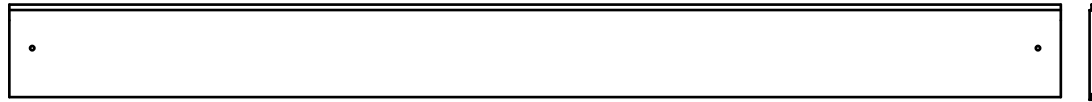

20 MW3025 **x19** 966mm

22

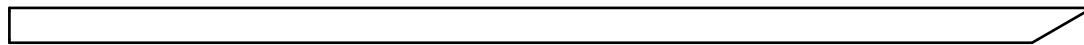

22 MW3002 **x2** 995mm

21



21 MW3003 **x3** 414mm

H

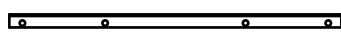

H PR5071 **x4** 305mm

I

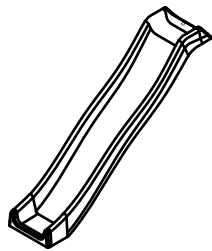

I PM9751 **x1**

J

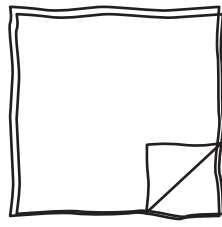

J FB9985 **x1**

23

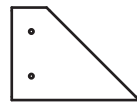

23 MW3340L **x1** 117mm

24

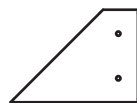

24 MW3340R **x1** 117mm

SP4358



A

A FA8275 5x90mm wood screw **x10**

B

B FA4541 3.5x60mm wood screw **x9**

C

C FA4523 3.5x50mm wood screw **x18**

D

D FA4516 3.5x35mm wood screw **x22**

E

E FA4526 3.5x30mm wood screw **x129**

F

F FA4543 3x16mm wood screw **x8**

G

G FA4546 5x50mm wood screw **x2**

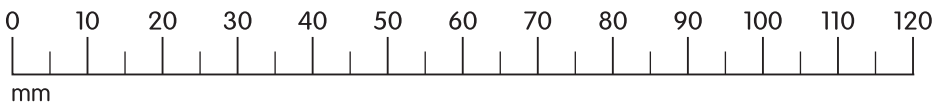

13

13 MW3035 **x2** 1300mm

1L

1L MW3037L **x2** 1755mm

1R

1R MW3037R **x2** 1755mm

1

1R

1R MW3037R x2 1755mm

1L

1L MW3037L x2 1755mm

2

2 MW3028 x2 902mm

5

5 MW3034 x2 814mm



A

A FA8275 5x90mm wood screw x4

E

E FA4526 3.5x30mm wood screw x4

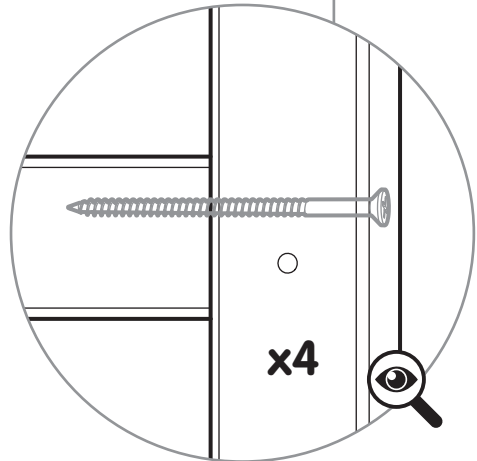
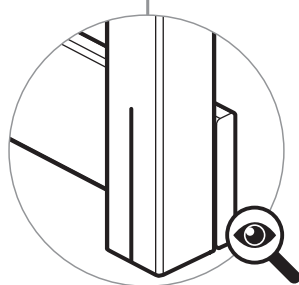
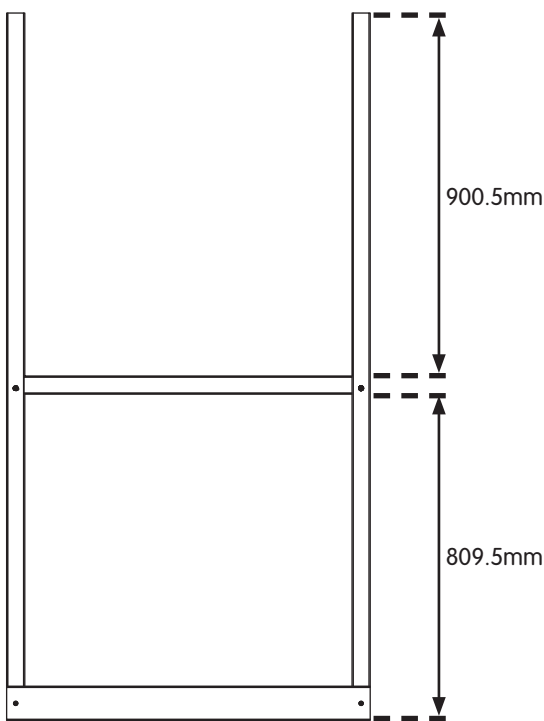
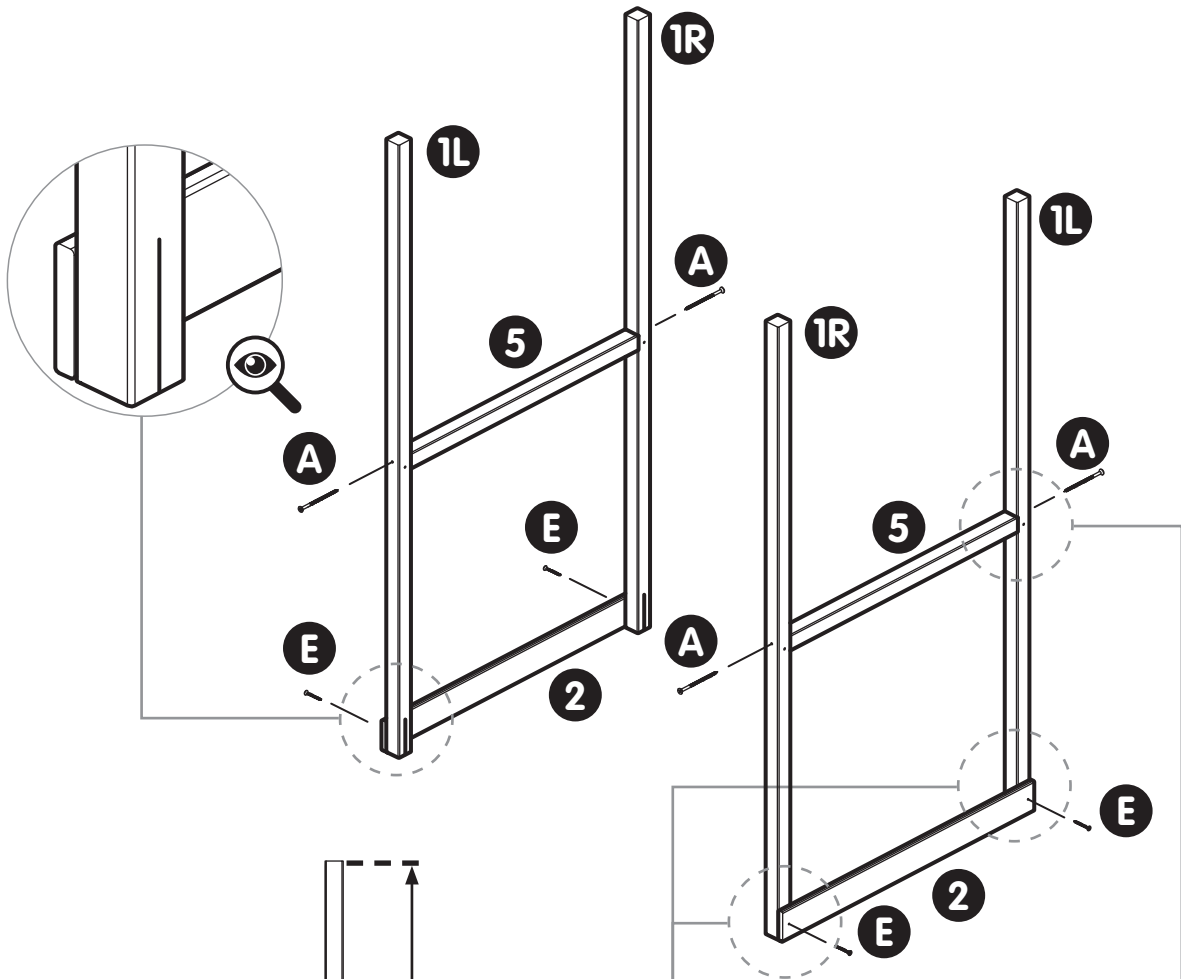

x4

2



A A FA8275 5x90mm
wood screw **x4**

4

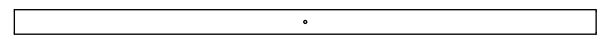

4 MW3033 **x2** 1069mm

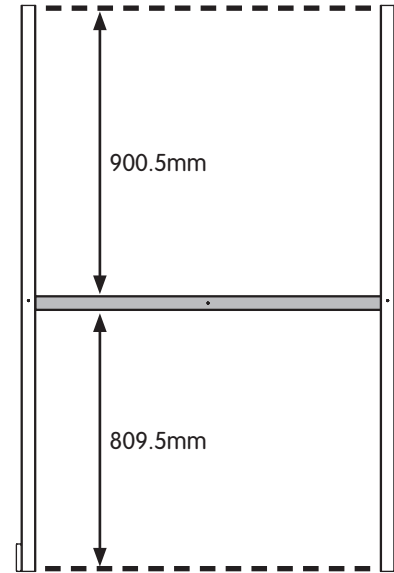
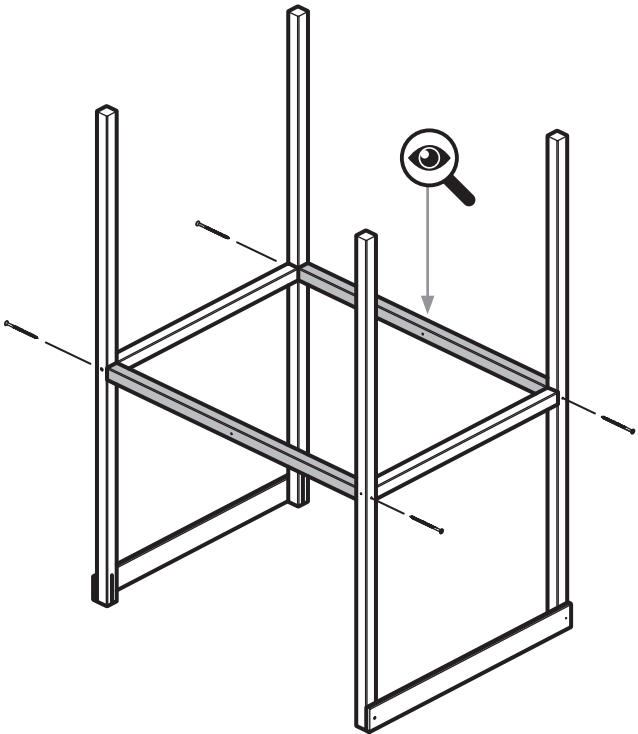

3



E E FA4526 3.5x30mm
wood screw **x4**

3



3 MW3027 **x2** 1159mm

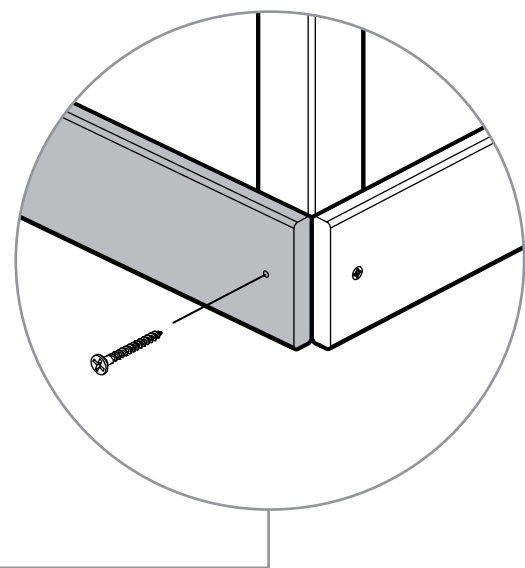
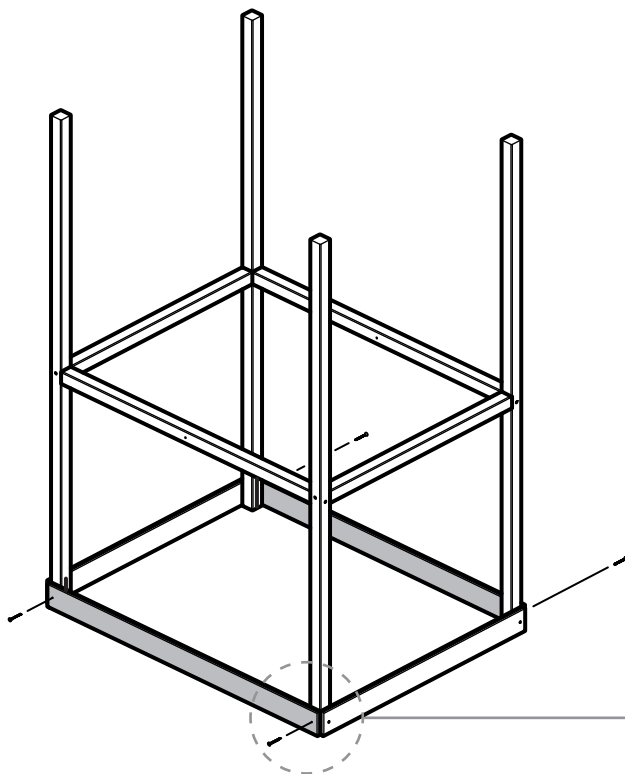

4



A FA8275 5x90mm
wood screw **x2**

5

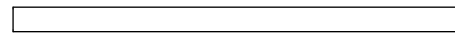

5 MW3034 **x1** 814mm

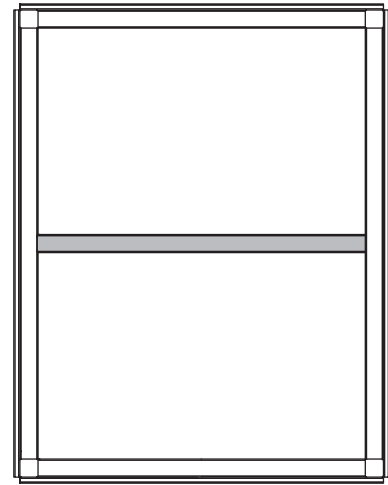
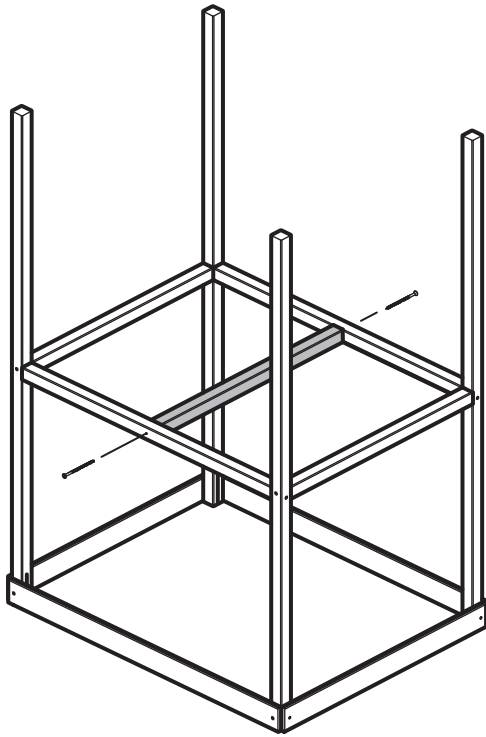

5



C FA4523 3.5x50mm
wood screw **x16**

6

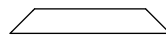

6 MW3001 **x8** 294mm

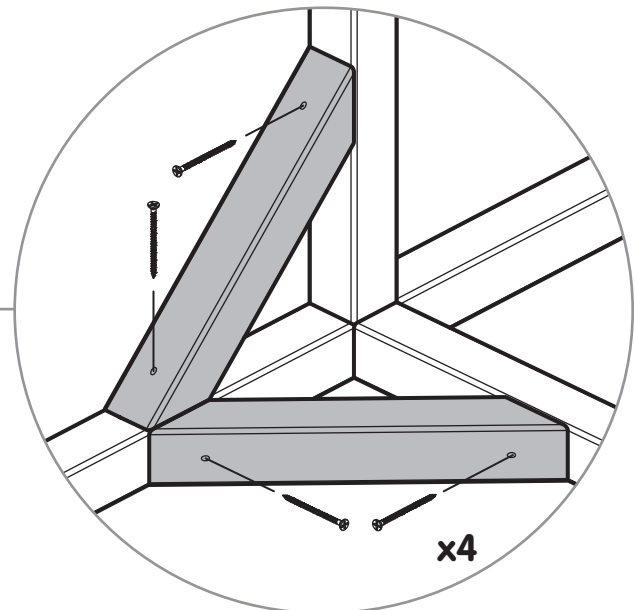
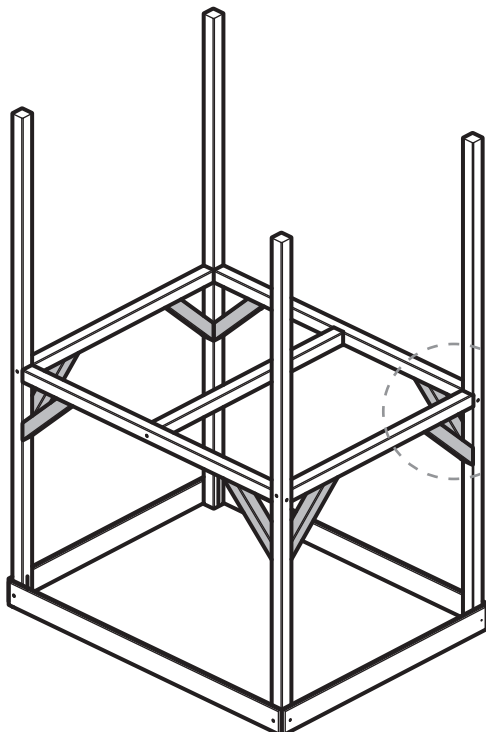

6

7

7 MW3020 x2 1159mm

8

8 MW3021 x8 1159mm

9

9 MW3022 x1 1159mm



E

E FA4526 3.5x30mm wood screw x33

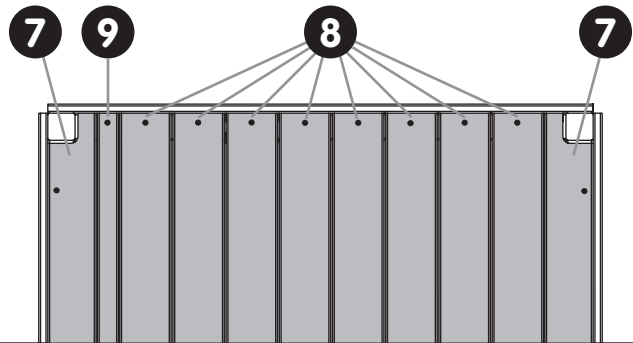
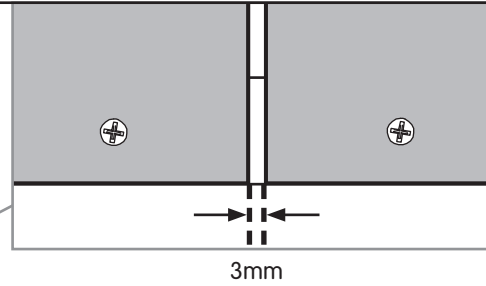
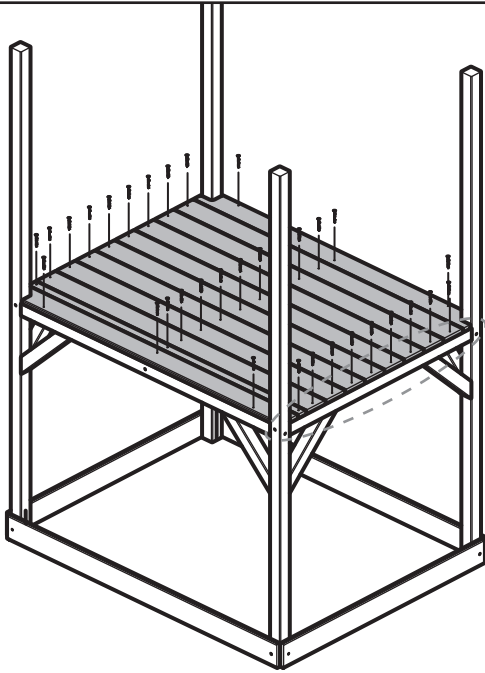

7

10

10 MW3018 x2 455mm

11

11 MW3019 x1 340mm



B

B FA4541 3.5x60mm wood screw x6

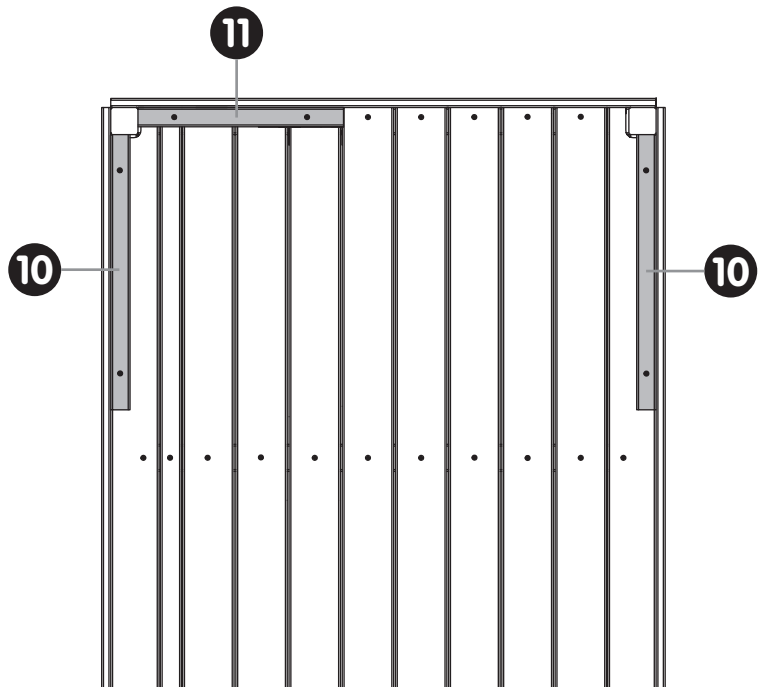
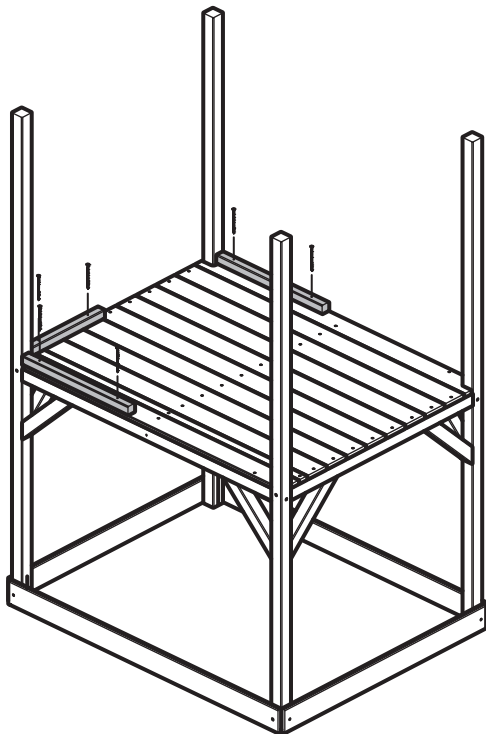

17

8

12

12 MW3036 x1 910mm

13

13 MW3035 x2 1300mm



B FA4541 3.5x60mm wood screw x3

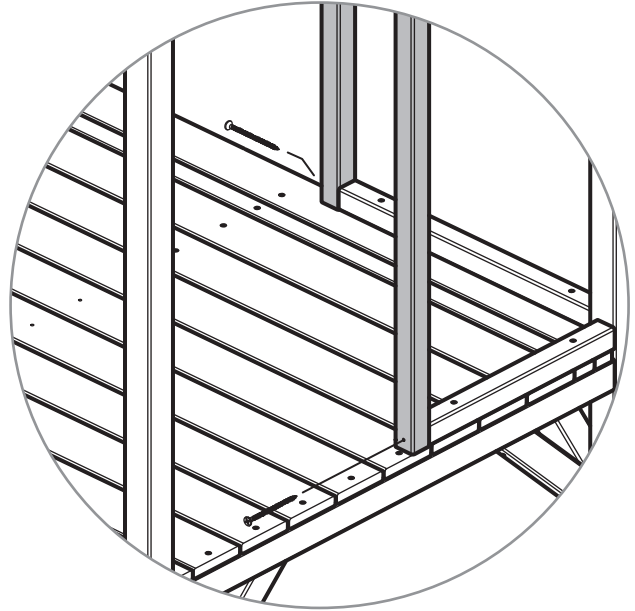
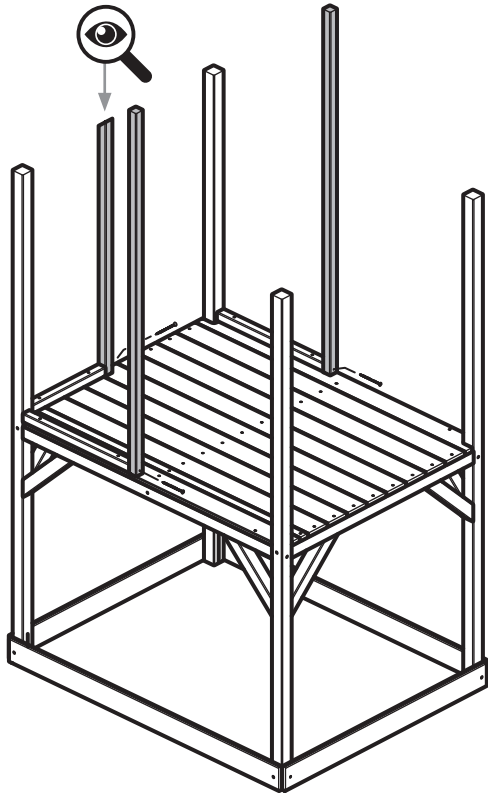

9

21

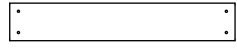

21 MW3003 x3 414mm



C FA4523 3.5x50mm wood screw x2

22

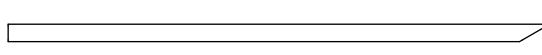

22 MW3002 x2 995mm



D FA4516 3.5x35mm wood screw x12

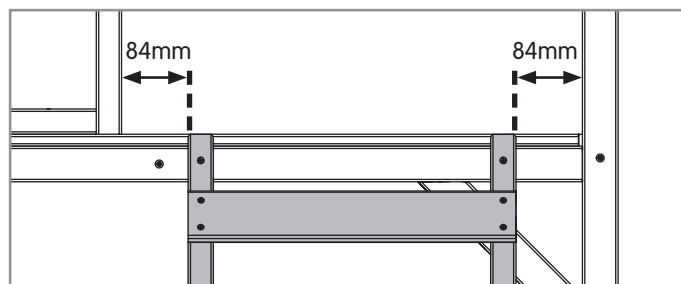
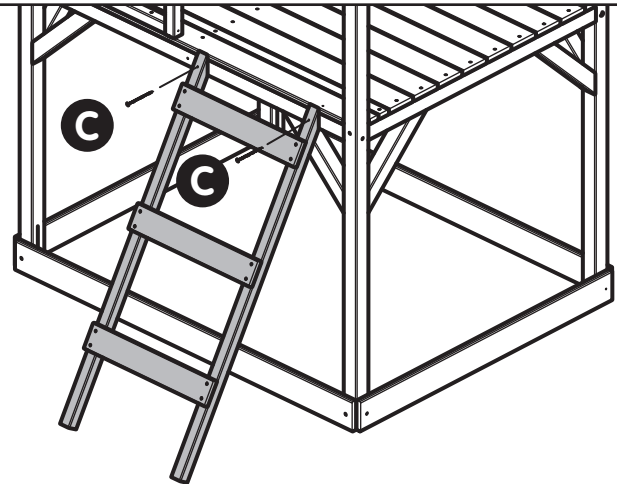
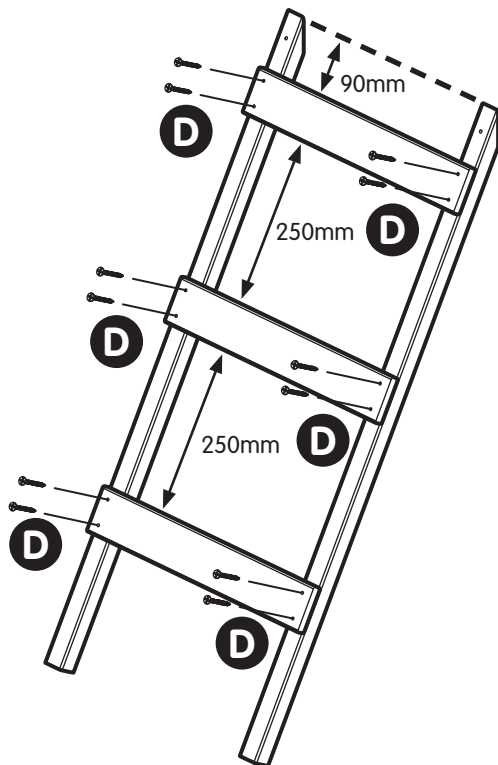

18

10**14**

14 MW3029 x5 532mm

2

2 MW3028 x5 902mm

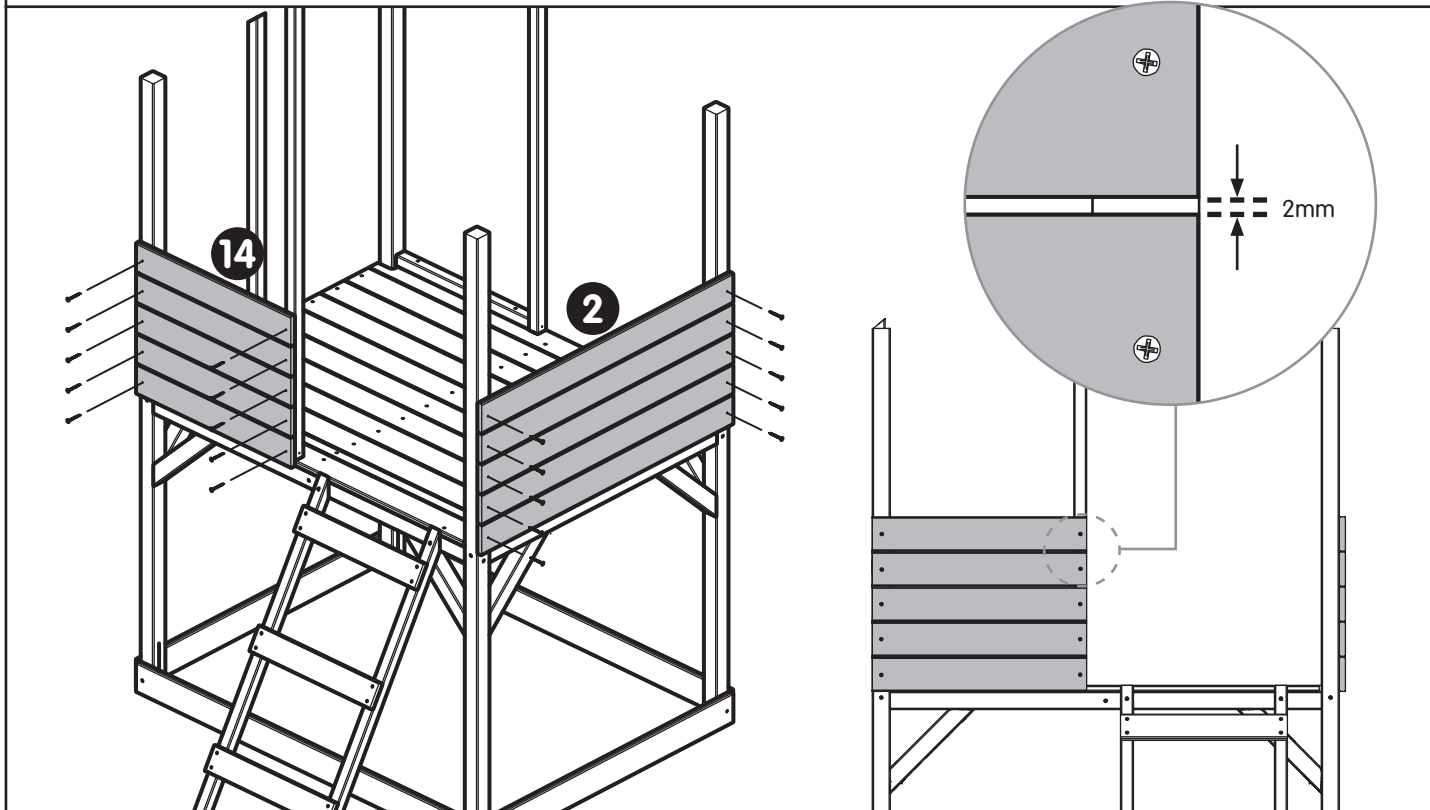
**E**E FA4526 3.5x30mm
wood screw x20**11****14**

14 MW3029 x4 532mm

16

16 MW3030 x5 433mm

15

15 MW3031 x1 1171mm

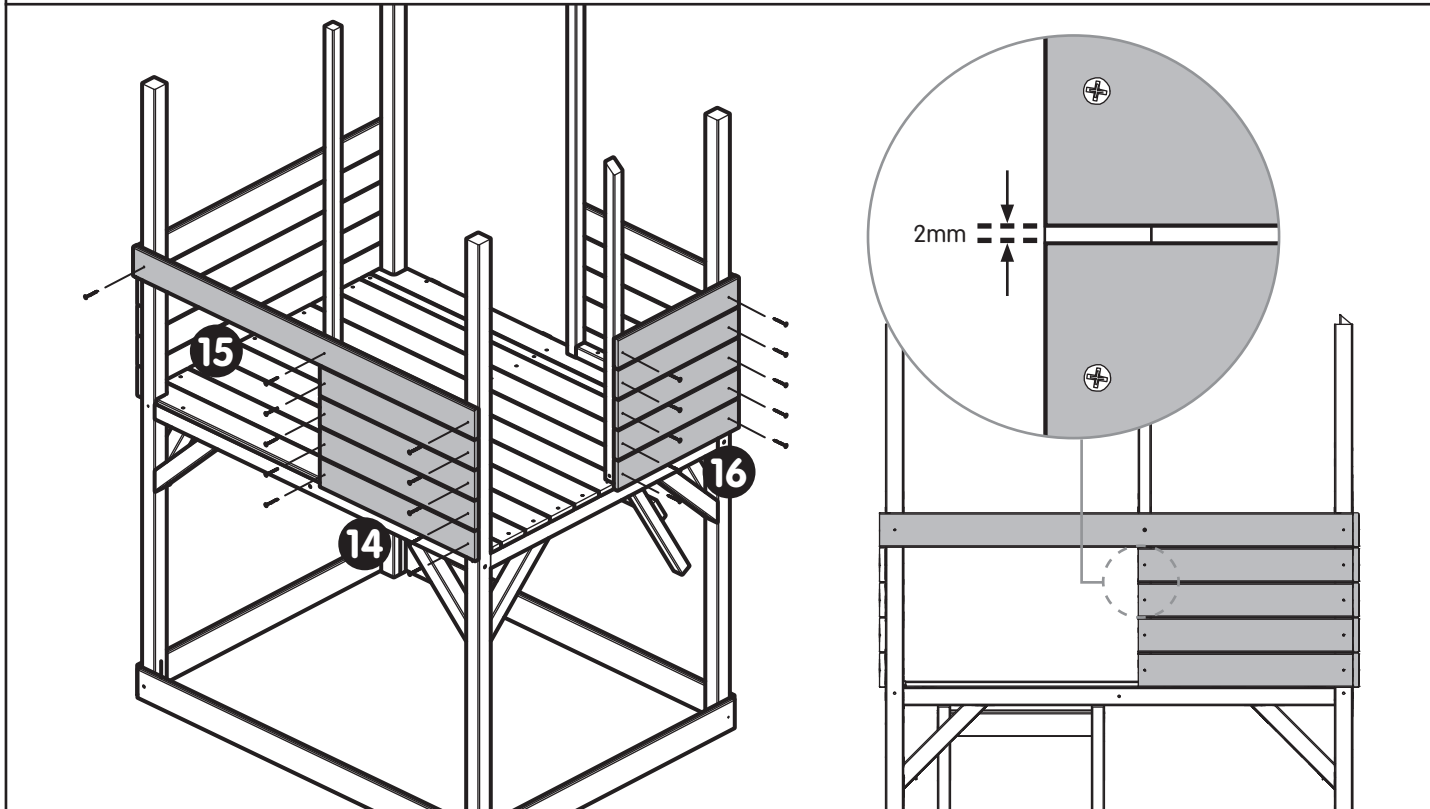
**E**E FA4526 3.5x30mm
wood screw x21**19**

12

17

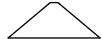

17 MW3023 x2 180mm

18



18 MW3024 x4 800mm



D FA4516 3.5x35mm wood screw x10

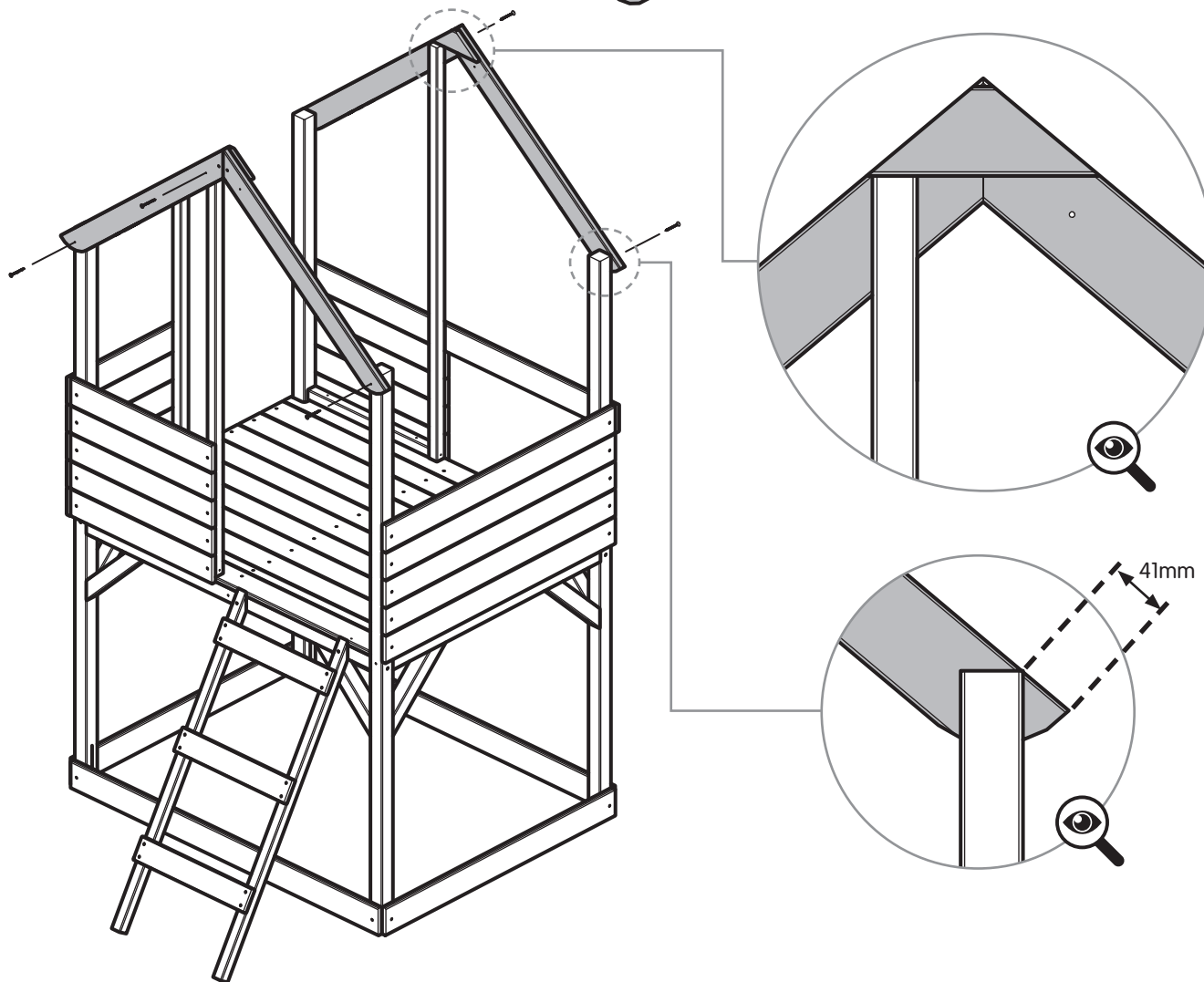
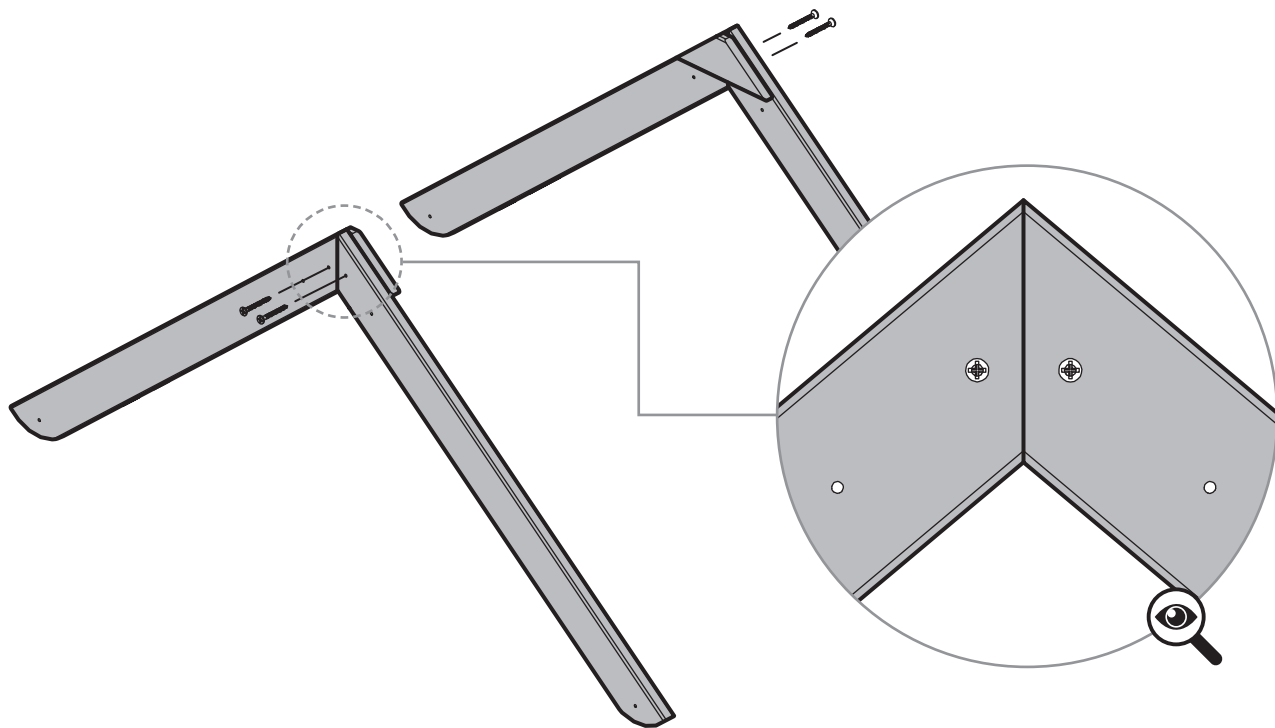

13

19

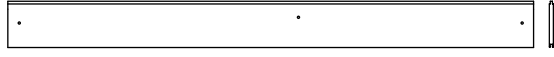

19 MW3338 x1 966mm

20

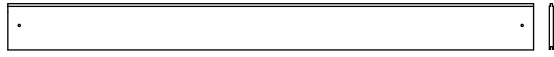

20 MW3025 x19 966mm



E FA4526 3.5x30mm wood screw x41

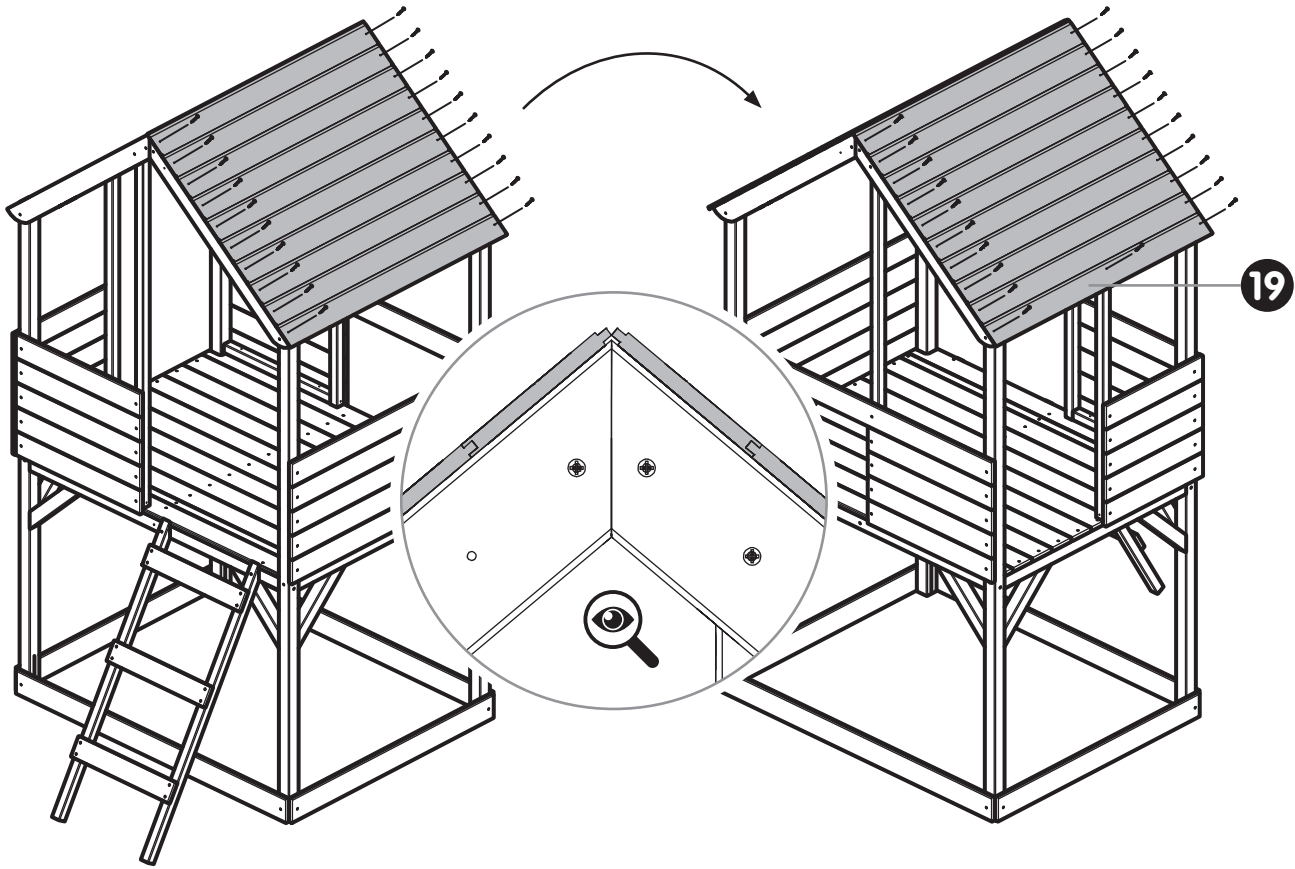

14



F FA4543 3x16mm wood screw x8

H

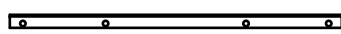

H PR5071 x4 305mm

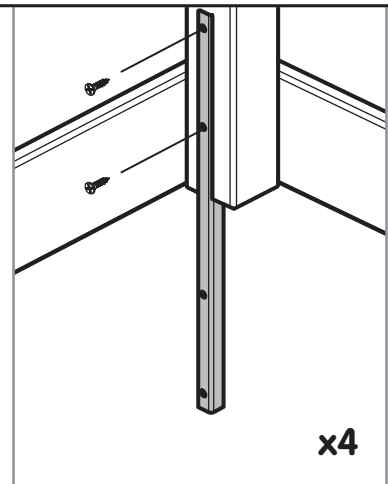
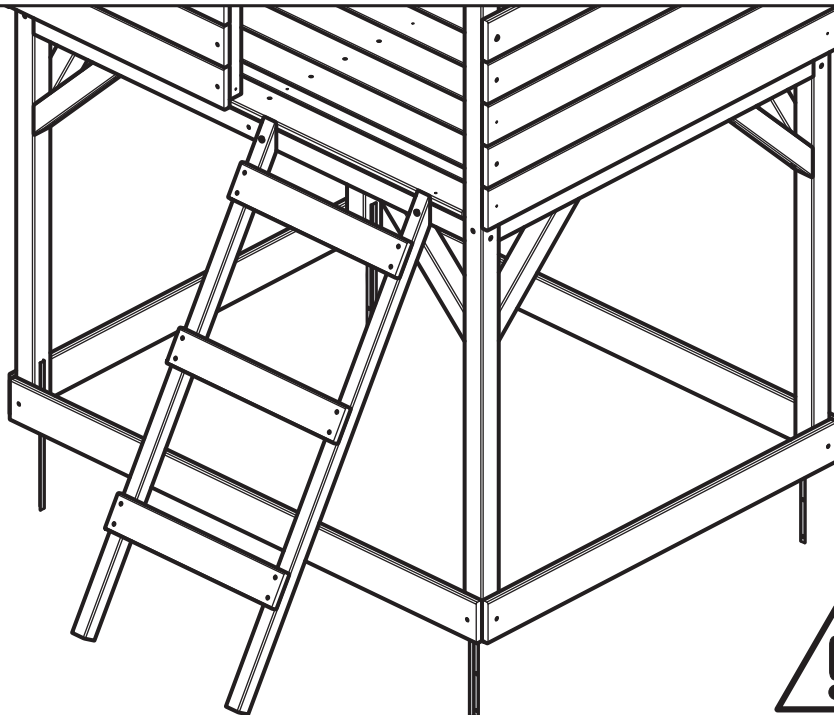

*MOVE TO FINAL LOCATION BEFORE ADDING GROUND PEGS

*2 OR MORE PEOPLE ARE REQUIRED TO MOVE PLAYHOUSE



x2

15

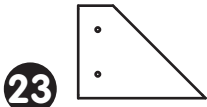

23

23 MW3340L x1 117mm

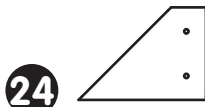

24

24 MW3340R x1 117mm



E

E FA4526 3.5x30mm
wood screw x6

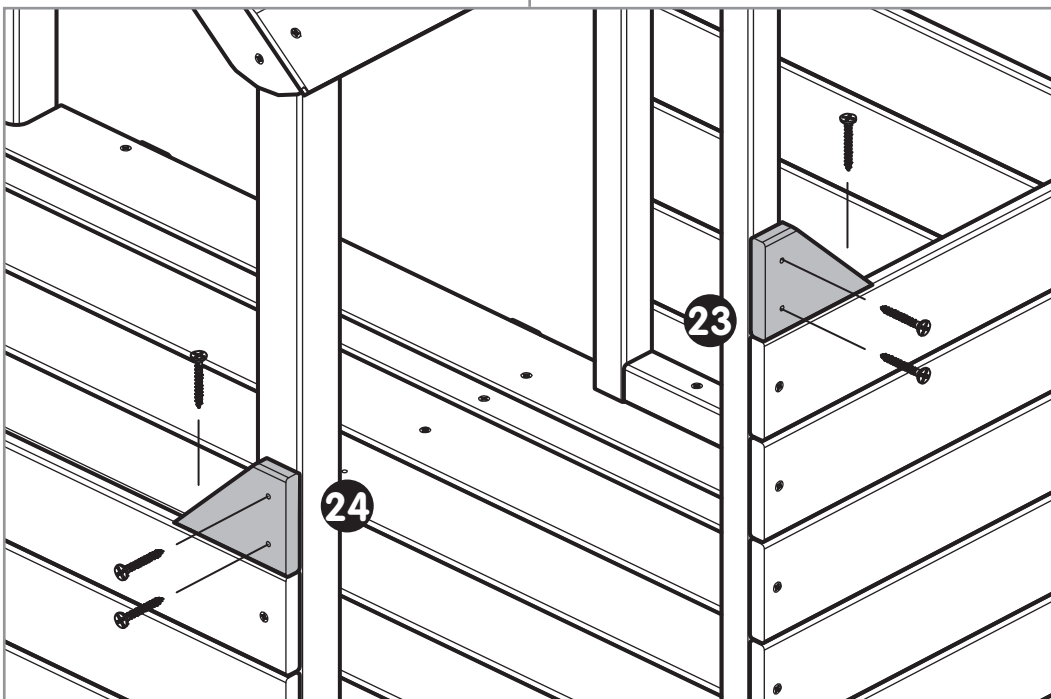
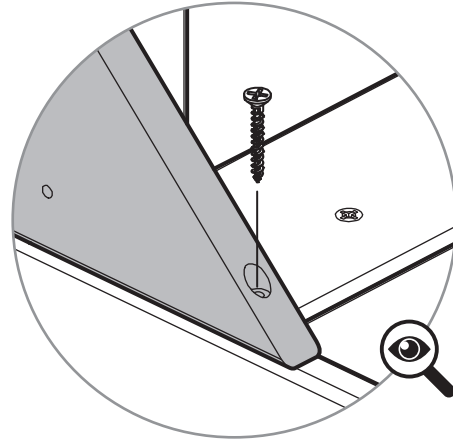
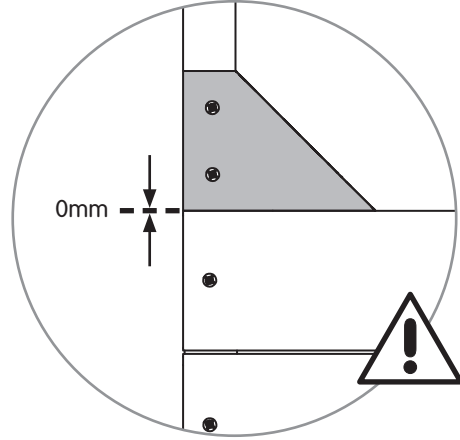
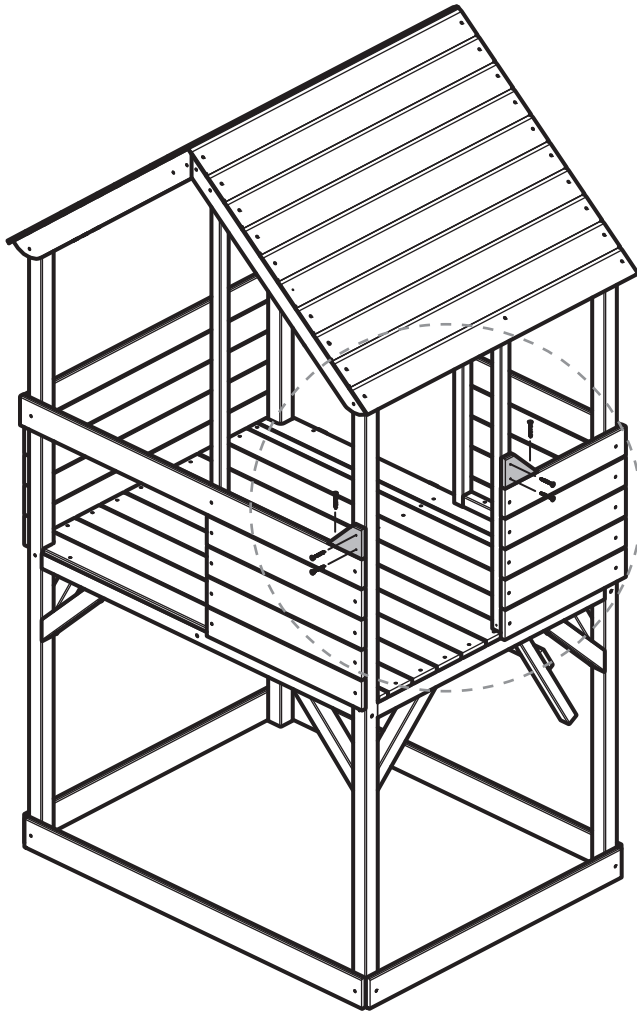

22

16



I PM9751 x1



G FA4546 5x50mm wood screw x2

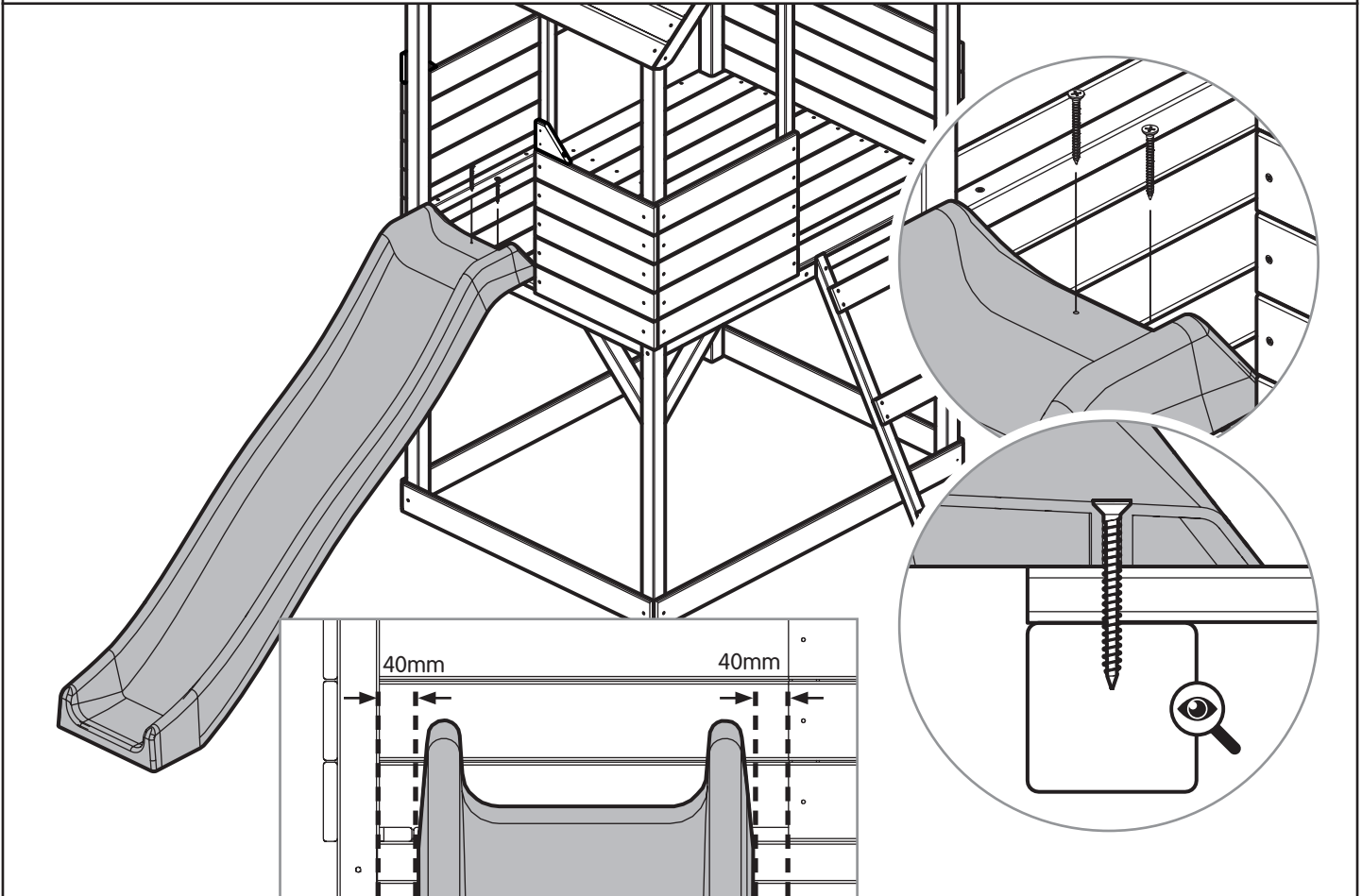

17



J FB9985 x1

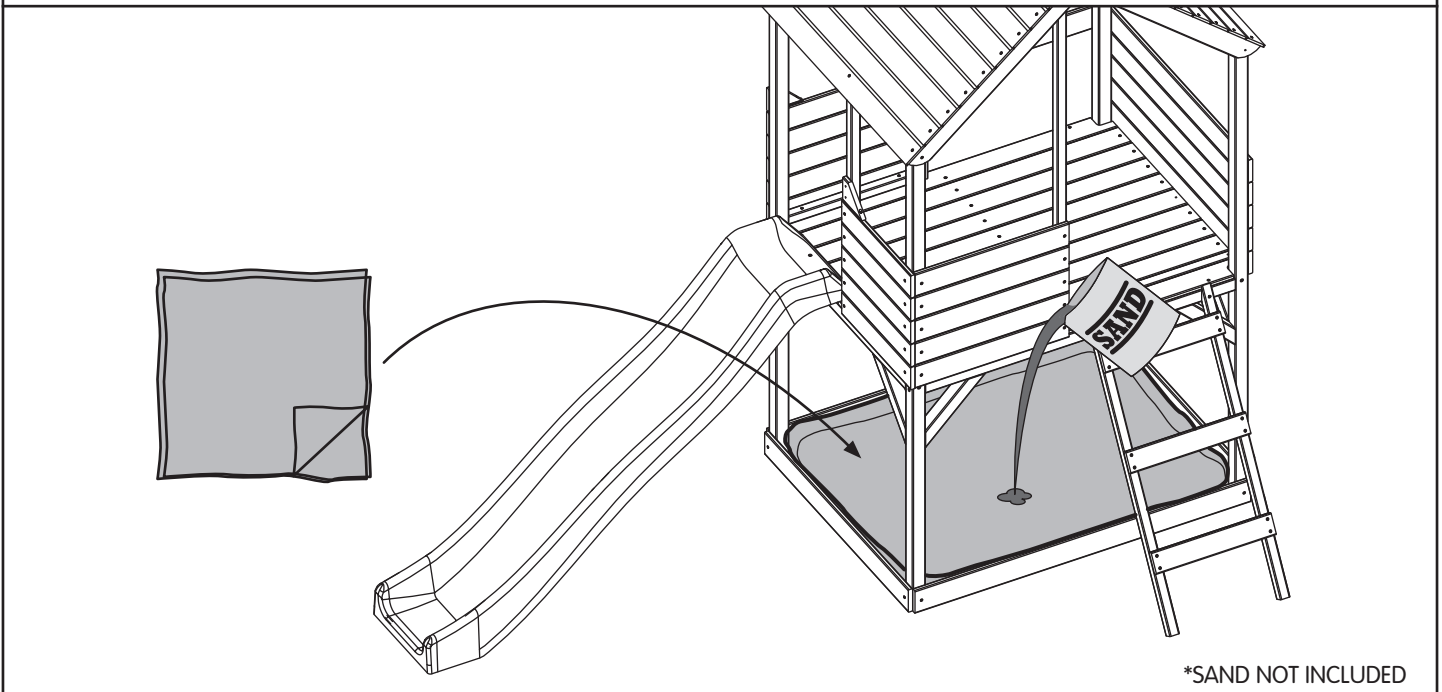



Thank you

Thank you for purchasing this product.

Please register your new product on line at tptoys.com

www.tptoys.com/customer/productregistration

Find out about the guarantee for this product,

visit **www.tptoys.com/customer/pages/guaranteeinformation**

For customer services and help with your product,

visit **www.tptoys.com/customer/help**

or email **help@tptoys.com**

MADE IN CHINA

FOR AU / NZ: IMPORTED FOR KMART

STORES IN AUSTRALIA AND NEW ZEALAND

42949442

Your TP Guarantee Number/Product Batch No is