

说明书, 100克双铜纸,
尺寸: 21*40CM

LED CAMPING KIT INSTRUCTIONS

Important: Please read these instructions carefully prior to installation.

Warning: Use caution when connecting cables to car battery as this may cause injury when not carried out correctly
Do not look directly at LED Light as it can cause eye Damage.
Read all instructions before use. If you are unsure on any items, please contact the place of purchase.

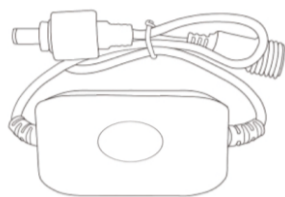

1x Led Touch Dimmer

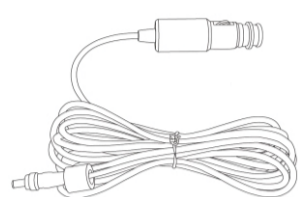

1x 3m Lead to Cigarette Adaptor

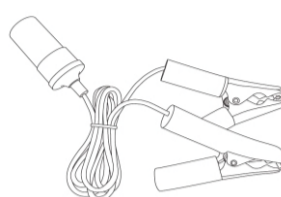

1x Batteries Clamp Adaptor

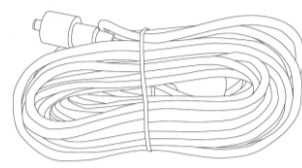

3x Extension Lead

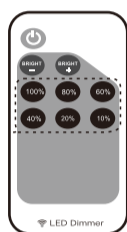

1x Led Dimmer



8 x Plastic Lock Strap



8 x Velcro Tie



4 x Led Light Bar

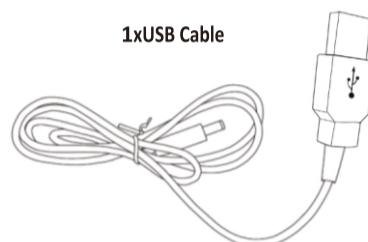

1x USB Cable

1. Basic Kit Set Up.

Requires: LED Light Bar + LED Touch Dimmer + Power Supply + Batteries Clamp (Optional)

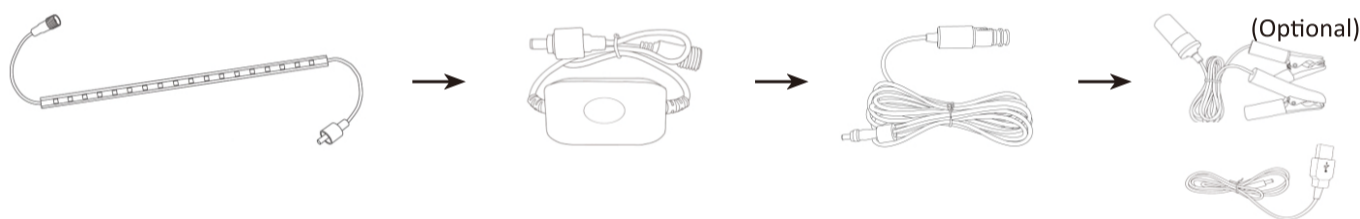

Note: Only 6x50cm LED light bars can be used together. More than 6 may cause overheating.

2. Connection as shown.

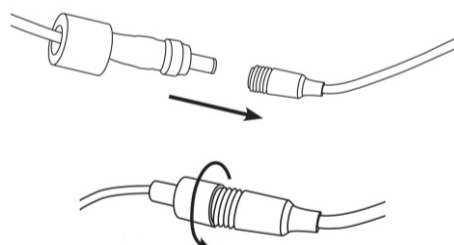

3. LED Dimmer

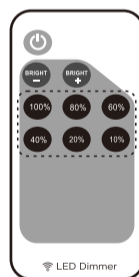

Once all items are connected, switch On/off LedDimmer/12V Power.

Position the LED Light Bar by using magnets.

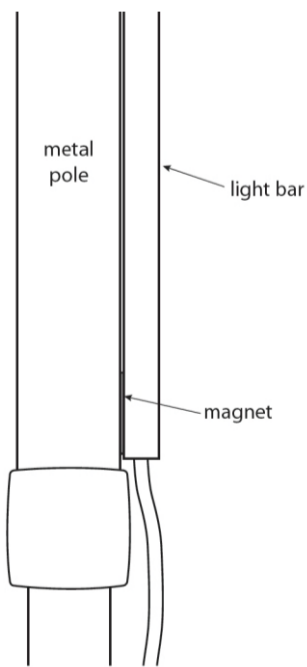

4. Install the LED Light Bar to the Pole

Use Velcro Straps to connect the LED Light Bar to a Pole. Ensure leads are tucked away neatly to avoid any trip hazards.

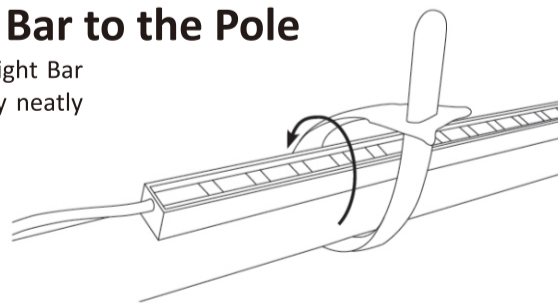

Or →

When using Alligator Clamp, the 5m Cigarette Lead must be used to attached into the female socket.

When red collar is removed from cigarette socket it can be used to fit into merit sockets.

5. Batteries connection as shown

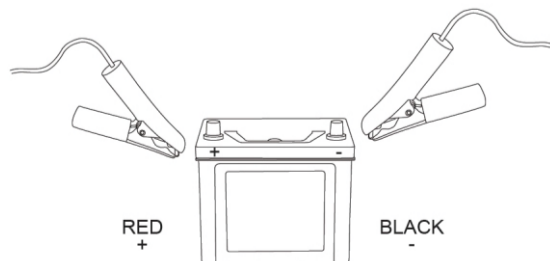
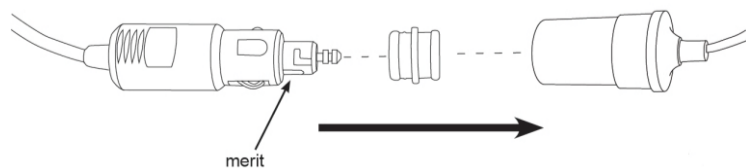

RF Wireless Remote

LED Dimmer

Instructions

- For LED Strip/Module
- 64-level Dimmer
- 8 Shortcut Brightness
- 5-24V Wide Voltage
- High Out Current
- Card Type RF Remote
- Ultra Slim Design
- Smooth Dimmer Effect
- Easy Remote Pairing
- Power off Memorize

1. Turn On/Standby

Press this key to turn on or switch to standby mode. At power on, unit will automatically turn on and restore to previous status.

2/4. Brightness Adjust

Adjust LED brightness Press BRIGHT+ to increase brightness and press BRIGHT- to decrease brightness.

3. Brightness Shortcuts

Directly switch to 100%, 80%, 60%, 40%, 20% or 10% of full brightness.

Functions

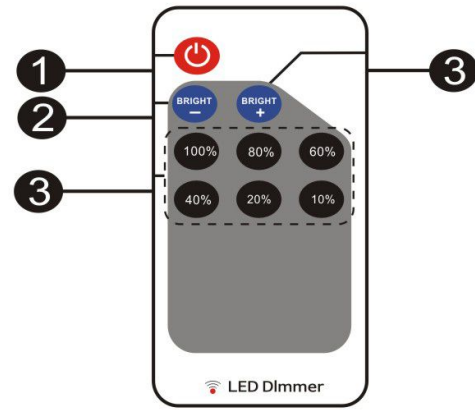

Installing

1. Power Supply

This unit accepts DC 5V to 24V power supply. The red cable (or inner pole of DC jack) should be connected to positive and black cable (or sleeve pole of DC jack) to negative. Please make sure the power supply voltage is same as the LED load.

2. LED Output

The red cable (or inner pole of DC plug) should be connected to LED positive and black cable (or sleeve pole of DC plug) to negative.

The peak output current is 12 amperes and maximum constant current is 6 amperes, please reduce load if main unit is overheating.

CAUTION! Do not short circuit or overload the LED outputs, this may lead to permanent damage!



Operation

1. Using Remote Controller

Remove insulation tape before using. To ensure a clear signal do not surround the main unit in metal.

3. Remote Pairing Mode

In some specific cases, the main unit may need to be paired to any remote controllers. Please do following steps for remote pairing mode:

1). Plug off the power of main unit and plug in after 5 seconds.

2). Press 'ON/OFF' and 'BRIGHT+' key together in 5 seconds after power on.

After this operation, the main unit will recognize any remote controller. To pair the main unit back to specific remote, please repeat the 'Pairing New Remote' operation.

2. Pairing New Remote

the remote works as a default with the main unit. Other remote controllers can be paired to the main unit.

to pair a new remote, turn the power off on the main unit, after 5 seconds turn back on then press 100% and 60% keys. the main unit should now recognize the new remote.

WARNING

SWALLOWING MAY LEAD TO SERIOUS INJURY OR DEATH IN AS LITTLE AS 2 HOURS DUE TO CHEMICAL BURNS AND POTENTIAL PERFORATION OF THE OESOPHAGUS. DISPOSE OF USED BATTERIES IMMEDIATELY AND SAFELY. FLAT BATTERIES CAN STILL BE DANGEROUS. EXAMINE DEVICES AND MAKE SURE THE BATTERY COMPARTMENT IS CORRECTLY SECURED, E.G. THAT THE SCREW OR OTHER MECHANICAL FASTENER IS TIGHTENED. DO NOT USE IF COMPARTMENT IS NOT SECURE

IF YOU SUSPECT YOUR CHILD HAS SWALLOWED OR INSERTED A BUTTON BATTERY, CALL THE 24HOUR POISONS INFORMATION CENTRE IN AUS ON 131126 OR IN NZ 0800 764 766 OR CONTACT YOUR COUNTRY'S EMERGENCY DEPT.

Specification

Lighting brightness level	64 levels
Brightness Shortcut	6 shortcuts
Smooth dimmer effect	Yes
Working voltage	DC 5 ~ 24V
Output current	peak 12A, constant 6A
Remote control mode	RF Wireless
Remote frequency	433.92MHz
Remote distance	10m at open area