

anko

2-In-1 Reversible Stroller Instruction Manual

0-36
months

15
kg

MAXIMUM
WEIGHT

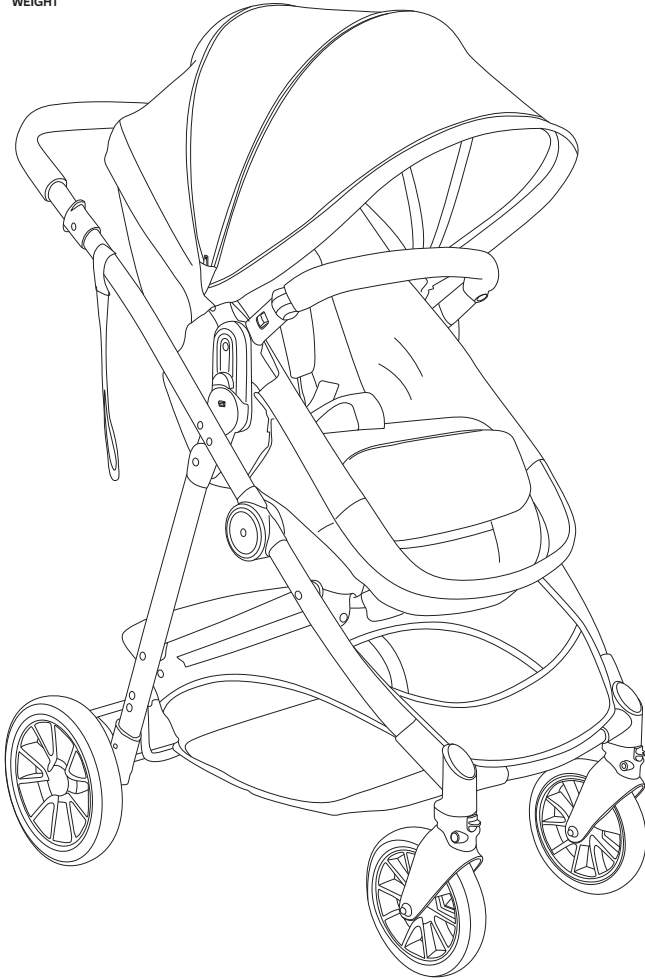

THE ILLUSTRATIONS SHOWN IN THIS MANUAL ARE FOR REFERENCE ONLY. THE MANUFACTURER RESERVES THE RIGHT TO CHANGE ANY SPECIFICATION OR FEATURE WITHOUT FURTHER NOTICE. IMPORTANT! PLEASE READ CAREFULLY BEFORE USE AND KEEP FOR FUTURE REFERENCE.



CAUTION: TO AVOID INJURY OR DEATH

Read these instructions carefully before use and keep for future reference. The child may be hurt if you do not follow these instructions.

 **WARNING:** FOLLOW THE MANUFACTURER'S INSTRUCTIONS.

 **WARNING:** ALWAYS APPLY THE BRAKES WHENEVER THE PRAM/STROLLER IS STATIONARY.

 **WARNING:** DO NOT LEAVE THE CHILD UNATTENDED.

 **WARNING:** SECURE THE CHILD IN THE HARNESS AT ALL TIMES.

 **WARNING:** DO NOT CARRY EXTRA CHILDREN OR BAGS ON THIS PRAM/STROLLER.

 **WARNING:** ENSURE CHILDREN ARE CLEAR OF ANY MOVING PARTS IF YOU ADJUST THE PRAM/STROLLER. OTHERWISE THEY MAY BE INJURED.

 **WARNING:** USE THE HARNESS AT ALL TIMES.

 **WARNING:** USE THE TETHER STRAP TO STOP THE PRAM/STROLLER ROLLING AWAY.

 **WARNING:** NEVER LEAVE PRAM/STROLLER NEAR AN OPEN FIRE OR EXPOSED FLAME.

 **WARNING:** IT IS UNSAFE TO USE ACCESSORIES OTHER THAN THOSE APPROVED BY THE MANUFACTURER.

- Always fit and use the tether strap when the stroller is in use.
- When using the stroller, always ensure your hand is positioned in and around the tether strap. The strap is a compulsory safety feature which must be used at all times. It is for the safety and benefit of your child.
- The correct use and maintenance of this stroller is essential.
- Ensure that all clamps and buckles are securely fixed and in place before use.
- When in the stroller, your child must always wear the safety harness, correctly fitted and adjusted, at all times.

- Never leave the harness buckles when not fitted to a child in the stroller because the harness can form loops which may pose a strangulation hazard.
- The maximum weight of the child for which this stroller is intended is 15kg.
- The stroller will become unstable if the manufacturer's recommended load is exceeded.
- Use the stroller on flat or gently sloping surfaces. It may be unstable on higher sloping and uneven surfaces - be aware of the possibility of the stroller tipping over.
- Care should be taken if the stroller is used on stairs or escalators.
- Care must be taken when folding and unfolding the product to prevent finger entrapment.
- The stroller is not suitable for running or skating.
- Any goods carried in the basket are not to exceed 2 kg.
- Do not leave your child exposed to the sun. The canopy or hood on this product will not give your child total protection from the harmful rays of the sun.
- Take care when unpacking and during assembly.
- Dispose of all packing materials carefully after assembly.
- Never substitute parts.
- It is unsafe to use accessories other than those approved by the vehicle manufacturer.
- The pram/stroller not be used near an open fire or exposed flame.
- The brakes must always be applied when the pram/stroller is not moving.

PARTS

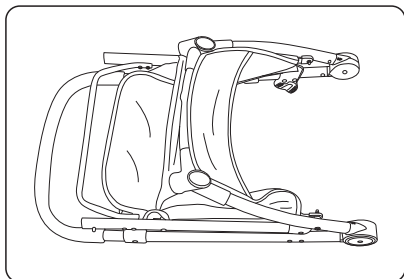

FRAME

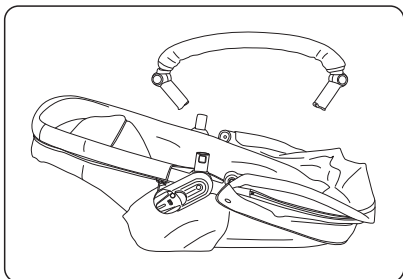

SEAT AND BUMPER BAR

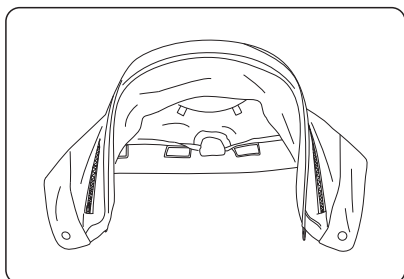

CANOPY

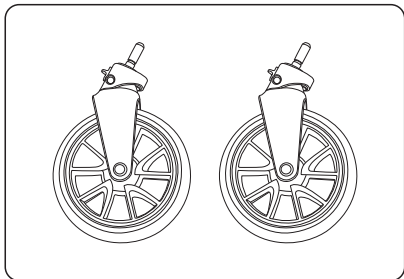

FRONT WHEELS

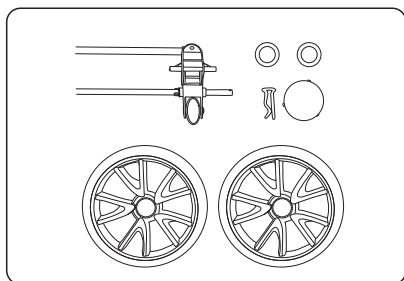

REAR WHEELS

Assembly Instructions

SET UP THE FRAME

Remove the stroller frame from the box. Pull the handle bar in an upwards and forwards motion. It is fully extended when a click is heard.

Note: It is necessary to check all parts before assembly to ensure there are no defects, loose screws, sharp edges, etc. Do not use if any parts are broken or damaged.

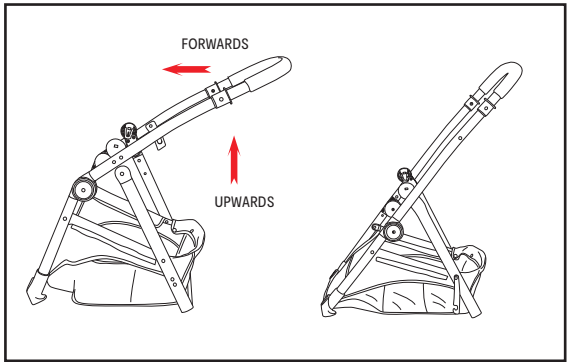

FRONT WHEEL INSTRUCTIONS

Refer to illustrations: ① ②
Push each front wheel pin into the front wheel socket until a click is heard.

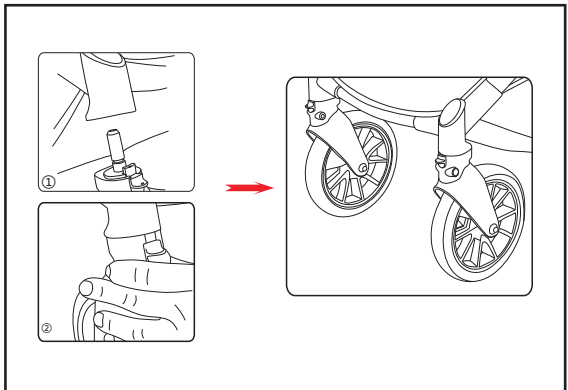

REAR WHEEL INSTRUCTIONS

As shown in the illustrations:
Place one metal washer onto the end of the rear axle ②, place one wheel followed by another washer ③, insert the straight side of the cotter pin through the hole in the axle to secure ④, fit the cover ⑤;
Repeat these steps for the other wheel.

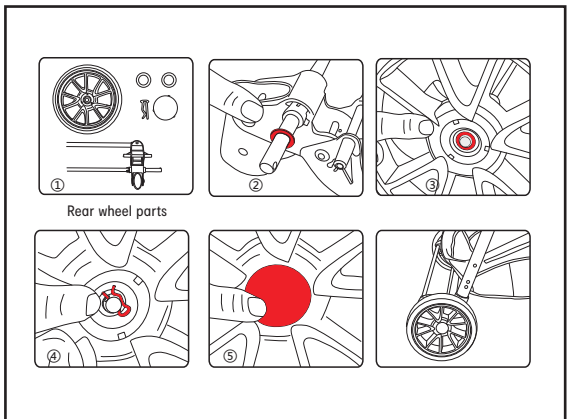

ATTACHING THE SEAT

To attach the seat unit to the frame, line up the seat connectors at either side of the seat unit with the frame housing and press down until you hear it click into place.

To remove the seat unit press the release buttons as shown in the image and lift seat.

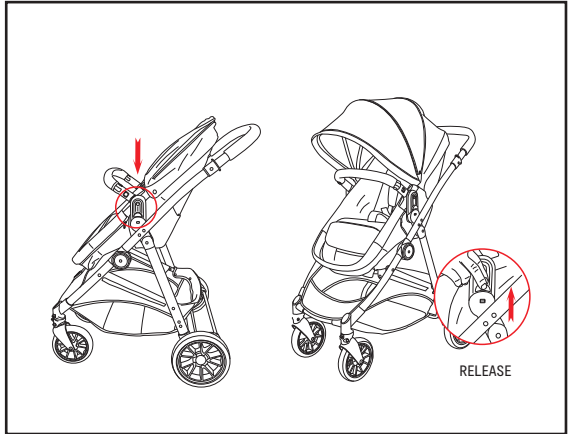

BUMPER BAR INSTRUCTIONS

Insert the bumper bar into the slots on either side of the seat unit until a click is heard. Give the bumper bar a tug to ensure it is securely in place.

To remove the bumper bar, press the release buttons on both sides and lift off.

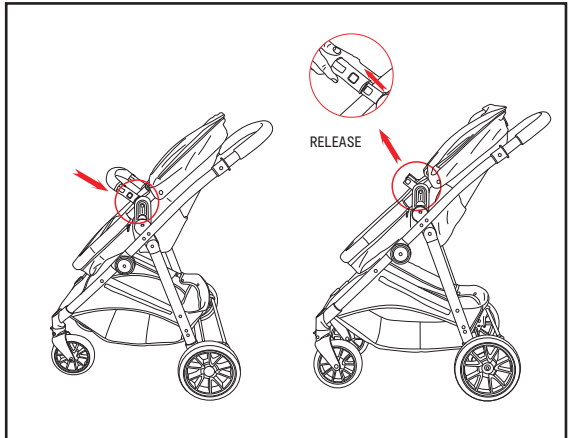

CANOPY INSTRUCTIONS

Insert the canopy into the anchors on the seat in the direction indicated by the arrow until it clicks into place. Fasten the grip fasteners to the seat unit.

Open the zip to reveal the extension panel for added sun protection.

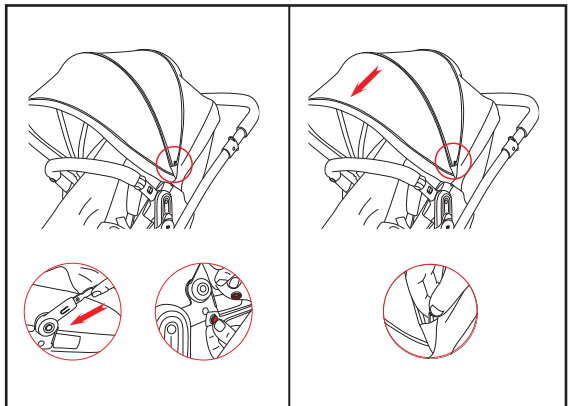

SEAT DIRECTION ADJUSTMENT

The seat unit is reversible and can be used forward facing or rear facing. Press the release buttons on each side of the seat unit to remove and rotate the direction. Line up the seat connectors with the frame housing and press down until a click is heard.

Note: when using in bassinet mode for newborns, the seat unit should only be used rear facing.

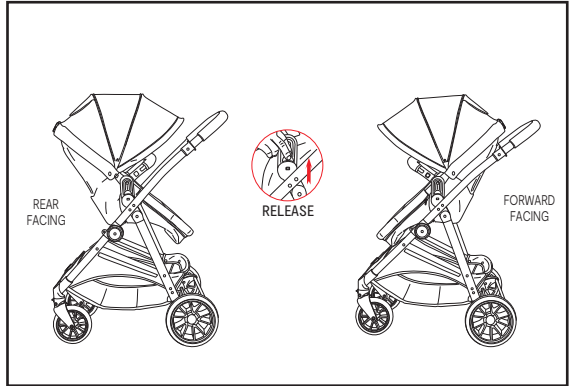

BACKREST ADJUSTMENT

This stroller has 3 recline positions. The seat can be adjusted into upright, half-reclined and reclined positions. Pull the button on the frame, lift it up and release button. The different recline positions are in position once a "CLICK" is heard.

Note: To adjust seat unit position lift the release button and hold while changing positions then release.

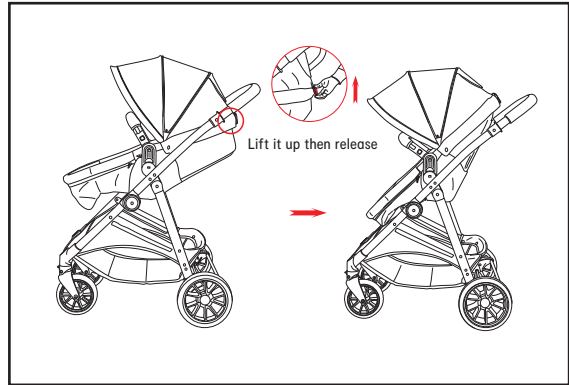

FRONT WHEEL LOCK

The front wheels are equipped with a swivel locking device. Push the button on each wheel down to fix the locks and push upward to disengage the locks.

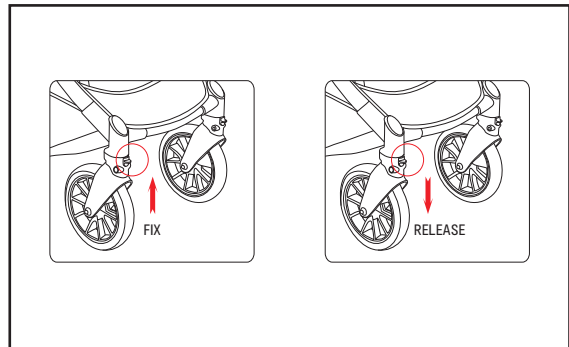

BRAKE OPERATION

To engage brakes, apply downward pressure to the brake lever located on the rear axle. You may need to roll the stroller back and forth to engage the brakes.

Check that the stroller will not move once the brakes are properly applied.

To release, gently lift up on the brake lever.

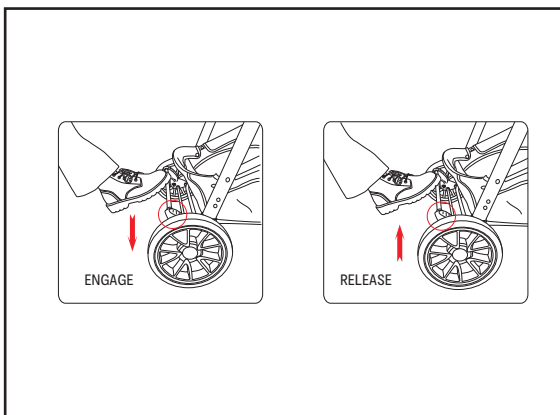

5-POINT SAFETY HARNESS

Insert the shoulder strap buckle ① into the buckle housing of centre hub.

Repeat on the other side ②.

Insert the completed waist buckle ③+④ into the buckle housing.

Ensure all the buckles are in place and securely engaged.

To release buckles, press centre button on buckle housing.

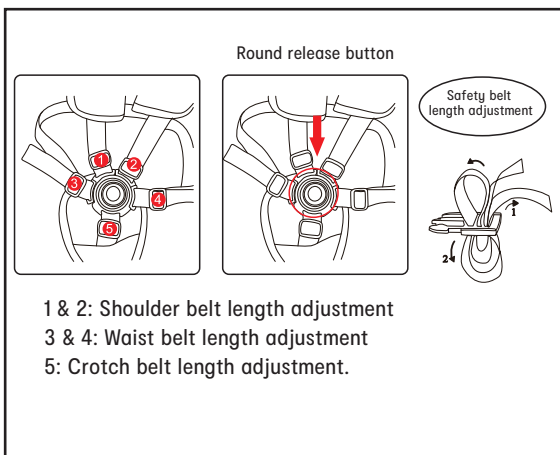

1 & 2: Shoulder belt length adjustment

3 & 4: Waist belt length adjustment

5: Crotch belt length adjustment.

The shoulder straps of the 5-point harness have 2 attachment positions. Select the position that places the shoulder strap level with, or below the top of the child's shoulder.

To adjust harness height unhook the shoulder strap from the crotch buckle. Feed the shoulder strap through the harness slots. You can access these slots from the rear of the seat underneath the fabric. Feed shoulder straps through the appropriate slots and reattach the shoulder straps to the crotch buckle.

TO FOLD THE STROLLER

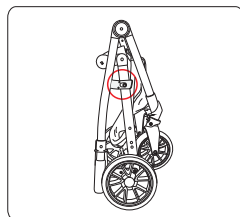
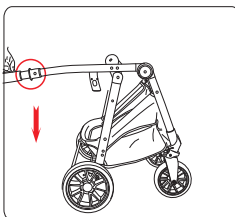
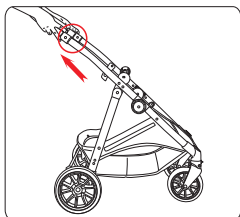

Remove the seat from the frame.

Fold the stroller by pulling both release triggers and press handle towards the floor.

Note: Fold the stroller from upright position. Fold down so the handle is level with the rear wheels, secure with the locking latch on the side of the frame before lifting.

Care and Maintenance

General

This stroller was designed and manufactured with quality materials and craftsmanship. Always use the safety harness.

Always check your stroller. Lubricate moving parts regularly, especially the wheels, and the lower parts of chassis that tend to collect dirt.

Inspect regularly for:

- Worn parts, torn materials or stitching.
- Loose screws, bent or broken frame parts.
- Broken, damaged or missing parts.

Should any of the above be evident, do not use. Any additional replacement parts should only be obtained from the manufacturer or distributor.

Care and Maintenance:

Seat/ Basket/ Canopy:
Wipe clean with a damp cloth.
It is not recommended to expose to salt water.
Rinse with fresh water immediately.

Do not fold or store the product while wet and never store in a damp environment as this can cause mildew to form.
Allow to dry thoroughly after washing and before storage.

Made in China

Keycode 42967767

FOR AU / NZ: IMPORTED FOR KMART STORES IN AUSTRALIA AND NEW ZEALAND.