

Assembly Instructions







42968665 EXTENDABLE SHOE RACK

ATTENTION:

DO NOT TIGHTEN THE SCREWS UNTIL THE PRODUCT IS FULLY ASSEMBLED. FOR INDOOR USE ONLY.

MAXIMUM SAFE LOAD: 3KG PER TIER.

Hardware list

	A	6X35mm	12PCS
	B	Hex Key	1PC
	C	Strap	1PC
	D	Wall Plug	1PC
	E	4X35mm	1PC
	F	Grip fastener	2PCS

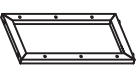
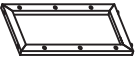
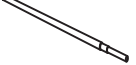
	①	Bamboo Frame	1PC
	②	Bamboo Frame	1PC
	③	Tube	6PCS

WARNING:

IF STACKING THE SHOE RACKS, IT IS STRONGLY RECOMMENDED THAT THE PRODUCT IS PERMANENTLY FIXED TO THE WALL. REGULARLY CHECK THAT ANCHORS ARE SECURELY MAINTAINED.

CAUTION: for your safety, when attaching the anchor fixings, please note the following:

Check any electrical wires or plumbing inside the wall before drilling any holes (if you are unsure please seek professional advice from a qualified tradesperson).



TOPPLING HAZARD

WARNING: PLEASE SECURE YOUR FURNITURE WITH THE SUPPLIED WALL FIXING. SCAN THE CODE FOR MORE INFORMATION.

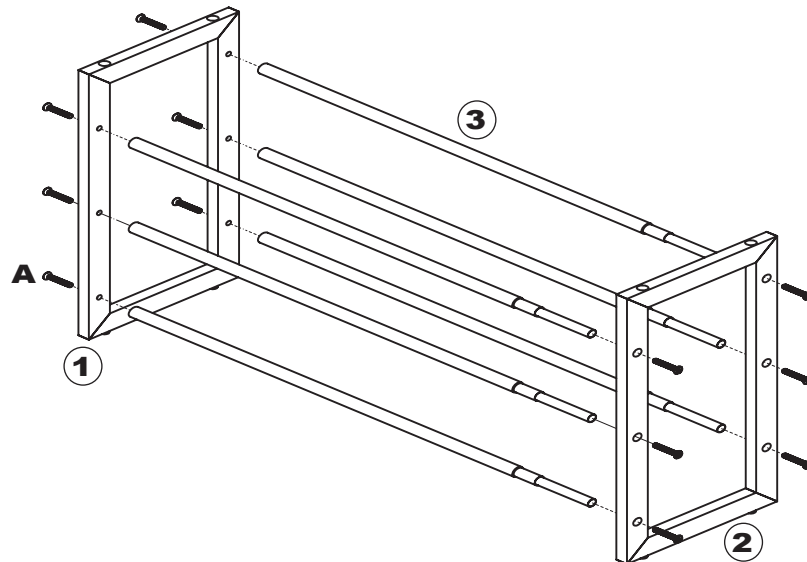

STEP 1

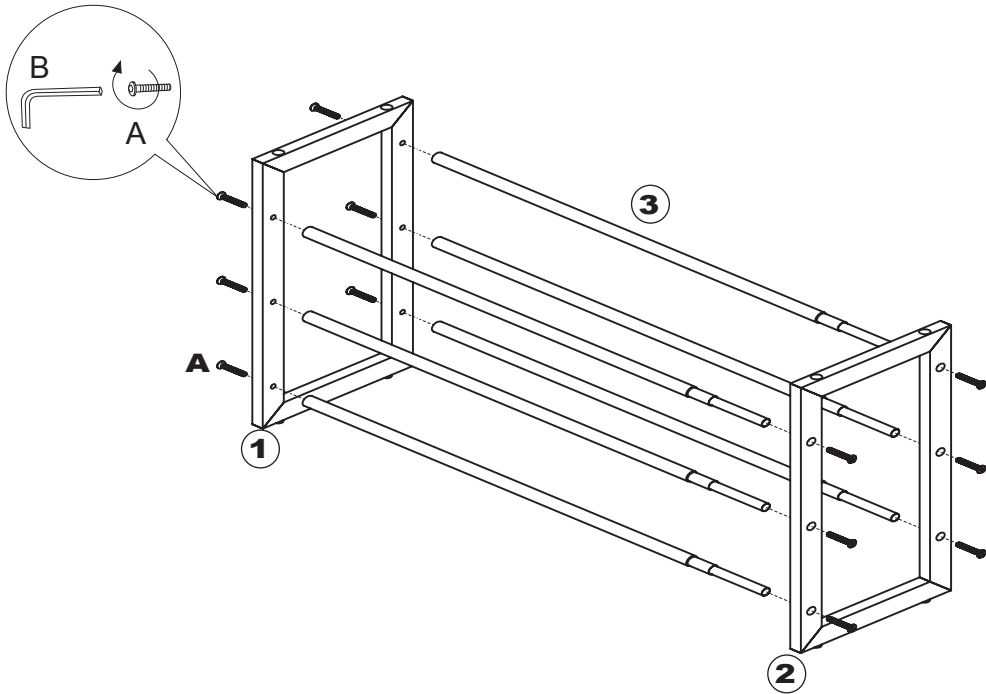

STEP 2

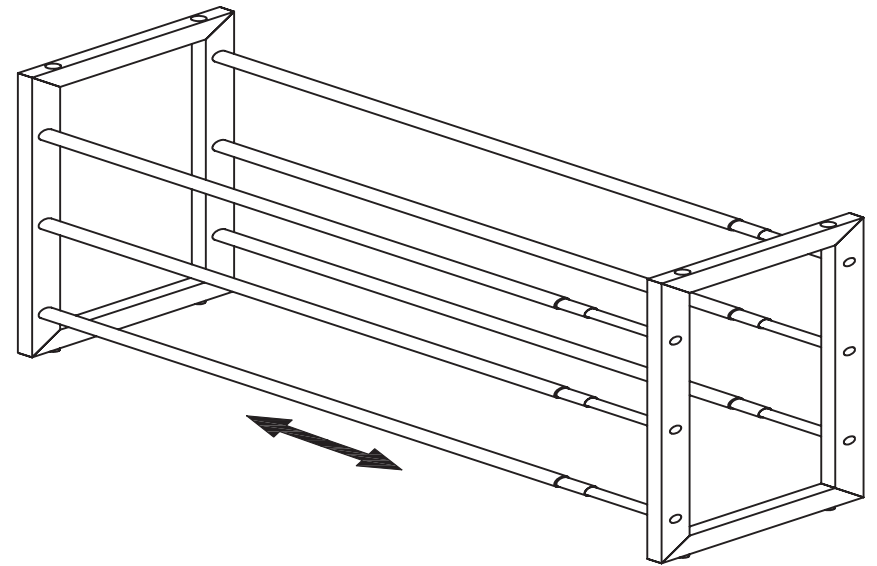

Optional Stacking STEP 3

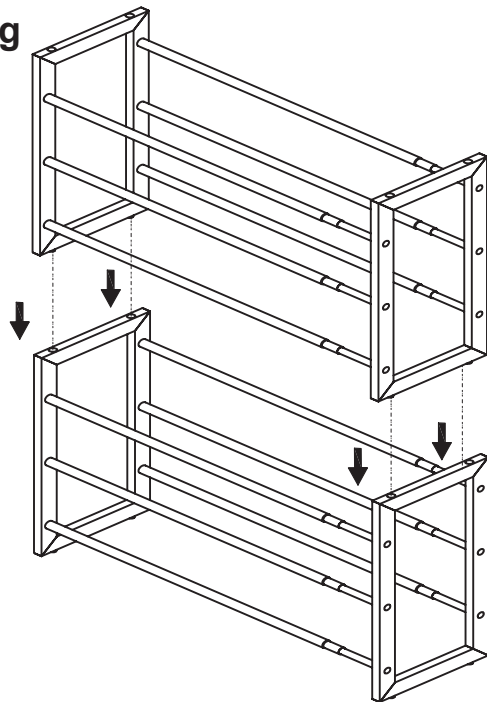

STEP 4

