

**anko**

# CO-SLEEPER BASSINET

**0-6**  
months

**9**  
kg

MAXIMUM  
WEIGHT

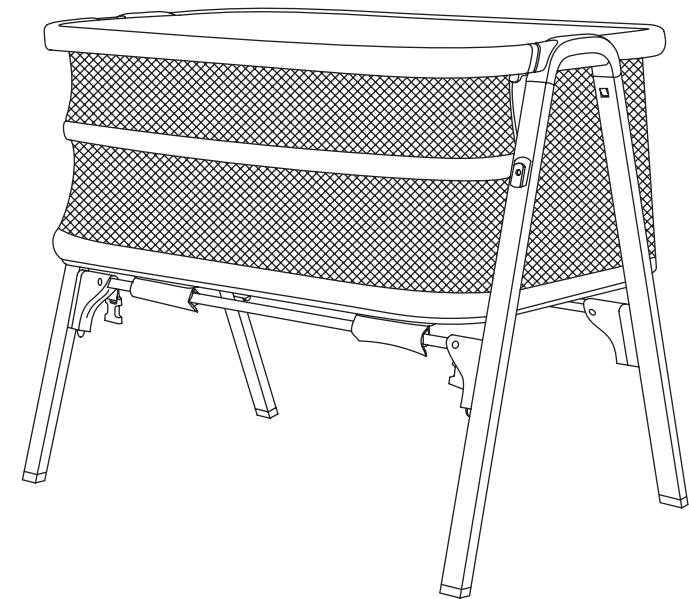

**IMPORTANT:  
RETAIN FOR FUTURE  
REFERENCE  
READ CAREFULLY**

Made in China

Keycode 42969266

The illustrations shown in this manual are for reference only. The manufacturer reserves the right to change any specification or feature without further notice.

IMPORTED FOR KMART STORES IN AUSTRALIA AND NEW ZEALAND.

**anko**

## Introduction:

This product has been designed and developed with safety, comfort and functionality in mind. Please take the time to read this manual carefully before using this product and keep it in a safe place for future reference.

The Co-Sleeper Bassinet allows you and your baby to sleep beside each other without the need to share the same bed. The contemporary and versatile design can be used either as a co-sleeper or a standalone bassinet.

Easily attaches to your bed with quick release straps and a drop-down side. Perfect when you're breastfeeding and keeping baby close for their first 6 months.

The Co-Sleeper Bassinet is compatible with most standard bed types and includes a bag for transport and/or storage.

### **Specifications:**

Age suitability: Birth to approx. 6 months  
Weight limit: 9 kg

## Maintenance:

Always check parts regularly for tightness of bolts, nuts and other fasteners - tighten or replace if required.

Check the strength of the fabric covers periodically. Defective or worn parts must be replaced; as should components which are broken, torn, defective or worn out. Use only parts and accessories approved by the manufacturer.

## Cleaning:

Spot clean the mattress and Co-Sleeper Bassinet using mild soap or upholstery shampoo.

NEVER use bleach. Air dry in shade thoroughly before reuse and avoid direct heat and sunlight. DO NOT iron. DO NOT dry clean.

Check the resistance of the fabric and the stitching after cleaning.

Wipe the frame using warm water and a mild detergent. NEVER use bleach. Never clean any part of the product with abrasive, ammonia based, bleach based or spirit type cleaners.

Ensure the product is fully dry before use or storage.

Always ensure the product is stored in a dry place to prevent mould or mildew developing. Store away from any heat sources and direct sun.

## Safety Precautions:

### **WARNINGS:**

IMPORTANT - RETAIN FOR FUTURE REFERENCE - READ CAREFULLY.

**WARNING!** BEFORE USE, REMOVE AND DISPOSE OF ALL PLASTIC BAGS AND PACKAGING MATERIALS AND KEEP THEM OUT OF REACH OF CHILDREN.

**WARNING!** This product is intended for use for babies aged between 0 and 6 months, weighing up to a maximum of 9kg.

**WARNING!** When a child is able to sit, kneel or to pull itself up, the Co-Sleeper Bassinet shall not be used anymore for this child.

**WARNING!** Do not use the product if any part is broken, torn or missing.

**WARNING!** Be aware of the risk of open fires and other sources of strong heat, such as electric bar fires, gas fires etc.

- Before assembly, check that the product and all of its components have not been damaged during transportation. Should any part be damaged, do not use and keep out of reach of children.

- Make sure the users of this product are knowledgeable on its proper operation.

**WARNING!** The product is ready for use only when all locking mechanisms are engaged. Check carefully that these are engaged before use.

**WARNING!** When the child is left unattended in the product, in “bassinet mode”, always make sure that the side rail is raised and the zips are completely closed.

- All opening, adjusting, anchoring and positioning operations of the product must be carried out exclusively by an adult.

- Before use in “co-sleeping mode” (fixed to bed) , make sure the product is properly anchored and positioned.

**WARNING!** When the product is used in “co-sleeping mode” (fixed to bed), before laying the child in it, make sure that the connection belts are hooked and tensioned properly. The product must be secured to the adult mattress and no gaps between the product and the adult mattress must be present.

- The product must always be placed on a horizontal surface. Never leave the product on an inclined surface with the child inside of it.

- Children must not be permitted to play near the product without supervision.

- Do not use the product without the frame.

- Keep the fastening belts away from the reach of children.

- Only use the mattress supplied by the manufacturer.

## Safety Precautions:

- The thickness of the mattress must be such that the vertical height (upper surface of the mattress until the upper edge of the product's sides) is at least 200mm.
- Do not use more than one mattress in the product.
- The reference mark on the product's interior indicates the maximum thickness of the mattress that shall be used.
- Do not leave any object inside the product that could reduce its depth.
- Do not position the product near walls and obstacles to prevent trapping hazards.
- Do not leave small objects inside the product to prevent choking hazards.
- Use only spare parts approved by the manufacturer. Do not apply accessories to the product, which are not supplied by the manufacturer.
- Do not adjust the product with the child inside.
- Do not move the product with the child inside.
- Do not use the product for more than one child at a time.
- The product must be kept away from electric cables and cords: do not place the product near windows where cords, curtains or similar objects could pose choking or strangulation hazards for the child. To avoid strangulation hazards, do not give to your child or place near her/him, objects equipped with cords.
- All assembly fittings should be tightened properly and care should be taken to ensure no screws are loose, as a child could trap parts of their body or clothing e.g. strings, necklaces, ribbons etc. which could pose a risk of strangulation.
- A prolonged exposure to the sun may cause changes of tones to the product's colour. After prolonged exposure of the product to high temperatures, wait a few minutes prior to placing your child in it.
- When not in use, keep the product away from the reach of children.

### CO-SLEEPING MODE (FIXED TO BED)

- The side support of the Co-Sleeper Bassinet should always be put close to the adult mattress and the mattress should always be aligned with the height of the side support for restraint of the Co-Sleeper Bassinet. Furthermore, the Co-Sleeper Bassinet should be firmly fixed to the structure of the adult bed or to the mattress support.

**WARNING!** Check to make sure that the Co-Sleeper Bassinet in the “co-sleeping mode” does not interfere with the adult bed.

**WARNING!** Use the Co-Sleeper Bassinet with the tube lowered, only in “co-sleeping mode” (fixed to bed).

## Storage/Transport:

A bag (F) is included for easier carrying, transportation or storage. Dismantle the Co-Sleeper Bassinet before inserting into the bag.

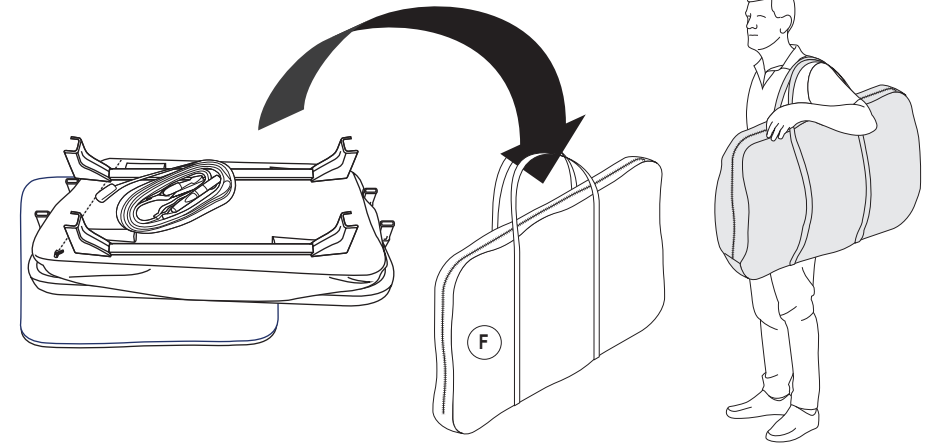

## To Raise the Side Rail:

**Step 3.** Insert the rail into the two upper anchor points, from top to bottom, until you hear the safety “click”. Fully close the vertical zips to finish the rail raising process.

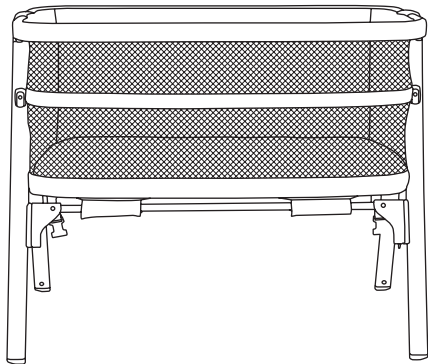
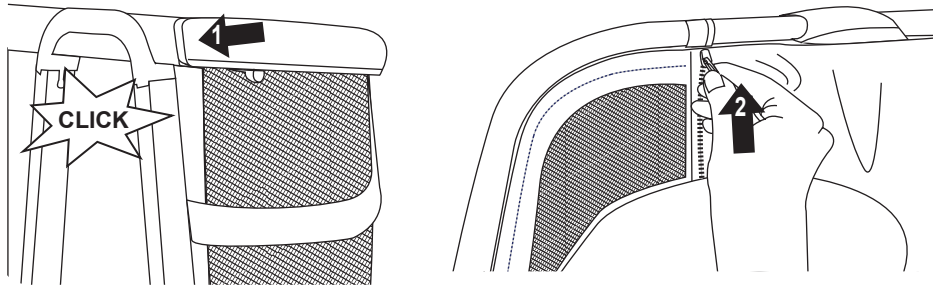

## Safety Precautions:

**WARNING!** The height of the adult mattress should always be more than that of the side support for containment of the Co-Sleeper Bassinet.

**WARNING!** Before every use, always check to make sure that there is no space between the adult mattress and the side of the Co-Sleeper Bassinet. On a regular basis, check the condition of the product and the presence of any possible damage. In the case of damage, do not use it and keep it out of reach of children.

**This bedside Co-Sleeper Bassinet must only be used with standard type beds with the mattress, box springs and frame all in line.**

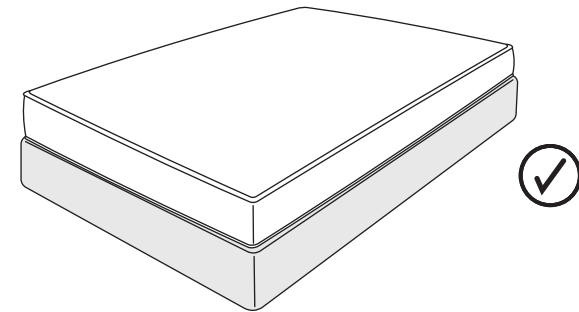

**DO NOT** use the bedside sleeper with platform beds or atypical shape beds:

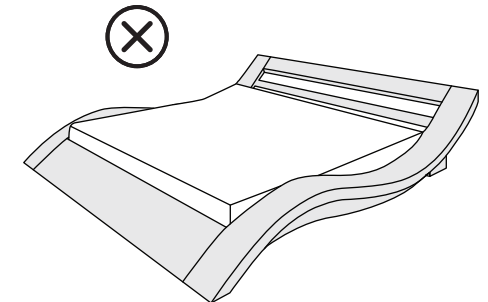
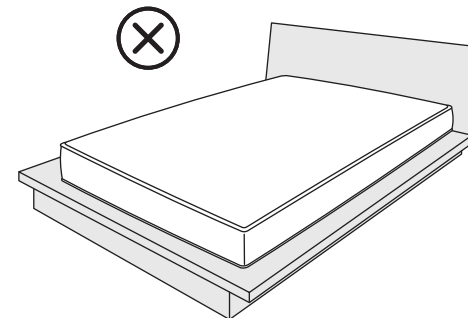

# Parts:

## Check what you have received:

You have received 1 box. Please check the contents of the box against the list below. If anything is missing, please contact Customer Service.

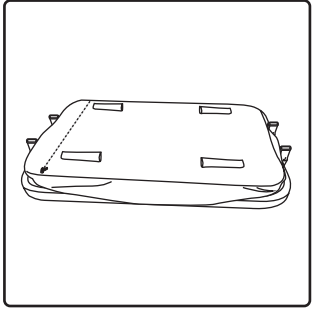

(A) Co-Sleeper Bassinet body  
x1

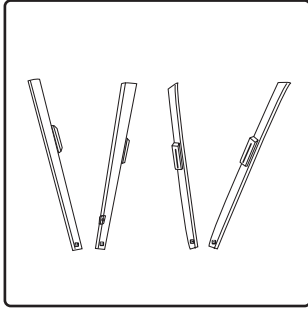

(B) vertical legs  
x4

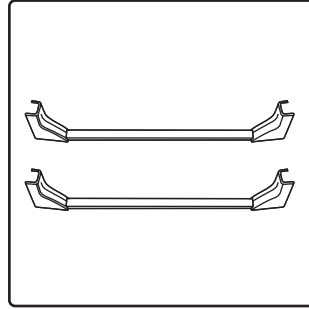

(C) crosspiece bar  
x2

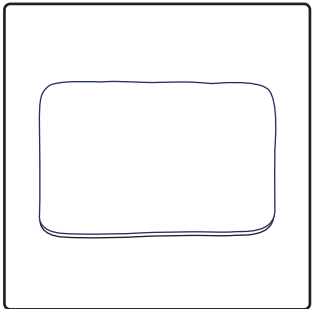

(D) mattress  
x1

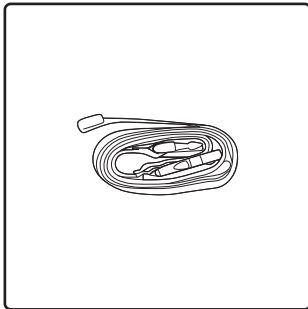

(E) "co-sleeper" belts  
x2

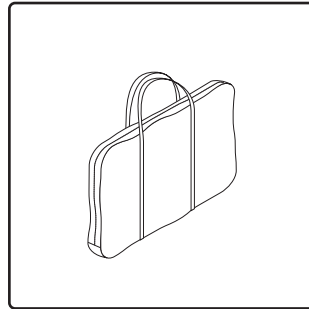

(F) bag  
x1

# To Raise the Side Rail:

**Step 1.** Open the horizontal zip and remove the surplus netting along the rail under the zip.

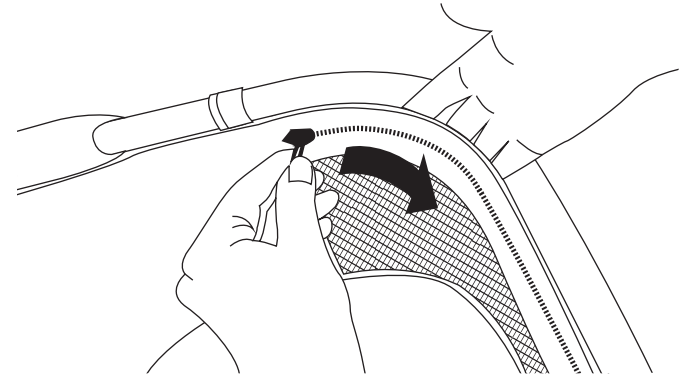

**Step 2.** Unlock the safety rail on both sides at the same time. Slide buttons with your finger and move the rail upwards to take it out of the two lower anchor points.

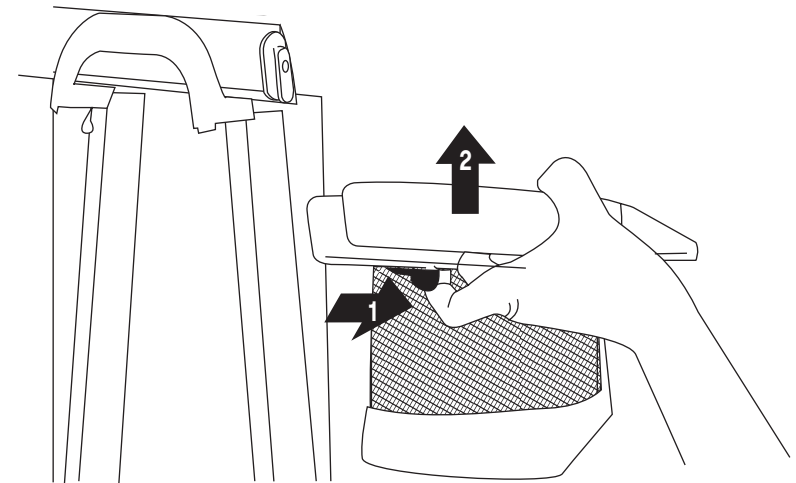

# Co-Sleeper (Fixed to Bed):

**Step 9.** Check the height of the Co-Sleeper Bassinet against the adult mattress and adjust as required.

**WARNING!** The height of the adult mattress should always be more than that of the side support for containment of the Co-Sleeper Bassinet.

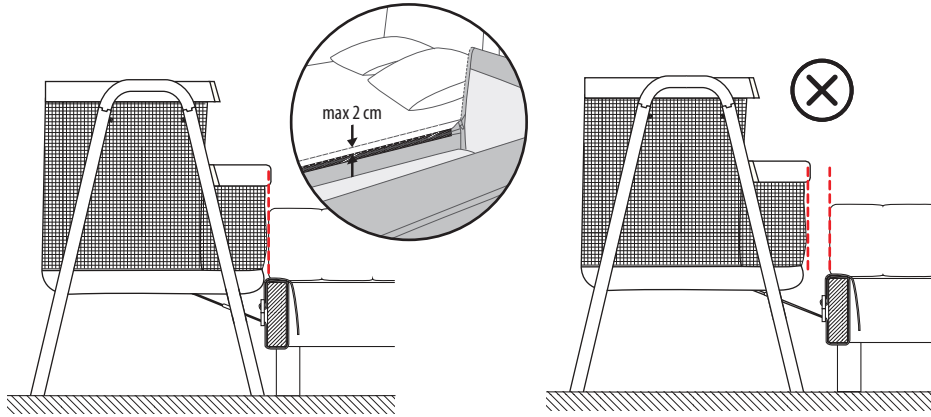

**WARNING!** Before every use, always check to ensure that there is no space between the adult mattress and the side of the Co-Sleeper Bassinet. If there is, pull the belts firmly to tighten until there is no space and the required condition of use has been restored.

**WARNING!** During use, ensure that the adult bed sheets, blankets etc. do not enter and cover the interior of the Co-Sleeper Bassinet.

**WARNING!** Never use the Co-Sleeper Bassinet without the side rail fully locked into the two lower anchor points.

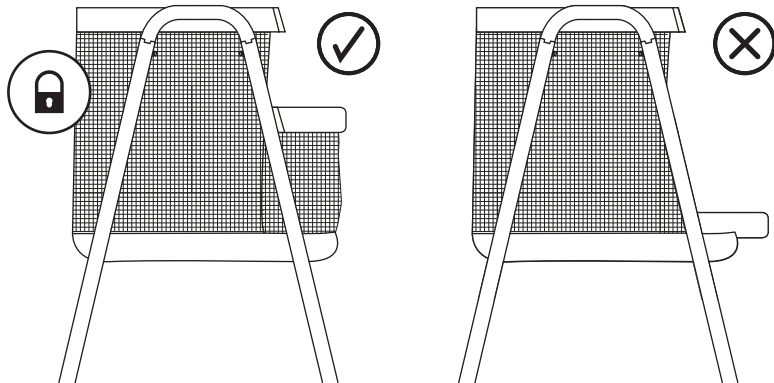

# Assembly:

**Step 1.** Remove the mattress (D) and place the Co-Sleeper Bassinet (A) face down on a table or clean, flat surface.

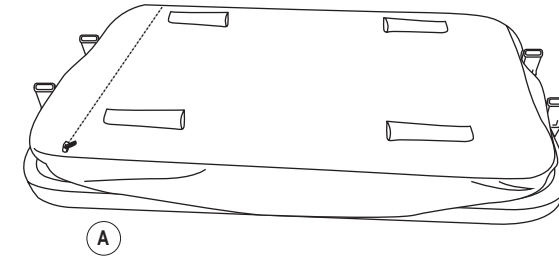

**Step 2a.** Insert the vertical legs (B) into the plastic supports, aligning the holes at the side of the legs with the plastic support connectors.

Follow the order marked by the letters A B C D. The letter on the leg should match up with the letter on the plastic support A-A, B-B, C-C, D-D.

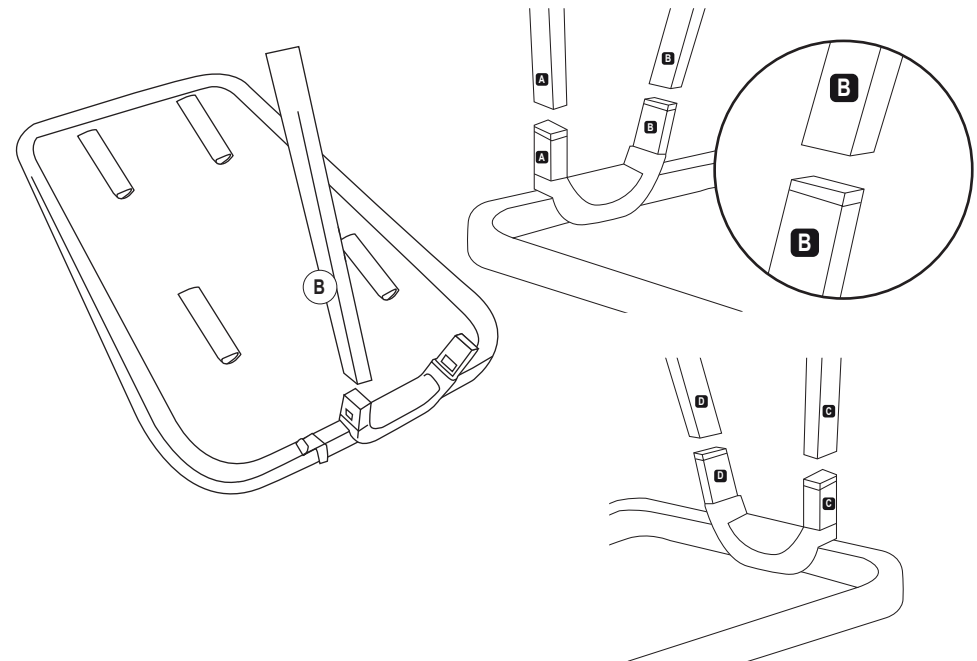

## Assembly:

**Step 2b.** To fasten the leg correctly in place, press downwards until you hear the safety “click” and repeat the same process with the other legs.

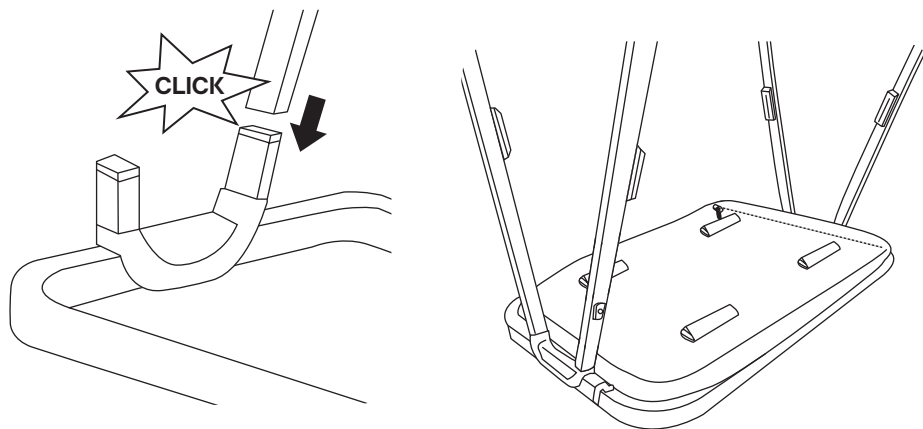

**Step 3a.** Fit one crosspiece bar (C) by simultaneously inserting the two side connectors upwards into the guides until they slot in fully. Insert them from the bottom to the top until they both “click” into place.

**Step 3b.** Repeat the same process with the second crosspiece bar.

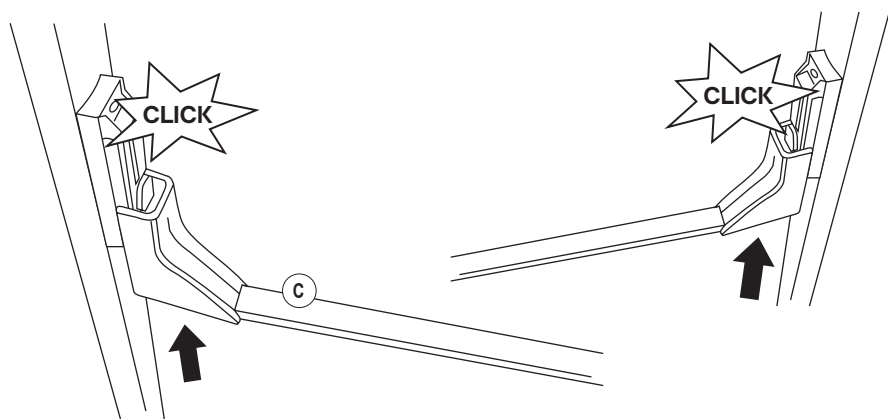

## Co-Sleeper (Fixed to Bed):

**Step 7.** Pull on the loose end of the belt to ensure it is secure and tight around the adult bed frame.

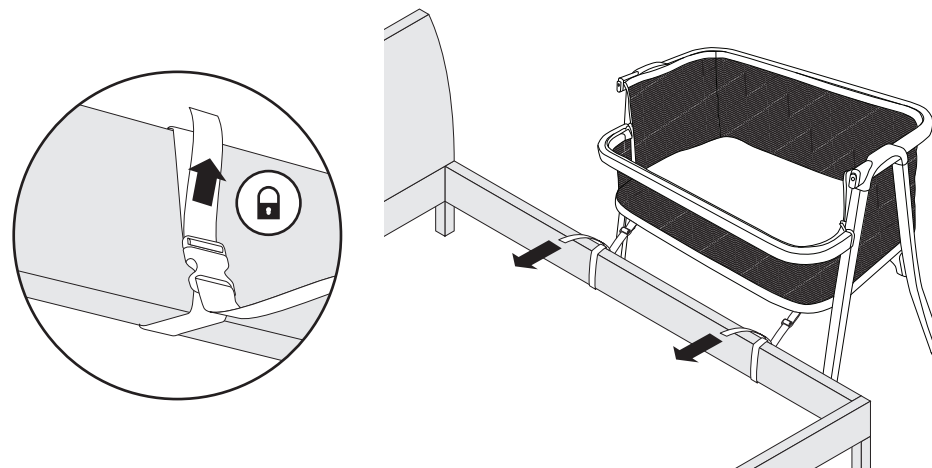

**Step 8.** Adjust the sliders to shorten and tighten the belts; they must be rigid with no slack. The Co-Sleeper Bassinet should be right up against the adult bed with no gaps.

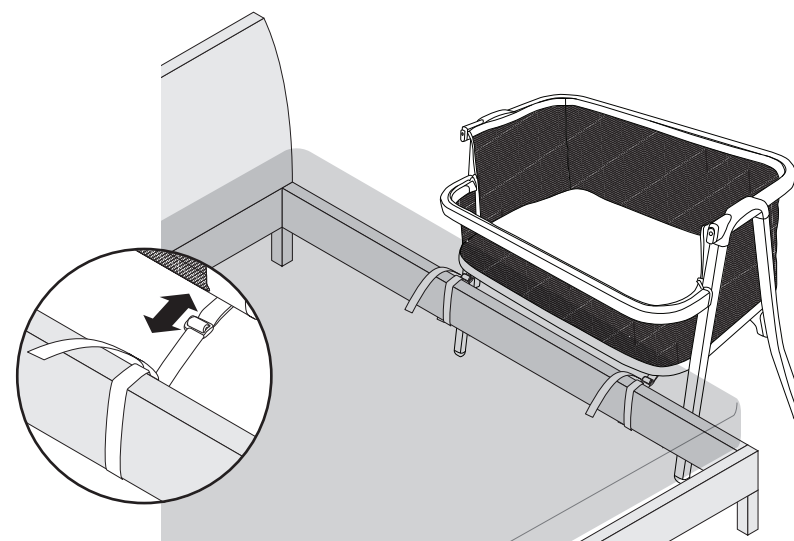



## Co-Sleeper (Fixed to Bed):

**Step 5.** Use the “co-sleeper” belts (E) provided to fix the Co-Sleeper Bassinet to the adult bed. Attach the buckles underneath the Co-Sleeper Bassinet on both sides.

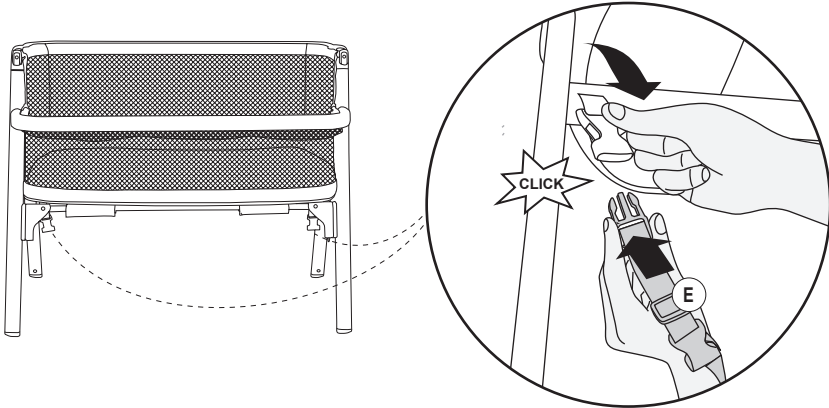

**Step 6a.** Wrap the belts around the frame of the adult bed, from the bottom towards the top.

**Step 6b.** Fasten the buckles around the adult bed frame.

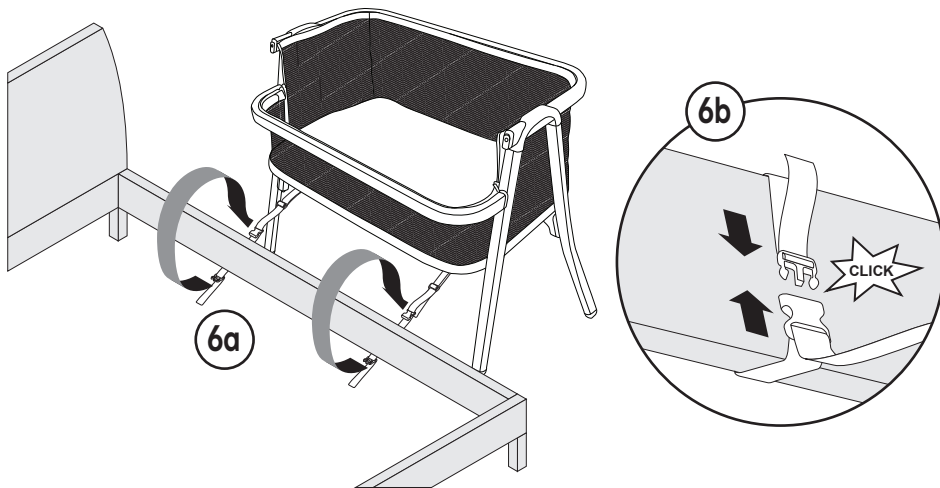

## Assembly:

**Step 4.** Turn the Co-Sleeper Bassinet over and insert the mattress (B). Fasten the 4 hook and loop flaps around the crosspiece bars, making sure that they are fully secure.

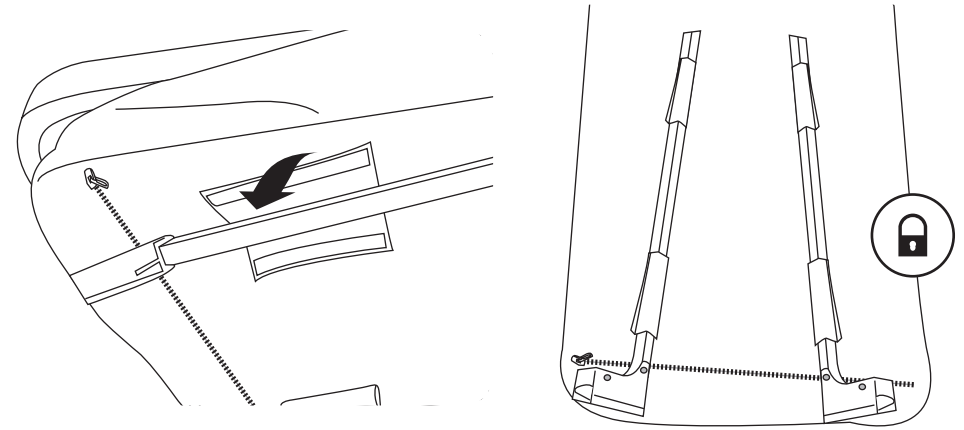

To dismantle the Co-Sleeper Bassinet, follow the same process in reverse.

## Co-Sleeper (Fixed to Bed):

**Step 1.** Undo the zips to open the drop side. Ensure they are fully open.

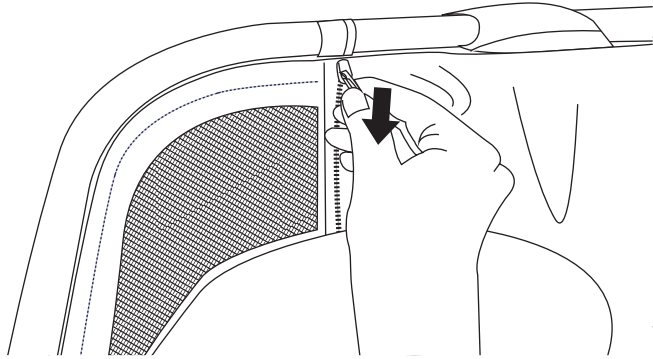

**Step 2.** Unlock the side rail; at the same time on both sides, slide the buttons with your finger and move the rail upwards to take it out of the guide.

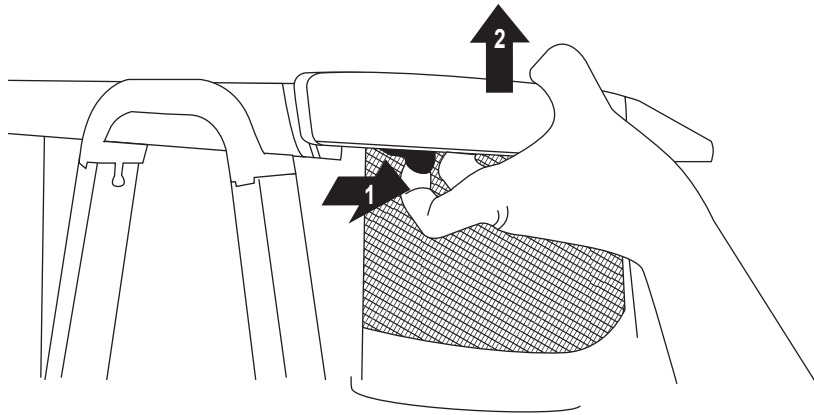

## Co-Sleeper (Fixed to Bed):

**Step 3.** Insert the rail into the two lower anchor points, until you hear the safety “click”.

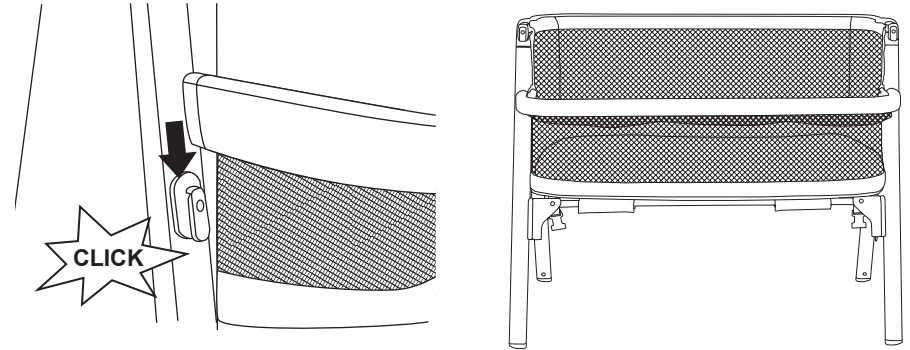

**Step 4.** Conceal all the surplus netting along the rail under the zip. Fully close the horizontal zip to finish the rail lowering process.

**WARNING!** If the child is left alone in the Co-Sleeper Bassinet, always make sure that the drop side is raised.

