

Assembly Instructions



42971085 3 TIER CADDY WITH WHEELS



ATTENTION:

DO NOT TIGHTEN THE SCREWS UNTIL THE PRODUCT IS FULLY ASSEMBLED. FOR INDOOR USE ONLY.

MAXIMUM SAFE LOAD: 3KG PER TIER.

Hardware list

	A	8X23mm	16PCS
	B	Wheels	4PCS

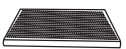
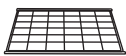
	①	Side Frame	2PCS
	②	Side Frame	2PCS
	③	Top Shelf	1PC
	④	Shelf	3PCS

STEP 1

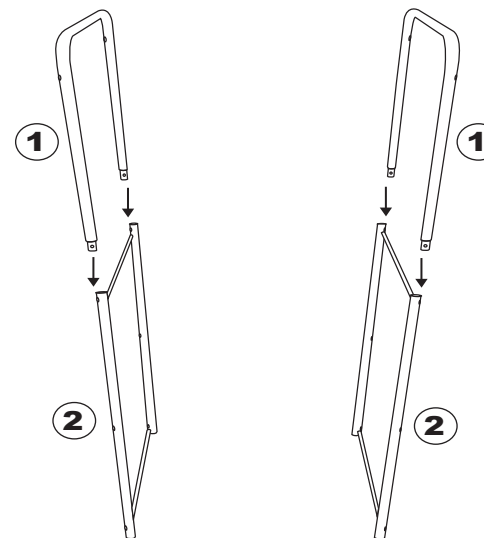

STEP 2

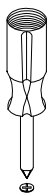
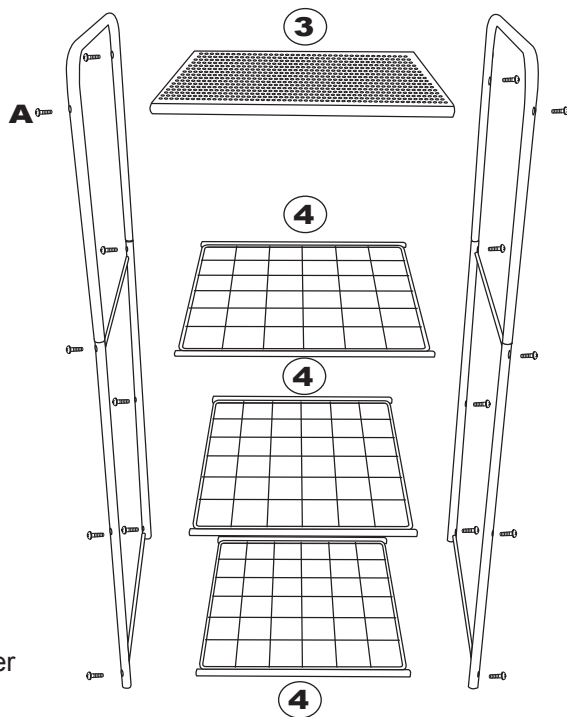

Tool required
Philips Head Screw Driver
(Not Provided)

STEP 3

