

# Assembly Instructions

## CARE INSTRUCTIONS:













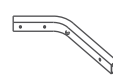



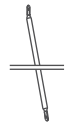







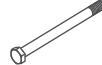

WIPE CLEAN WITH A SOFT DAMP CLOTH. DO NOT USE SCOURERS, ABRASIVES OR CHEMICAL SOLVENTS TO CLEAN THE EQUIPMENT. CHECK AND TIGHTEN ALL PARTS REGULARLY. REPLACE ANY DAMAGED PARTS IMMEDIATELY. STORE IN A DRY PLACE AND KEEP AWAY FROM SUNLIGHT. FOR INDOOR AND DOMESTIC USE ONLY.

## WARNING:

ADULT ASSEMBLY REQUIRED. THIS EQUIPMENT MUST BE USED ON A LEVEL AND STABLE GROUND. DO NOT USE THE EQUIPMENT AS A STEP LADDER. DO NOT USE THE EQUIPMENT UNLESS ALL BOLTS AND SCREWS ARE FIRMLY SECURED. CHECK AND TIGHTEN ALL PARTS REGULARLY. DO NOT DRAG THIS EQUIPMENT. THIS PACKAGE CONTAINS SMALL PARTS. KEEP CHILDREN AWAY WHEN ASSEMBLING. KEEP UNSUPERVISED CHILDREN AWAY FROM THE EQUIPMENT. INJURIES MAY RESULT FROM INCORRECT OR EXCESSIVE TRAINING. IMMEDIATELY STOP THE EXERCISING, IF YOU FEEL SICK OR FEEL ANY DISCOMFORT DURING USE ,IF ANY ABNORMAL SOUNDS ARE HEARD YOU SHOULD CEASE USING THE EQUIPMENT UNTIL ITS RESOLVED. THE SAFETY LEVEL OF THE EQUIPMENT CAN BE MAINTAINED ONLY IF IT IS EXAMINED REGULARLY FOR DAMAGED PARTS AND WEAR AND TEAR.

**USE AGE:14+. MAXIMUM USE WEIGHT FOR BOXING BAG: 60KG. PRODUCT WEIGHT: 25.30KG. FAILURE TO FOLLOW THESE WARNINGS COULD RESULT IN SERIOUS INJURY. FOR AU / NZ: IMPORTED FOR KMART AUSTRALIA LIMITED. STORE IN AUSTRALIA AND NEW ZEALAND. LEVEL 4/690 SPRINGVALE ROAD, MULGRAVE VICTORIA AUSTRALIA 3170**

## PART LIST

1  1PC	2  2PCS	3  1PC	4  1PC
5  1PC	6  1PC	7  1PC	8  1PC
9  1PC	10  4PCS	11  1PC	12  2PCS
13  1PC	14  1PC	15  1PC	16  M10 34PCS
17  M10*150 2PCS	18  M10*65 9PCS	19  M10*60 2PCS	20  M10 17PCS
21  M6 4PCS	22  M6 spring washer-- 4PCS	23  M6*25 4PCS	24  M10*70 4PCS
25  M10*50 1PC	26  M10 1PC	27  M10 BIG 1PC	28  1PC
29  1PC			

**Step 1:** Fix part 10 on part 1 & 2 with screws 16, 18 & 20 (as below per diagram).

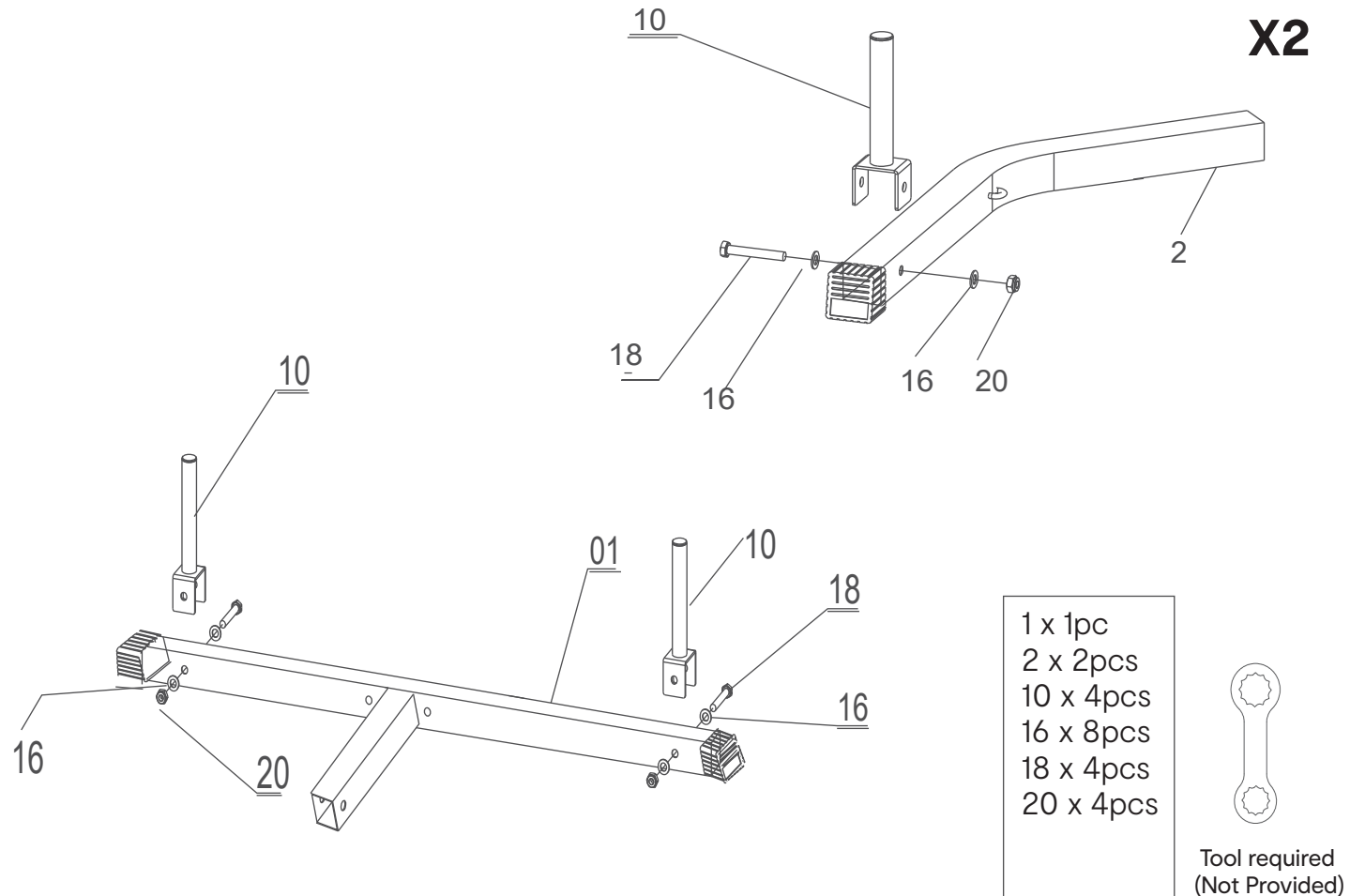

**Step 2:** Fix tube 2 & 3 into tube 1 with screws 16, 17, 20 & 24 (as below diagram).

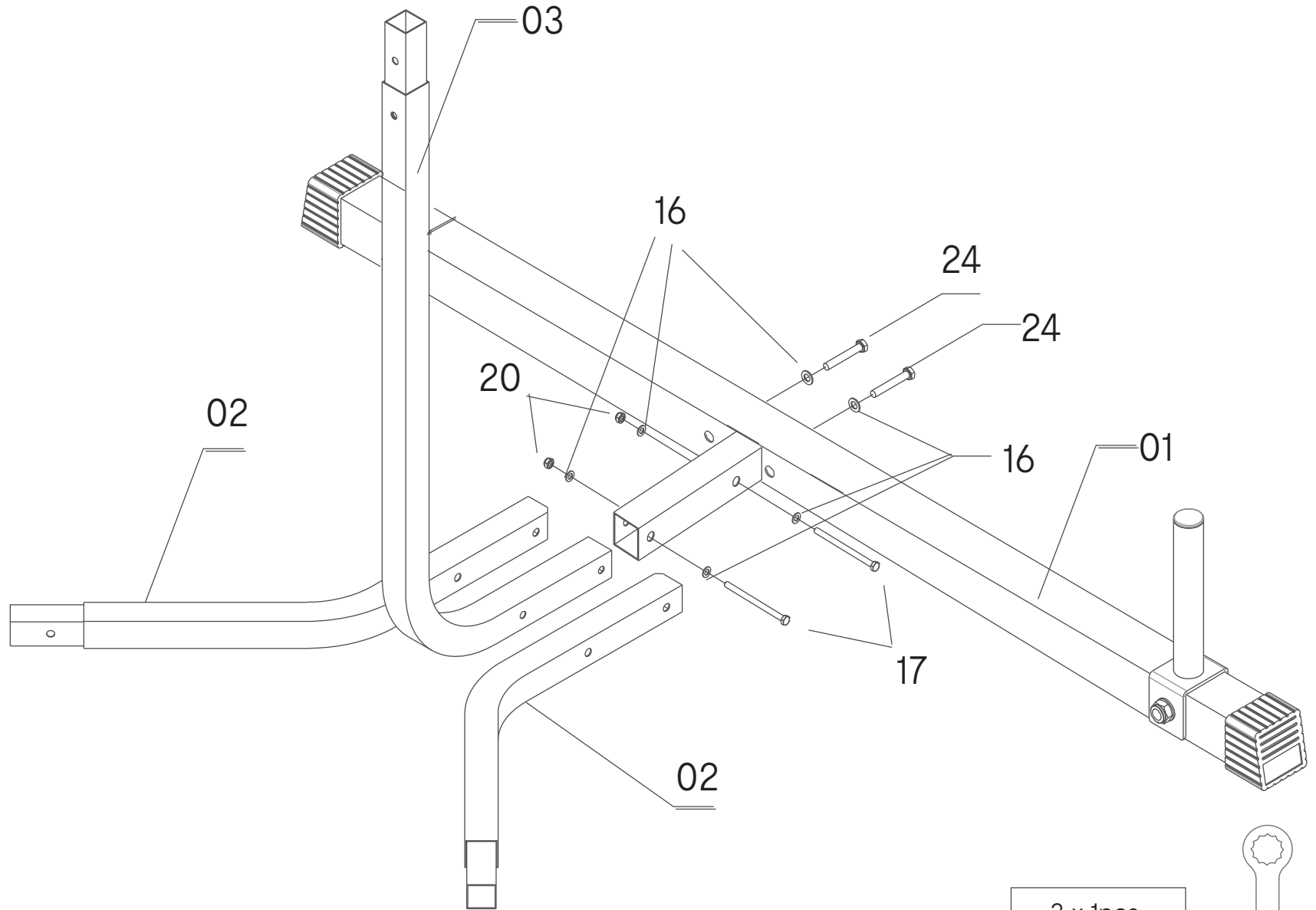

- 3 x 1pcs
- 16 x 6pcs
- 17 x 2pcs
- 20 x 2pcs
- 24 x 2pcs

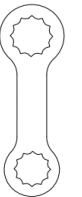

Tool required  
(Not Provided)

**Step 3:** Do not tighten all the screws until the assembly is complete.

- a. Fix part 13 on part 14 with screws 21, 22 & 23. Connecting this part to tube 7 with screws 16, 20 & 24(as below diagram).
- b. Insert tube 7 into tube 6 and use part 15 to fix and adjust height of part 7.
- c. Fix part 26 with screws 20 & 27.
- d. Connecting tube 3, tube 6 & part 12 with screws 12, 16, 18 & 20(as below diagram)..

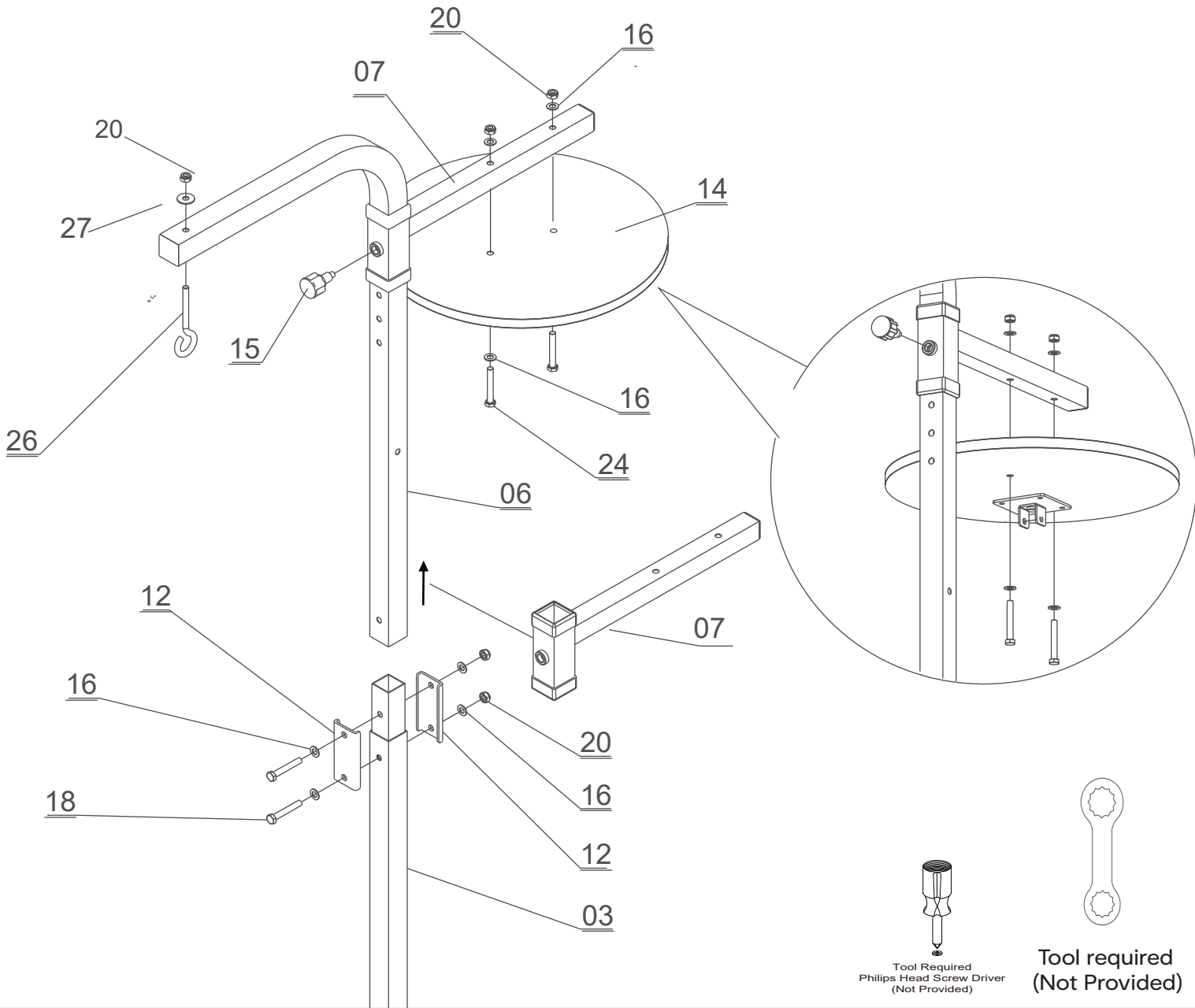
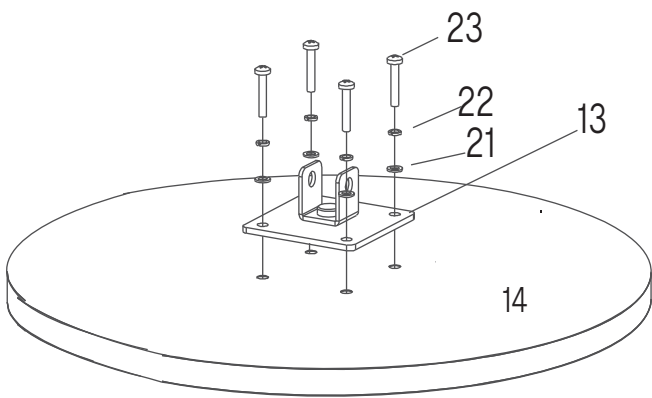

- 6 x 1pc
- 7 x 1pc
- 12 x 2pcs
- 13 x 1pc
- 14 x 1pc
- 15 x 1pc
- 16 x 8pcs
- 18 x 2pcs
- 20 x 5pcs
- 21 x 4pcs
- 22 x 4pcs
- 23 x 4pcs
- 24 x 2pcs
- 26 x 1pc
- 27 x 1pc

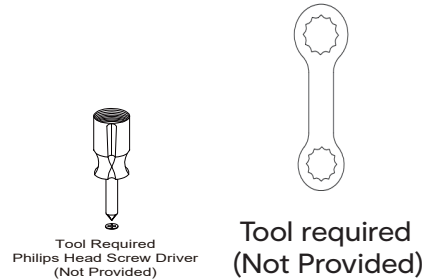

**Step 4:**

- a. Connecting tube 8, 9 & 11 to tube 4 & 5 with screws 16, 18 & 20.
- b. Connecting tube 4 & 5 with tube 2 with screws 16, 19 & 20, fix tube 8 & 9 to tube 6 with screws 16, 18 & 20.
- c. Using screws 16, 20 & 25 to hanging the speed ball, hanging the boxing bag on part 26.

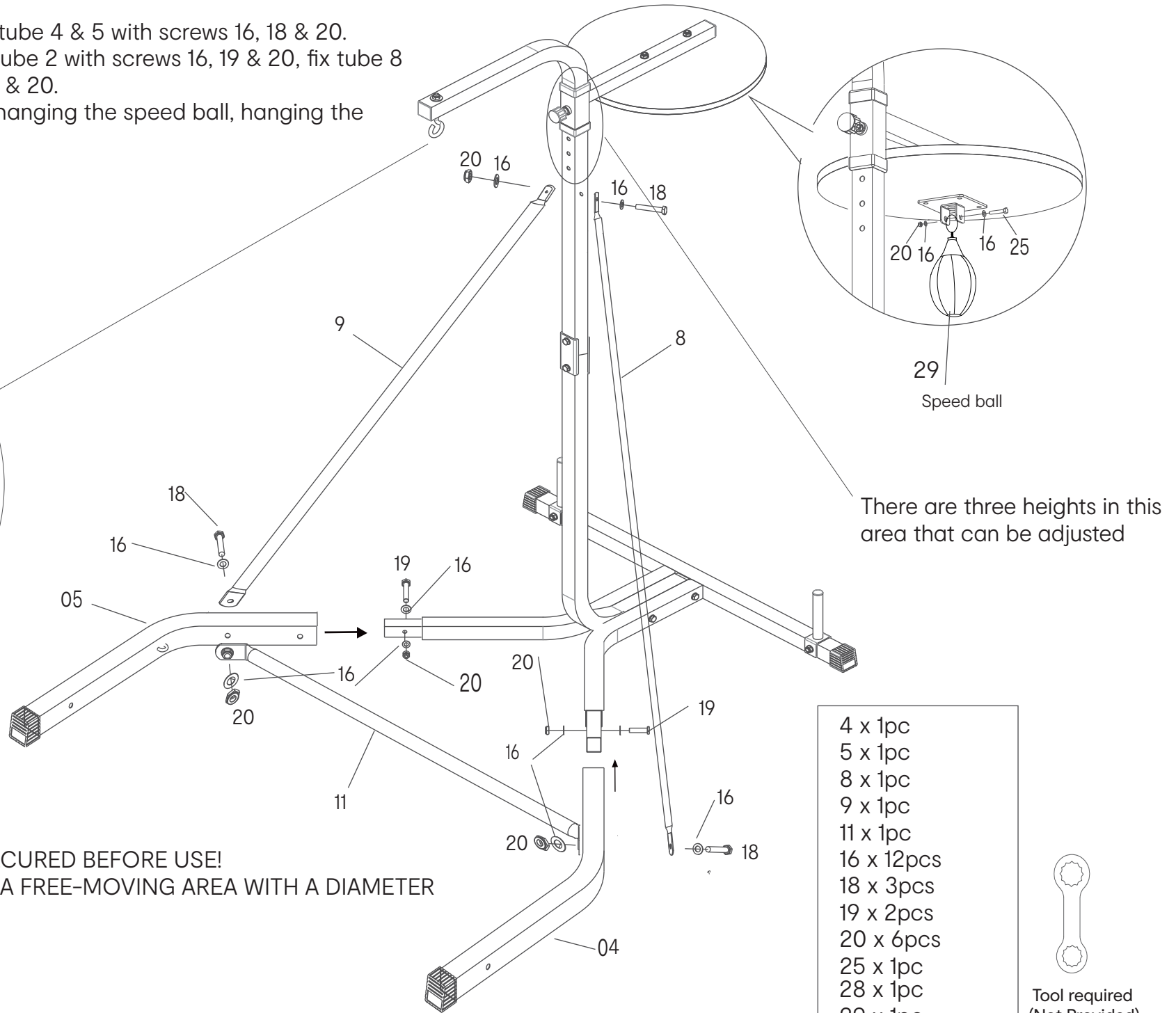
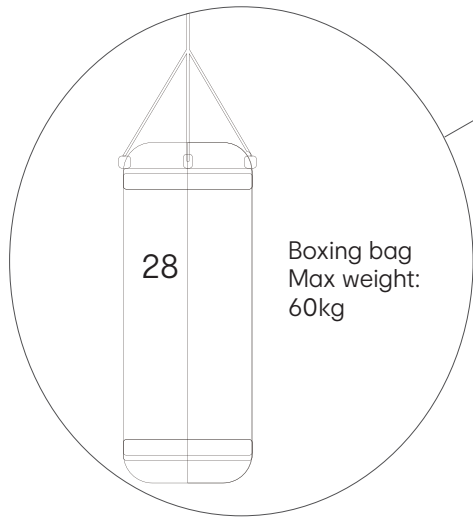

- 4 x 1pc
- 5 x 1pc
- 8 x 1pc
- 9 x 1pc
- 11 x 1pc
- 16 x 12pcs
- 18 x 3pcs
- 19 x 2pcs
- 20 x 6pcs
- 25 x 1pc
- 28 x 1pc
- 29 x 1pc

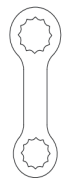

Tool required  
(Not Provided)

**WARNING:**  
1. ALL THE SCREWS MUST BE SECURED BEFORE USE!  
2. IT IS NECESSARY TO ENSURE A FREE-MOVING AREA WITH A DIAMETER OF 1 METERS.

**Product Size:**

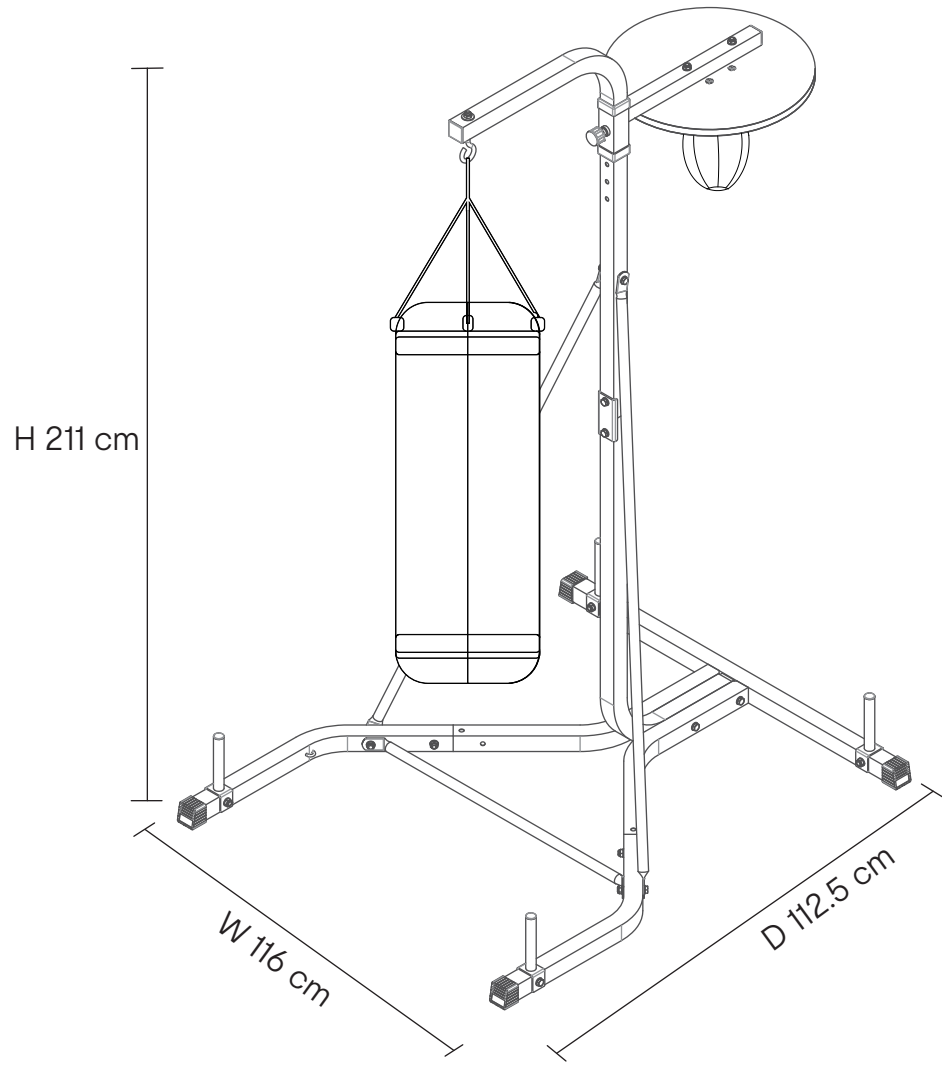

**Free move area**

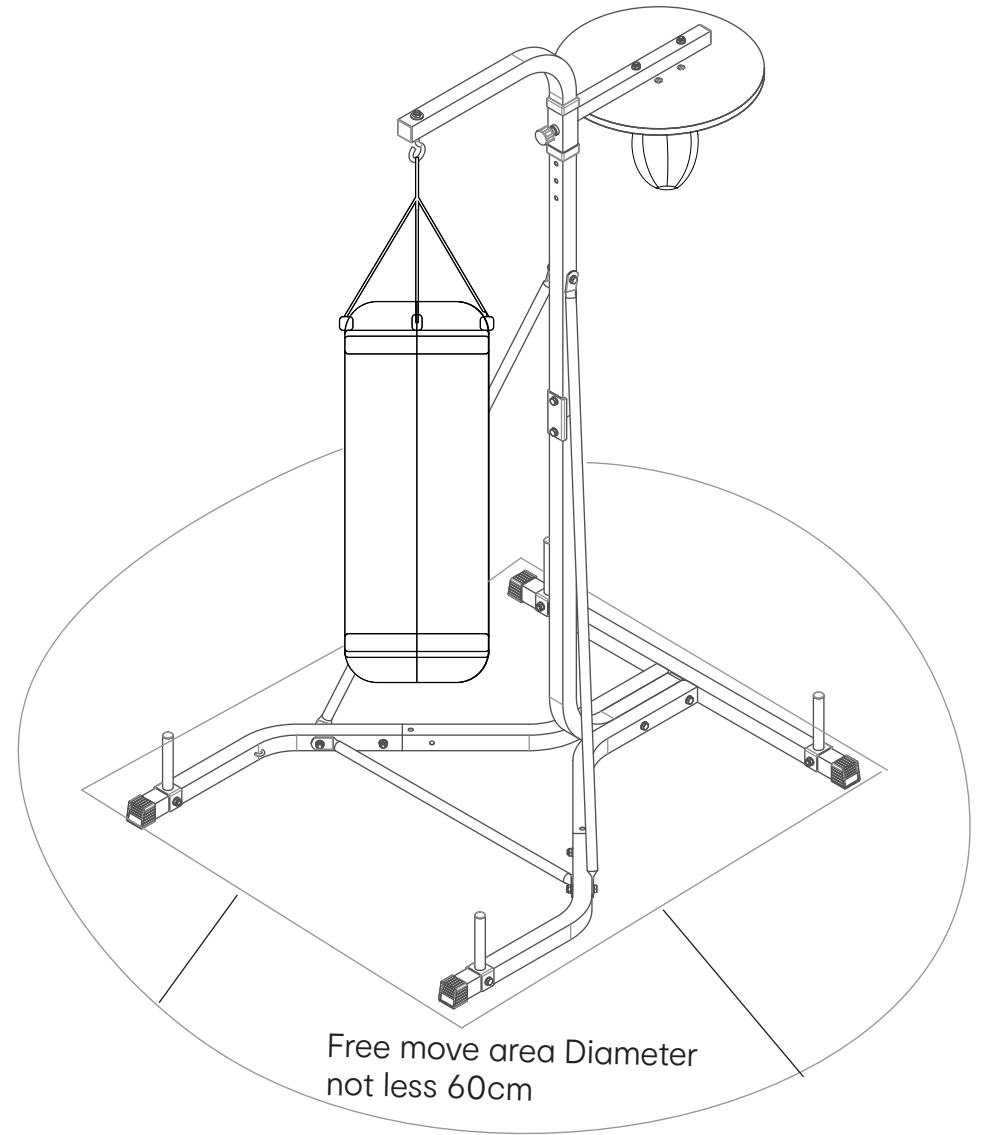

**WARNING:**

1. Need to add load weights (not included) in the specified position when using this equipment.
2. load weights (not included) in the specified position when using this equipment.
3. Max loading weight of boxing bag is 60kg.
4. boxing gloves not included.

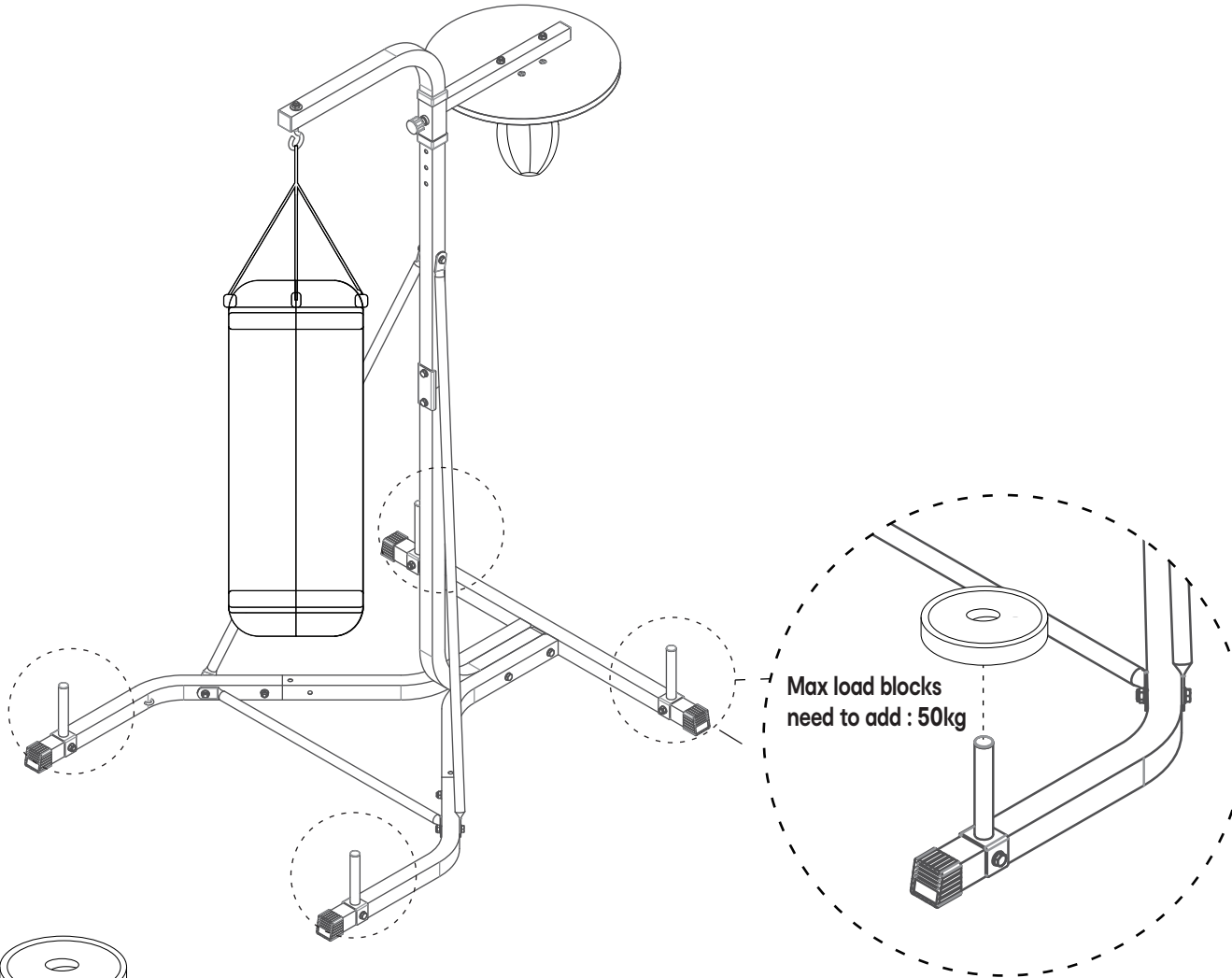

load weights  
(not provided)

