

anko

Toaster

T3225AE

USER MANUAL

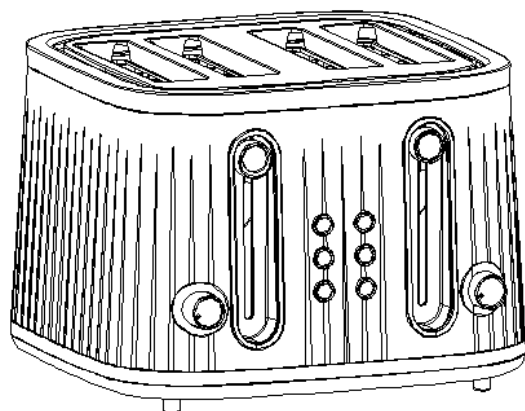

**PLEASE READ AND SAVE THESE
INSTRUCTIONS FOR FUTURE REFERENCE**

IMPORTANT INSTRUCTIONS

1. Please read these instructions before operating and retain for future reference.
2. This appliance is not intended for use by persons (including children) with reduced physical, sensory or mental capabilities, or lack of experience and knowledge, unless they have been given supervision or instructions concerning use of the appliance by a person responsible for their safety.
3. Children should be supervised to ensure that they do not play with the appliance.
4. If the supply cord is damaged, it must be replaced by the manufacturer, its service agent or similarly qualified persons in order to avoid a hazard.

5. The bread may burn, therefore do not use the toaster near or below combustible material, such as curtains.

6. This appliance is not intended to be operated by means of an external timer or separate remote-control system.

7. For cleaning instructions refer to the section “Care and Cleaning”.

8. This appliance is intended to be used in household and similar applications such as:

- staff kitchen areas in shops, offices and other working environments;
- farmhouses;
- by clients in hotels, motels and other residential type environments;
- bed and breakfast type environments.

9. To protect against electrical hazard do not immerse any part of the appliance or cord in water or any other liquid.

10. Close supervision is necessary when the appliance is used near children.

11. Do not leave the appliance unattended when in use.

12. Always use the appliance on a dry, level surface.

13. Do not use this appliance outdoors.

14. Always disconnect from mains power when not in use and before cleaning.

15. For electrical safety, do not operate the appliance if damaged, after an appliance malfunction or it has been dropped.

16. Regular periodic close checks should be

carried out on the supply cord to ensure no damage is evident. Should there be any signs that the cord is damaged in the slightest degree, do not use. All repairs on the product should be carried out by qualified electrical person only or the product must be disposed.

17. Do not let the power cord hang over the edge of a table or counter or touch hot surfaces. Allow the unit to cool down before wrapping the cord around base for storage.

18. Care must be taken not to touch any hot surfaces. Do not store or cover the appliance until it has fully cooled down.

19. Do not place this appliance on or near a hot gas or electric burner, in or where it could touch a heated oven, or a microwave oven.

20. Do not use harsh abrasives, caustic cleaners or oven cleaners when cleaning this appliance.

21. When using this appliance, allow adequate air space above and on all sides for air circulation. Do not allow this appliance to touch curtains, wall coverings, clothing, dishtowels or other flammable materials during use. CAUTION is required on when used/placed on surfaces where heat may cause a problem – placing an insulated heat pad under the toaster is recommended to prevent heat damage to the surface.

22. Do not use the toaster without the crumb tray in place. The crumb tray should be cleaned regularly. Do not allow crumbs to build up in the tray.

23. IMPORTANT! Do not use the toaster with any food product containing sugar content or with products containing jam or preserves.

24. CAUTION: The temperature of accessible surfaces may be high when the appliance is operating and immediately after use.

WARNING!

Never attempt to extract jammed toast, muffins, bagels or any other item with a knife or any other metal object, as contact with live elements may cause electrocution.

Always allow the appliance to cool down, disconnect from mains power and carefully remove the bread.

WARNING!

Electric Shock Hazard. Do not attempt to dislodge food when toaster is in use or connected to mains power.

PRODUCT FEATURES

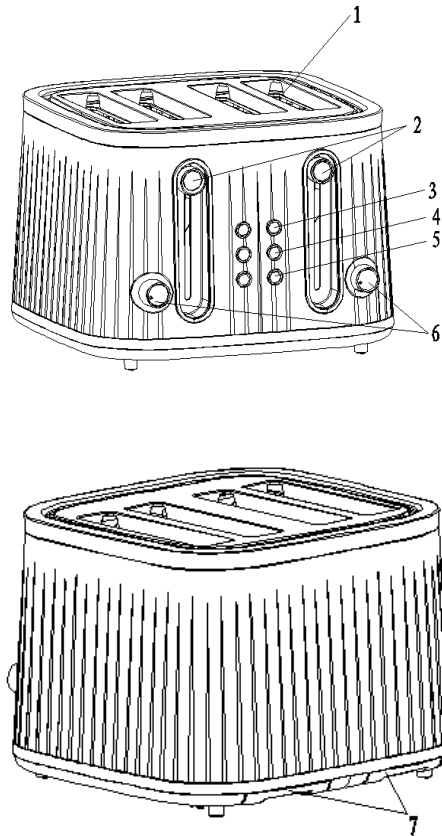

1. Variable width toasting slots
2. Carriage control lever
3. Cancel button.
4. Reheat button
5. Defrost button.
6. Electronic variable browning control.
7. Pull-out crumb tray.

WARNING! Do not leave the appliance unattended when in use. The bread may burn, therefore do not use the toaster near or below combustible material, such as curtains.

IMPORTANT! Do not use the toaster with any foodstuff product containing sugar content or with products containing jam or preserves.

OPERATING THE TOASTER

1. Insert the supply cord plug into a suitable mains power outlet socket and turn the power ON.
2. Before first use of the product, we recommend operating the toaster without bread four to five times at the highest toasting level. This way, any existing production residues will be removed. Then allow the toaster to cool down sufficiently before switching it ON again.
3. Place up to four slices of bread or muffins into bread slots.
4. Select the desired browning setting, from No.1 to No.6 on the browning control knob. (No.1-lightest, No.6-darkest).
5. When using the toaster for the first time, we suggest you toast on number 3.

-
6. Note: Varying types of bread and personal preference may require a different browning setting.
 7. Press the carriage control lever down until it clicks into place. Toasting cycle will automatically commence. Please note: if the toaster is not plugged in and switched on at the power point, the carriage control lever will not click into place.
 8. The toaster turns off when the desired toast color is achieved, and the toast is raised automatically. The toasting process can be stopped at any time by pressing the cancel button.

HIGH LIFT FUNCTION: TO REMOVE SMALLER ITEMS SUCH AS CRUMPETS AND MUFFINS, LIFT CARRIAGE CONTROL LEVER APPROXIMATELY 20MM ABOVE THE STARTING POSITION.

TOASTING FROZEN BREAD: To toast frozen bread, place the bread into the bread slots and select the desired browning setting. Press the carriage control lever down until it clicks into place, then press the defrost button.

REHEATING TOAST: The toaster allows you to reheat toast without additional toasting. To reheat, place toast into bread slots, lower the carriage control lever until it clicks into place, and press the reheat button.

In the unlikely event that the bread or crumpet becomes jammed, switch the toaster off from the mains power outlet socket and remove the plug. Then carefully ease the bread out of the toaster, ensuring that you do not damage the element.

CARE AND CLEANING

1. Always turn the power off, remove the plug from the mains power outlet socket and allow the toaster to cool before cleaning.
2. To remove any crumbs from the toaster, slide out the crumb tray from under the toaster, empty and fit it back in the toaster before using it again.
3. Wipe the outside of the toaster with a slightly dampened cloth and polish with a soft dry cloth.
4. Do not immerse the unit in water.
5. To clean the interior, turn the toaster upside down over the sink and shake crumbs free.

The crumb tray should be cleaned regularly. Do not allow breadcrumbs to accumulate in the bottom of the toaster.

TECHNICAL DATA

Voltage: 220-240V~ 50-60Hz

Power: 1900-2300W

12 MONTH WARRANTY

Thank you for your purchase from Kmart.

Kmart Australia Ltd warrants your new product to be free from defects in materials and workmanship for the period stated above, from the date of purchase, provided that the product is used in accordance with accompanying recommendations or instructions where provided. This warranty is in addition to your rights under the Australian Consumer Law.

Kmart will provide you with your choice of a refund, repair or exchange (where possible) for this product if it becomes defective within the warranty period. Kmart will bear the reasonable expense of claiming the warranty. This warranty will no longer apply where the defect is a result of alteration, accident, misuse, abuse or neglect.

Please retain your receipt as proof of purchase and contact our Customer Service Centre on 1800 124 125 (Australia) or 0800 945 995 (New Zealand) or alternatively, via Customer Help at Kmart.com.au for any difficulties with your product. Warranty claims and claims for expense

incurred in returning this product can be addressed to our Customer Service Centre at 690 Springvale Rd, Mulgrave Vic 3170.

Our goods come with guarantees that cannot be excluded under the Australian Consumer Law. You are entitled to a replacement or refund for a major failure and compensation for any other reasonably foreseeable loss or damage. You are also entitled to have the goods repaired or replaced if the goods fail to be of acceptable quality and the failure does not amount to a major failure.

For New Zealand customers, this warranty is in addition to statutory rights observed under New Zealand legislation.