

Assembly Instructions











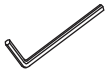

43019502 FOLDING STATION & HAMPER

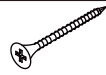

CARE INSTRUCTION: WIPE CLEAN WITH A SOFT DRY OR DAMP CLOTH. KEEP AWAY FROM WATER AND DIRECT SUNLIGHT. FOR INDOOR AND DOMESTIC USE. CHECK AND TIGHTEN ALL PARTS REGULARLY.

WARNING: DO NOT STAND OR SIT ON THE UNIT. DO NOT LEAN ON THE PRODUCT. DO NOT USE UNTIL ALL SCREWS, BOLTS AND KNOBS ARE FIRMLY SECURED. THIS PRODUCT CONTAINS SMALL PARTS AND SHARP POINTS, KEEP AWAY FROM CHILDREN AND BABIES.

ADULT ASSEMBLY REQUIRED. FAILURE TO FOLLOW THESE WARNINGS COULD RESULT IN SERIOUS INJURY. MAXIMUM TOTAL LOADING WEIGHT: 20KGS (5KG FOR EACH SECTION OF THE HAMPER AND 10KG FOR THE TABLE TOP).

Hardware list

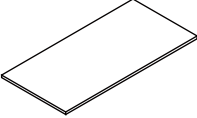
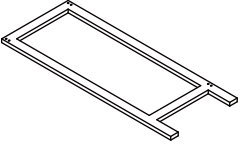
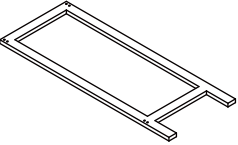
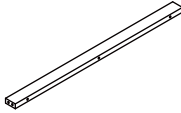
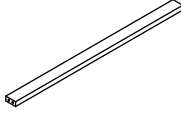
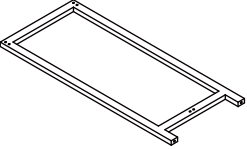
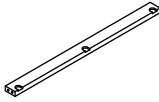
	a	5X40mm	24PCS		g	4X40mm	1PC
	b		1PC		h		1PC
	c		2PCS		i		1PC
	d		2PCS		j		2PCS
	e	4X35mm	6PCS		k	3X12mm	1PC
	f		1PC		Tool required Philips Head Screw Driver (Not Provided)		

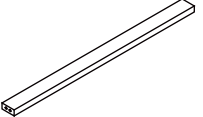
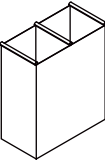
	A	1 PC		B	1 PC		C	1 PC
	D	2 PCS		E	1 PC		F	2 PCS
	G	2 PCS		H	3 PCS		I	1 PC
	J	1 PC						

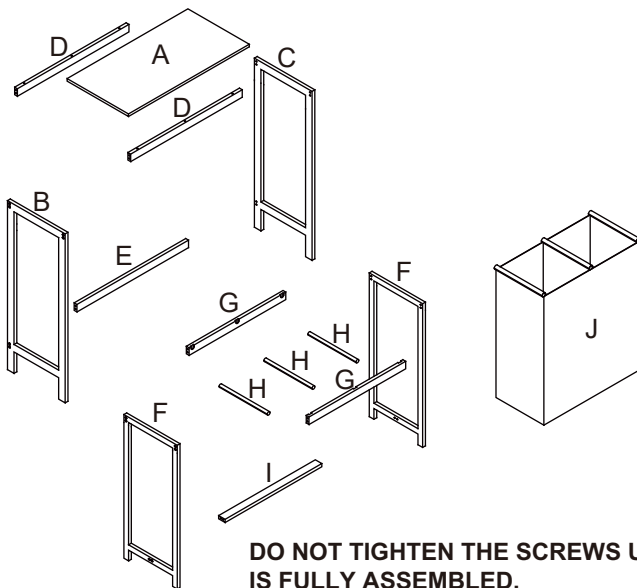

DO NOT TIGHTEN THE SCREWS UNTIL THE PRODUCT IS FULLY ASSEMBLED.

STEP 1

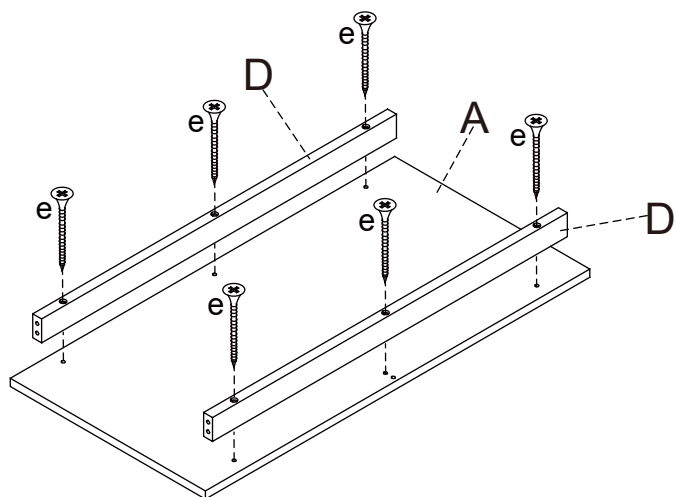

 e X 6

STEP 2

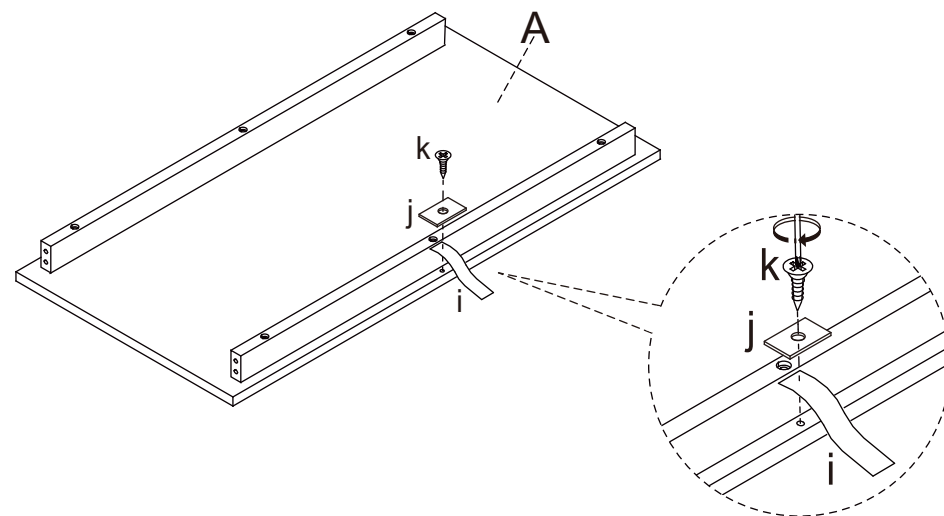

 i X 1  j X 1  k X 1

STEP 3

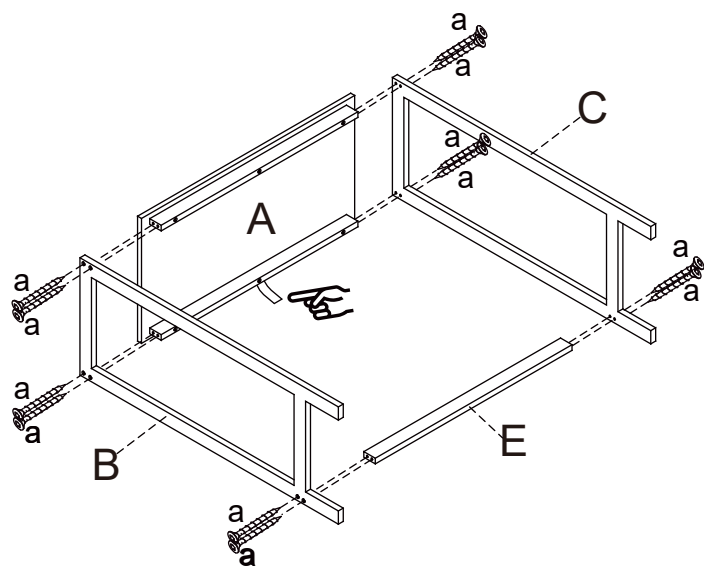

 a X 12

STEP 4

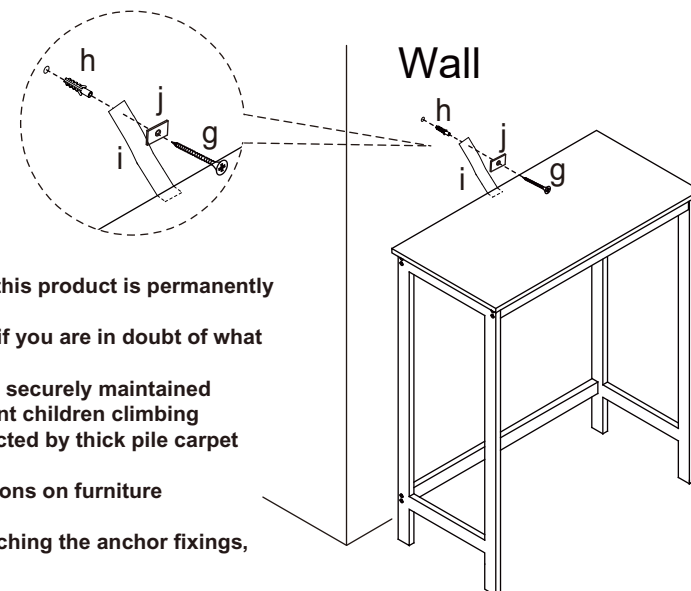

Warning:

- It is strongly recommended that this product is permanently fixed to the wall.
- Please seek professional advice if you are in doubt of what fixing device to use.
- Regularly check that anchors are securely maintained
- Use safety drawer locks to prevent children climbing
- Stability of tall items may be affected by thick pile carpet or uneven floors
- Do not place unanchored televisions on furniture

Caution: for your safety when attaching the anchor fixings, please note the following:

- Check any electrical wires or plumbing inside the wall before drilling any holes (if you are unsure please seek professional advice from a qualified tradesperson).

 g X 1  h X 1  j X 1

STEP 5

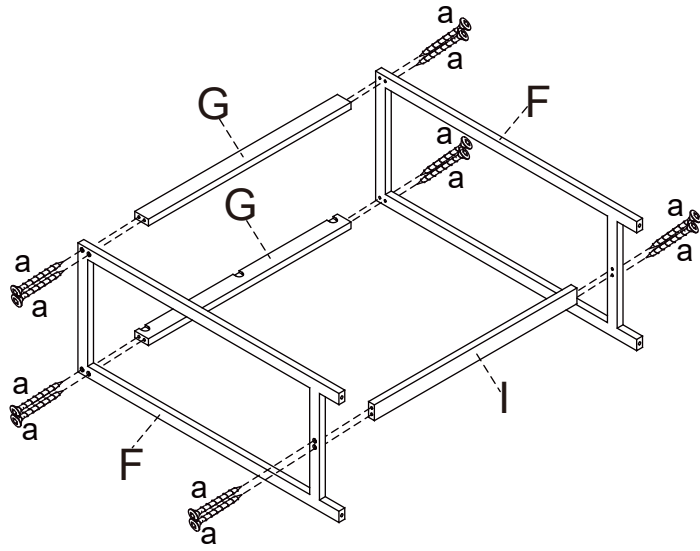

STEP 6

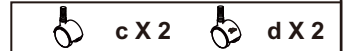
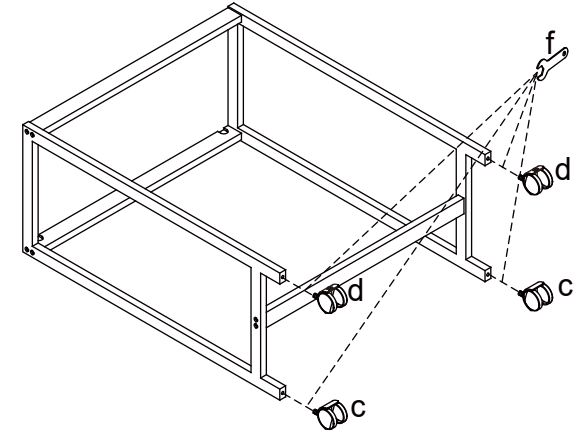

STEP 7

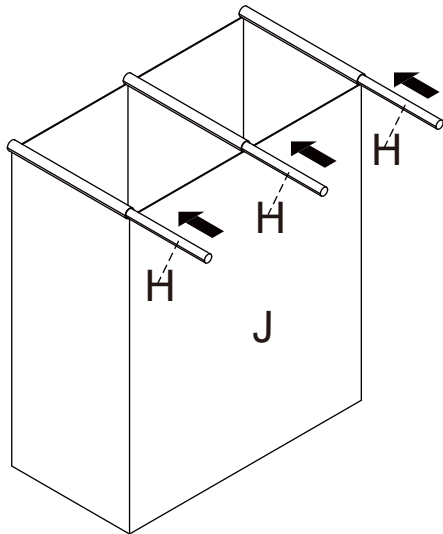

STEP 8

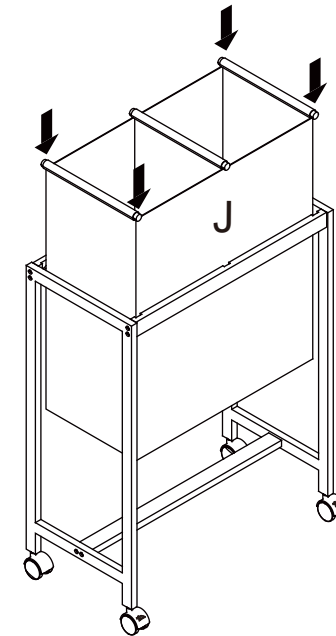

STEP 9

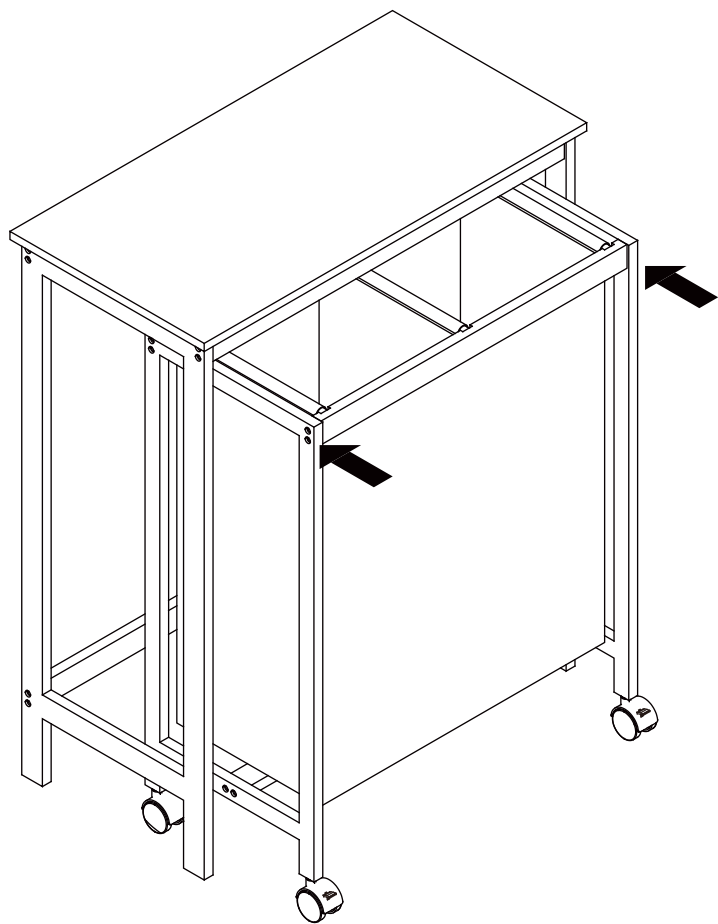

STEP 10

