







Assembly Instructions







43024230 SLATTED BAMBOO TALL SHELF WITH DOOR



WARNING: DO NOT USE THIS UNIT UNLESS ALL BOLTS AND SCREWS ARE FIRMLY SECURED. DO NOT KNOCK OR DRAG THIS UNIT. USE ONLY ON A FLAT SURFACE. FAILURE TO FOLLOW THESE WARNINGS COULD RESULT IN SERIOUS INJURY. THIS PACKAGE CONTAINS SMALL PARTS AND SHARP POINTS, KEEP AWAY FROM CHILDREN AND BABIES.

MAXIMUM TOTAL LOADING WEIGHT: 3KGS EACH SHELF, 15KGS IN TOTAL.

Hardware list

	a	5X30mm	16PCS
	b		1PC
	c		1PC
	d	4X20mm	2PCS
	e		2PCS
	f	3X12mm	12PCS

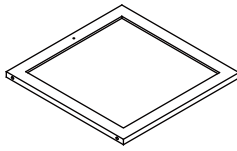
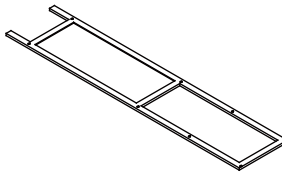
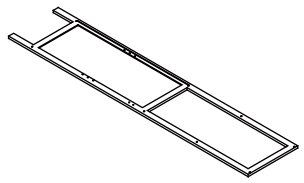
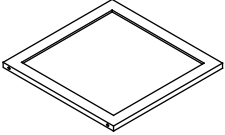
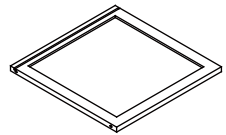
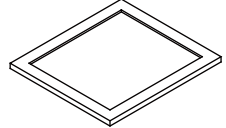
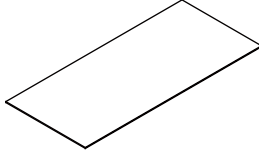
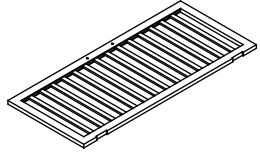
	g		4PCS
	h	4X15mm	1PC
	i	4X35mm	1PC
	j		1PC
	k		1PC
	l		2PCS
	m		1PC

	A	1PC		B	1PC		C	1PC
	D	1PC		E	2PCS		F	1PC
	G	1PC		H	1PC		I	1PC

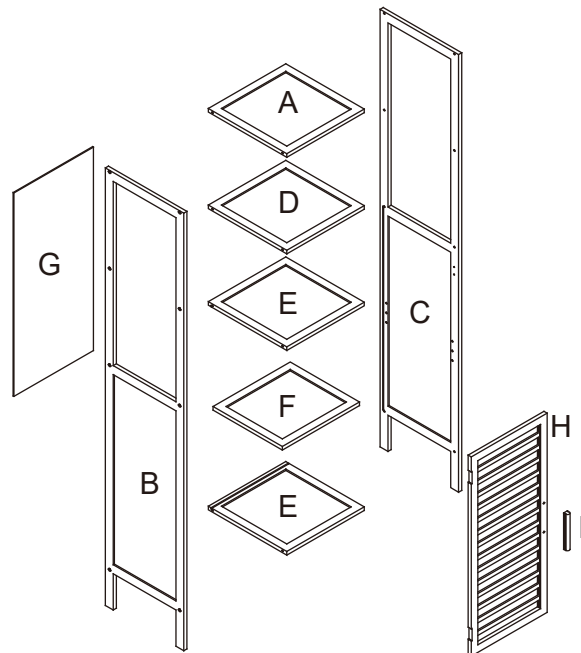

Do not tighten the screws fully during assembly.
Fully tighten screws after the final assembly steps

STEP 1

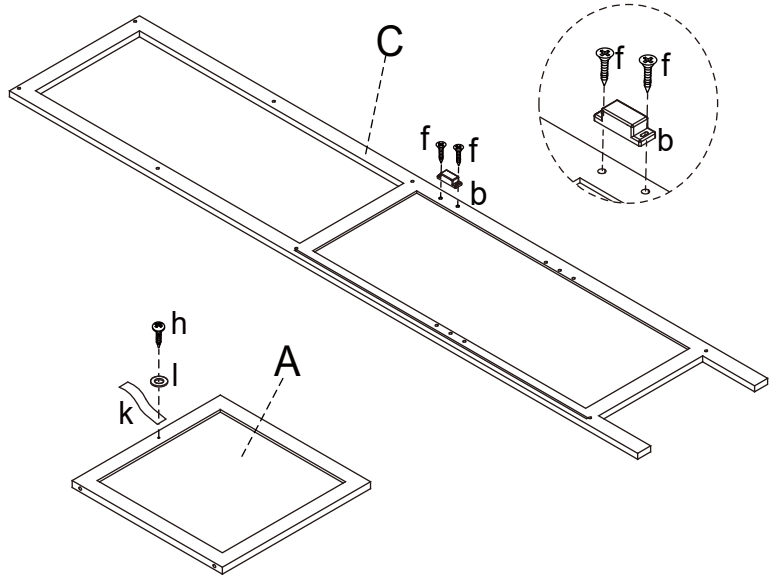

STEP 2

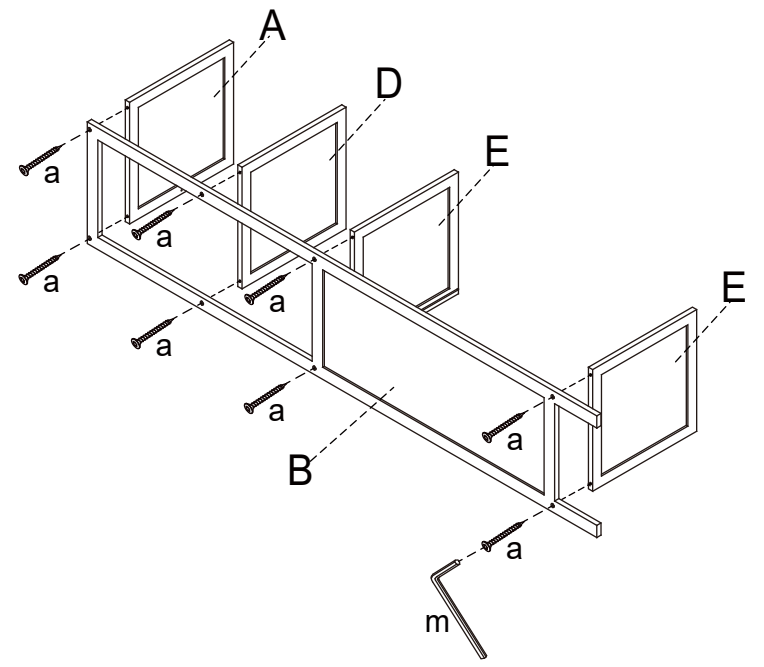

STEP 3

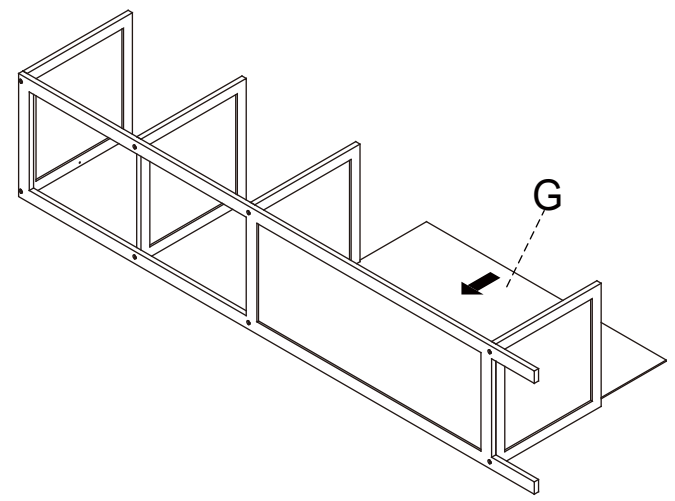

STEP 4

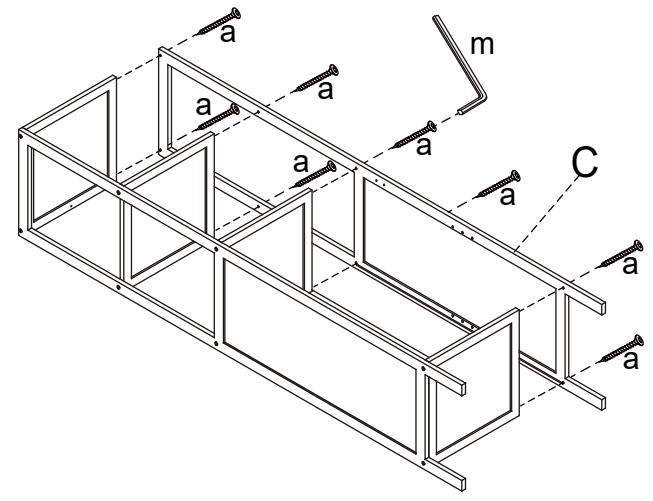

STEP 5

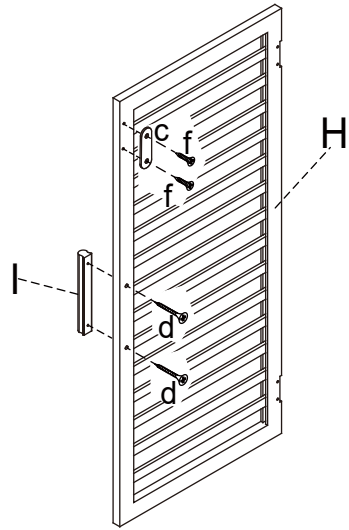

STEP 6

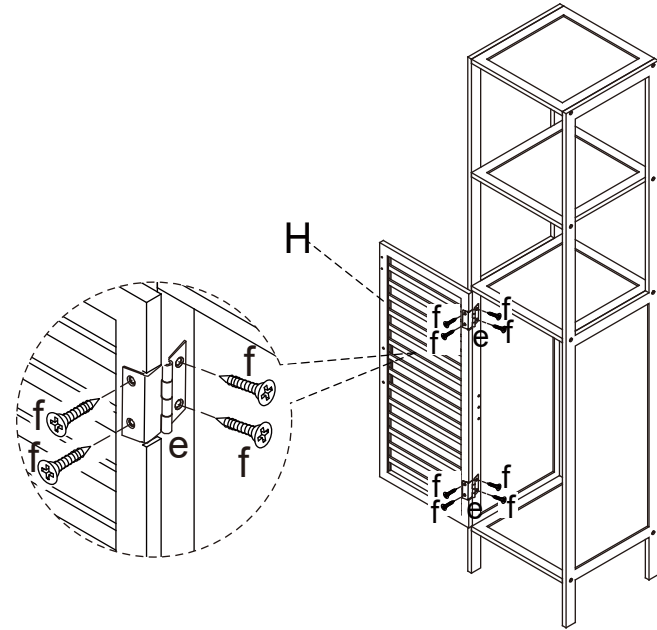

STEP 7



wall

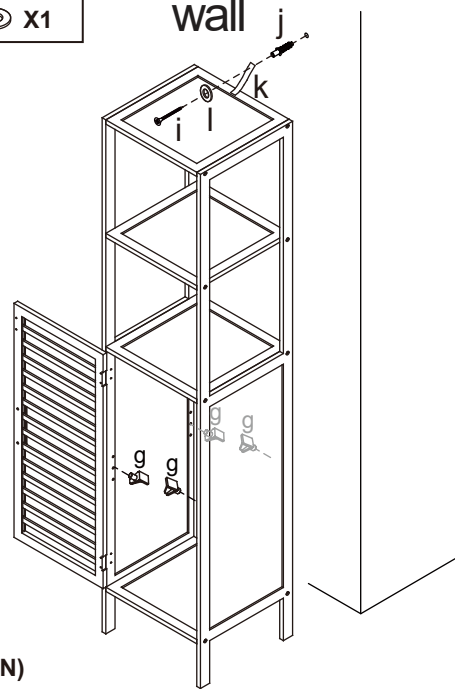

USER INSTRUCTION FOR WALL FIXINGS:
IT IS STRONGLY RECOMMENDED THAT THIS PRODUCT IS PERMANENTLY FIXED TO THE WALL. PLEASE SEEK PROFESSIONAL ADVICE IF YOU ARE IN DOUBT OF WHAT FIXING DEVICE TO USE. REGULARLY CHECK THAT WALL FIXINGS ARE SECURELY MAINTAINED. FOR YOUR SAFETY WHEN ATTACHING THE ANCHOR FIXINGS, PLEASE NOTE THE FOLLOWING: CHECK ANY ELECTRICAL WIRES OR PLUMBING INSIDE THE WALL BEFORE DRILLING ANY HOLES (IF YOU ARE UNSURE PLEASE SEEK PROFESSIONAL ADVICE FROM A QUALIFIED TRADESPERSON)

STEP 8

