

Metal Sand Digger Instruction Manual

Keycode 43032372

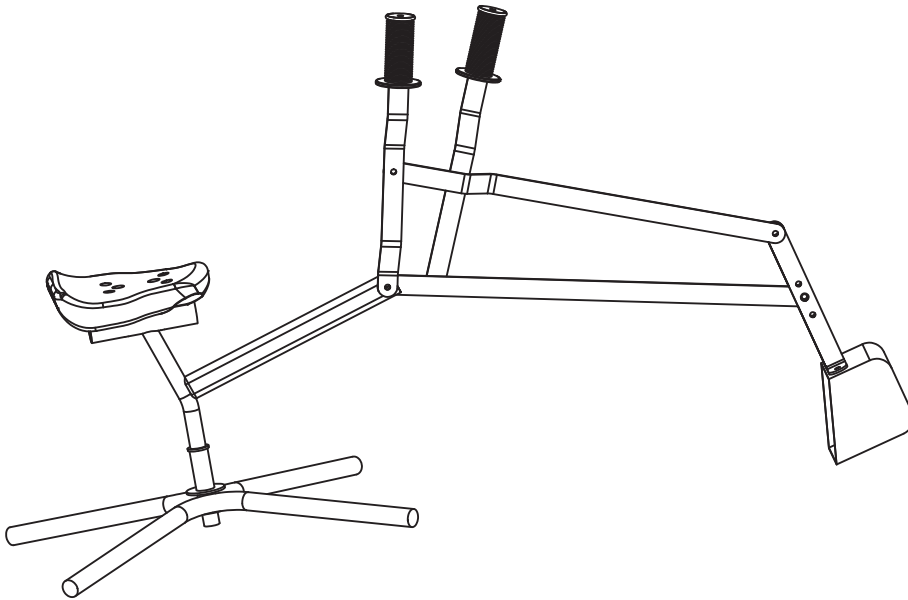

WARNING!



This must be assembled by an adult before use.

This product contains small parts and is not suitable for children under 36 months.

Small parts. Choking hazard.

Children must not use the equipment until properly installed. Adult Supervision is recommended.

Only for domestic use. For outdoor use.

Check all fastenings regularly and often. Failure to do this way result in the product malfunctioning, and causing injury.

Suitable for children 3+ years of age. Maximum user weight 35KGS.



The unit is designed to be used safely for 1 child only.

This toy is intended to be used to dig and move loose sand & dirt & clay soil. Digging rocks and gravel and ice or any other hard material may damage or break the digger.

Before operation, instruct your child and others in the area of operation to keep hands and feet away from moving parts of the digger to avoid pinching or other injury.

Storing in a dry location when not in use will help to extend the life of your Digger.

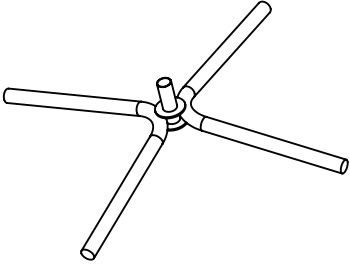
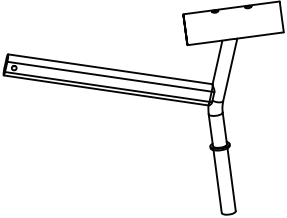
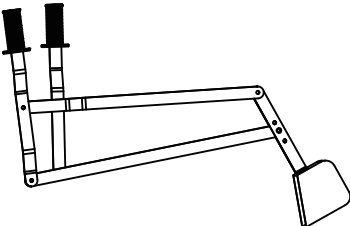
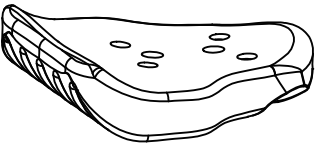
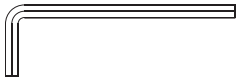
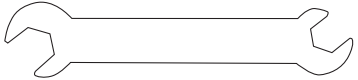
Periodic lubrication of the bolt joints with a basic lubricant will help extend the life span.

PART #	PART DESCRIPTION	QTY
1	 <p>Support base</p>	x1
2	 <p>Seat support tube</p>	x1
3	 <p>Handle tube</p>	x1
4	 <p>Seat</p>	x1
5	 <p>Hex key</p>	x2
6	 <p>Spanner</p>	x1
7	 <p>Screw set M8*58MM</p>	x2
8	 <p>Screw set M6*30MM</p>	x1

Step 1: Support base assembly

Push the button on the seat support tube and slide the seat tube into support base vertical tube until the button is stuck on the round metal plate on support base.

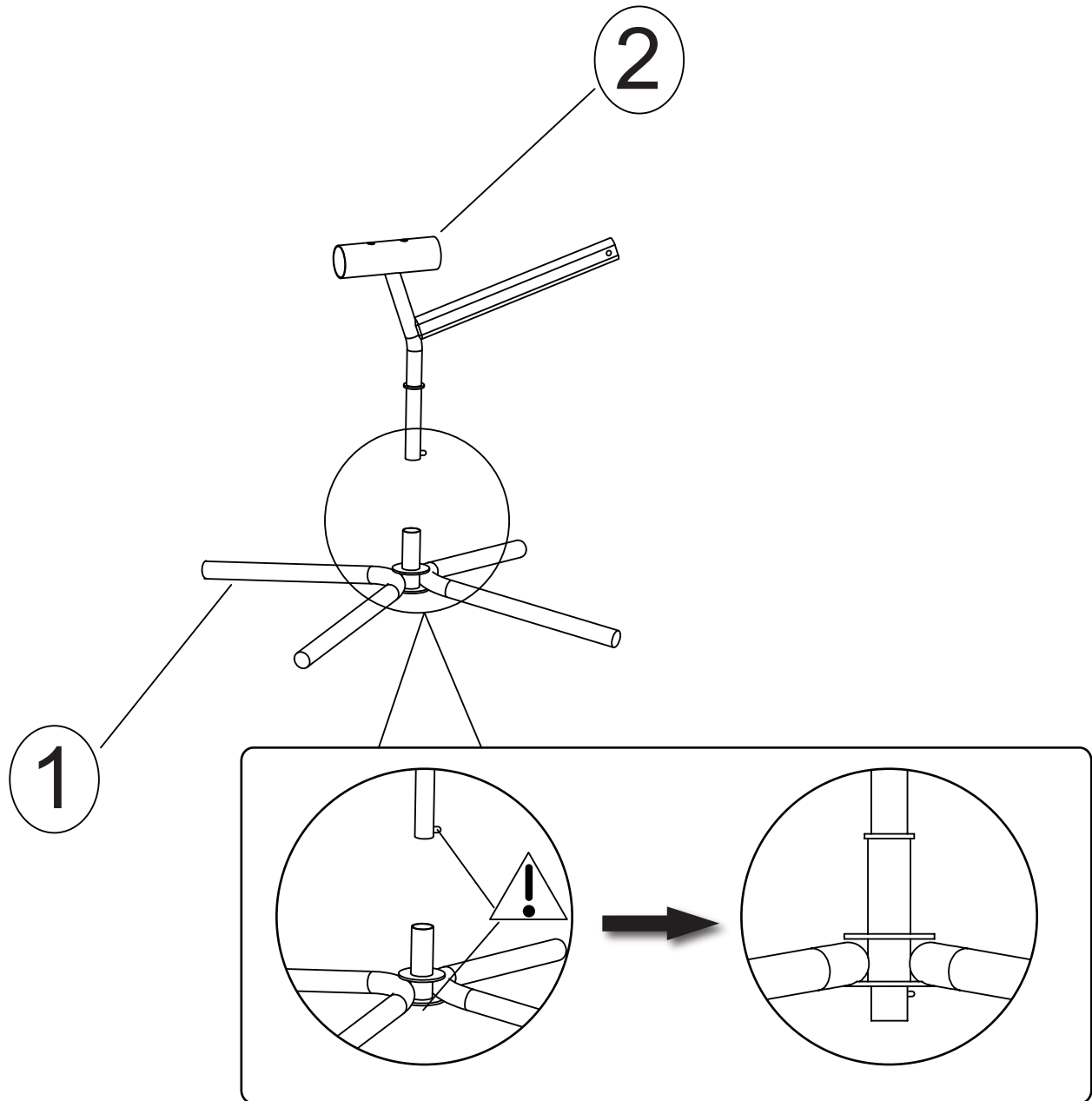

Step 2: Handle tube assembly

Put the seat tube in the middle of two handle tubes, fix the screw set (M6*30MM) through holes.

Please note big spacer should be put in between the seat support tube.

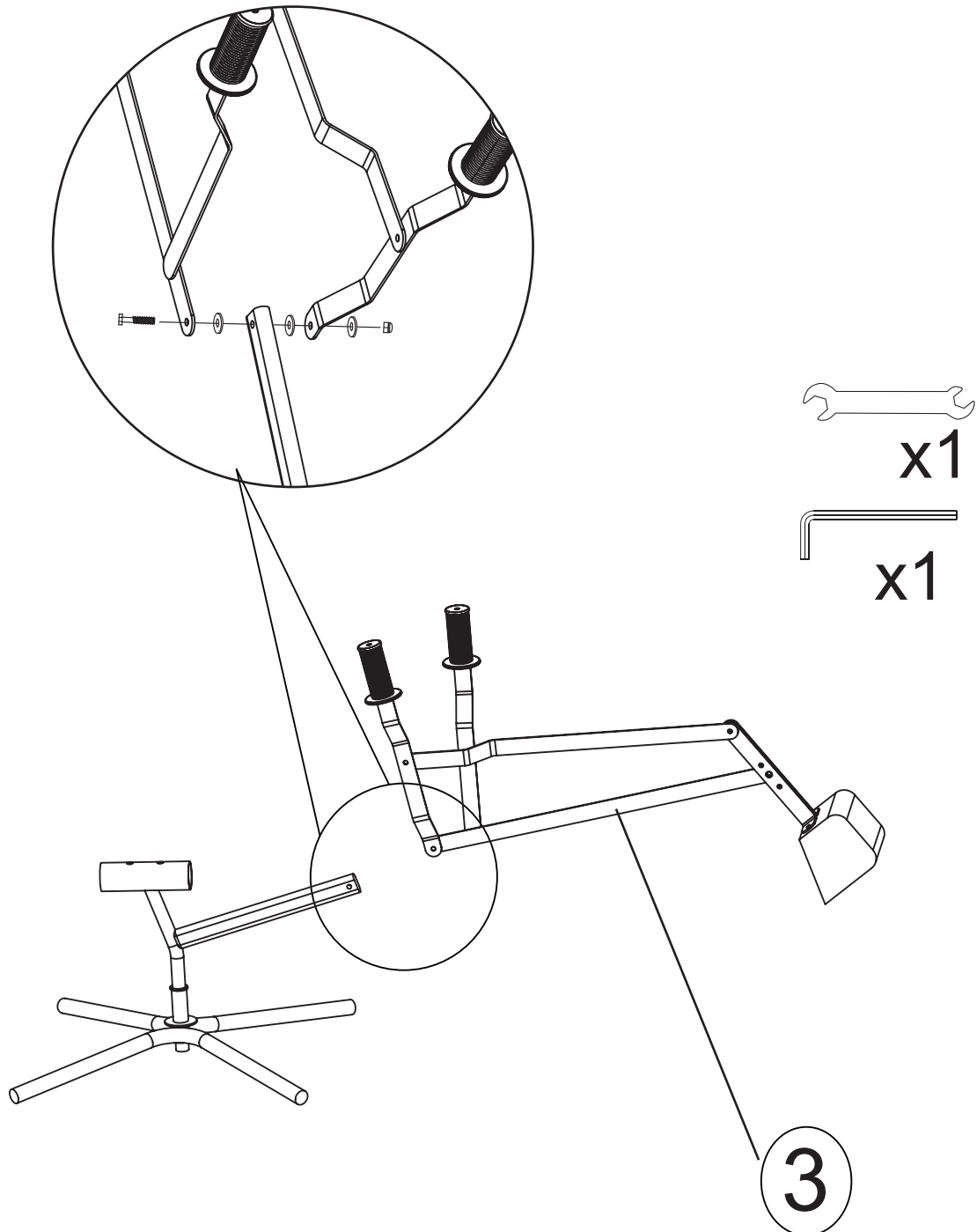

Step3: Seat assembly

Put the seat on the seat support tube ,
fix the seat on tube with screw set (M8*58MM).

