

# KICK SCOOTER INSTRUCTIONS

**Keycode: 43033386**

**WARNING!** Assembly by an adult.

**WARNING!** Not suitable for children younger than 5 years old, danger of falling.

**WARNING!** Protective equipment should be worn. Do not use scooter at night. Do not use on wet surfaces, uneven or unpaved road. Do not use on public roads. Not for children with a body mass of more than 50kg.

Remove the scooter and all the parts from the box. Set out all the parts and read the assembly instructions prior to use. Keep the packaging until assembly is complete.

## General instructions

- This scooter must be assembled by a responsible adult. Prior to use, make sure that the scooter has been assembled properly. Remove all the parts which are not necessary for play before giving the scooter to your child. Due to the skill it requires, the scooter must be used with care in order to avoid falls or collisions likely to injure the user or others.
- To be used with suitable protective equipment, including a helmet, shoes, elbow, wrist and knee protectors. Teach the child how to use it safely and responsibly.
- The scooter is not a toy for children under the age of 5 years.

## Riding Instructions

- a) The scooter can be dangerous and can lead to a traffic accident when used on public highways. Don't use on the public roads.
- b) It is best used on a flat, clean surface, free of gravel and grease.
- c) Avoid bumps and drainage grates that may cause an accident.
- d) The scooter does not include any headlights or lights. It is therefore not suited for use at night or during periods when visibility is limited.
- e) Always use under adult supervision.
- f) Do not allow more than one child to ride the scooter at the same time.

## Before and after use

- Check all screws and fittings are secure before giving to a child.
- Ensure all locking devices are engaged. Ensure there are no broken components.
- Spin each wheel to make sure the wheel rotates smoothly indicating that the bearings are undamaged.

## Use

- Standing on the scooter, one hand on each handle, push with one of your feet to move forward. Proceed with caution at the start.
- Braking: a brake is located at the rear, when necessary, press down on it to slow down. Press down gradually in order to prevent skidding or loss of stability. The metal or aluminium brake may heat up after multiple uses. Avoid touching it during and after use.
- Shoes are mandatory and we strongly advise you wearing pants and long sleeve shirts to avoid injury.

## Assembly Instructions:

Step 1: Slide clamp over ribbed section above headset on deck assembly.

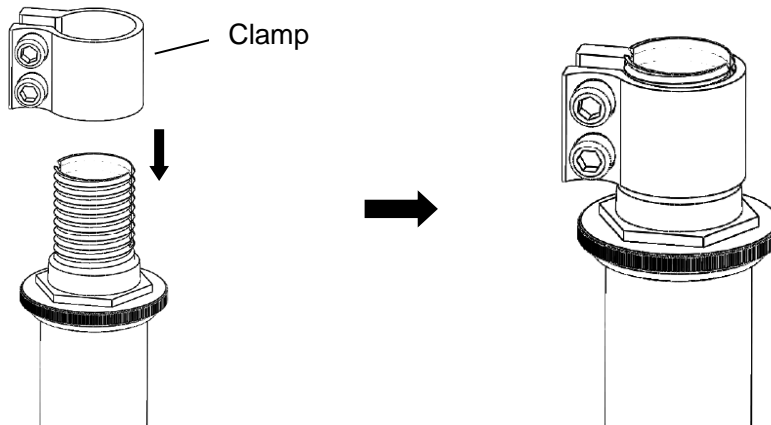

Step 2: Align small metal tab on bottom handle bar assembly with groove on inside of headset on deck assembly.

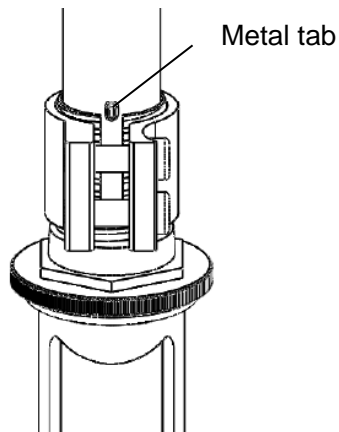

Step 3: Slide handle bars into headset.

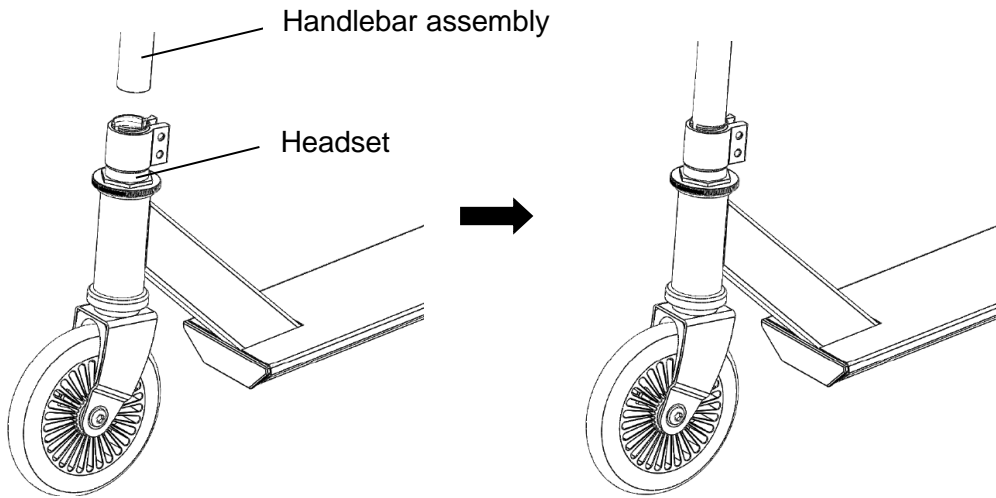

Step 4: Tighten bolts alternately using the allen key provided until secure.

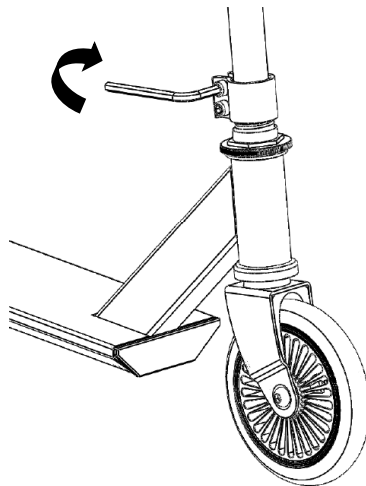

## Care Instructions

**A. Wheel bearings:** Avoid going through water, oil or sand as this can damage wheel bearings.

To look after the wheel bearings, systematically check that the wheels turn properly by turning the scooter upside-down and using your hand to spin the wheels. If the wheels do not spin they must then be removed to check their condition. First unscrew the wheel axle, remove the axle and detach the wheel, then carefully push the two wheel bearings out of their housing. If they are chipped or dented, new ones should be bought. If there is no visible damage, they must then be oiled. To do this, remove all traces of grease, mud or dust with a kitchen towel or cloth, and re-oil them with a grease spray or by leaving them to soak overnight in oil [turn them several times in the oil first]. Remove reassemble

the wheel bearings and axles, followed by the wheel, onto the scooter. Proceed in the same manner for the other wheel.

**B. Wheels:** The wheels wear down with time and can be pierced if overly used on rough surfaces. The back wheel on which the brake is applied is particularly affected after several hours of braking. In the interests of safety, they should be checked regularly and changed if necessary.

**C. Modifications:** The original product must by no means be modified except for the maintenance-related changes mentioned in these instructions.

**D. Nuts and axles:** These should also be checked regularly. They can become loose after a while in which case they should be tightened. They can become worn and not tightened properly, in which case they should be replaced.

**MADE IN CHINA**

FOR AU / NZ: IMPORTED FOR KMART  
STORES IN AUSTRALIA AND NEW ZEALAND.