

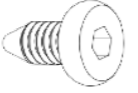







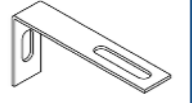
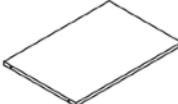

Assembly Instruction

Please read the instruction carefully. Remove all parts from the carton. Be sure you have all parts before you start assembling. Place all parts on the clean and flat soft surface, such as carpet or rug to prevent from being scratched.

WARNING:

Do not stand on the shelf. Do not use the item as a step ladder. Do not use the shelf unless all screws are firmly secured. Adult assembly required. Failure to follow these warnings could result in serious injury. For indoor use only. Maximum loading weight per shelf: 10KG.

Parts & Hardware List					
	A	2 PCS		G	4 PCS
	B	2 PCS		H	1 PCS
	C	2 PCS		I	1 PCS
	D	3 PCS		J	1 PCS
	E	12 PCS		K	1 PCS
	F	8 PCS		L	1 PCS

Step 1.

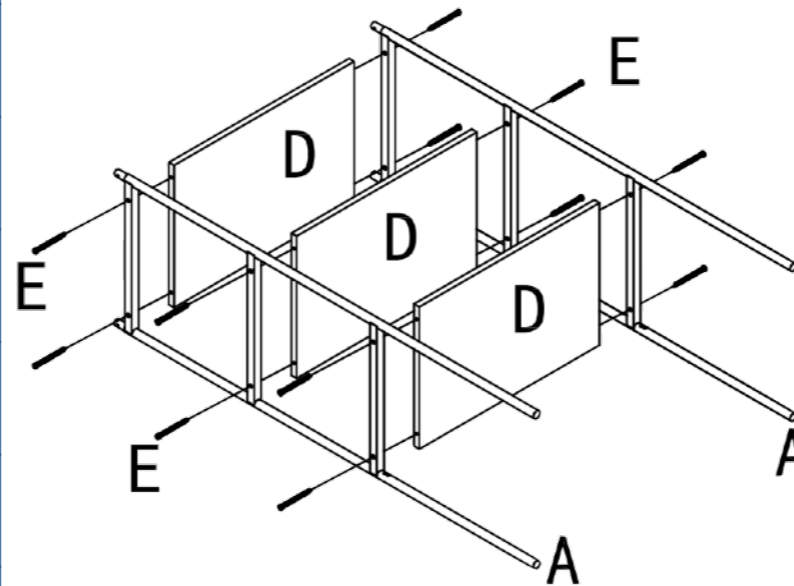

Step 2.

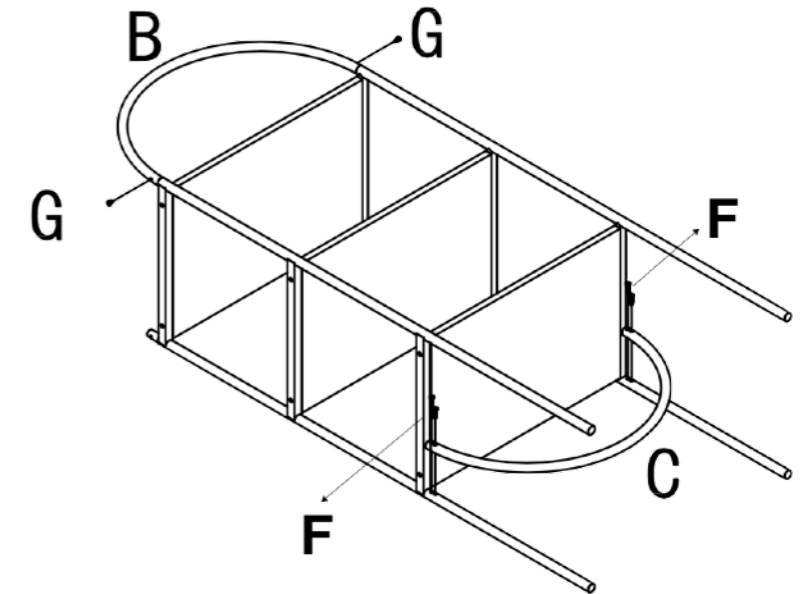

Step 3.

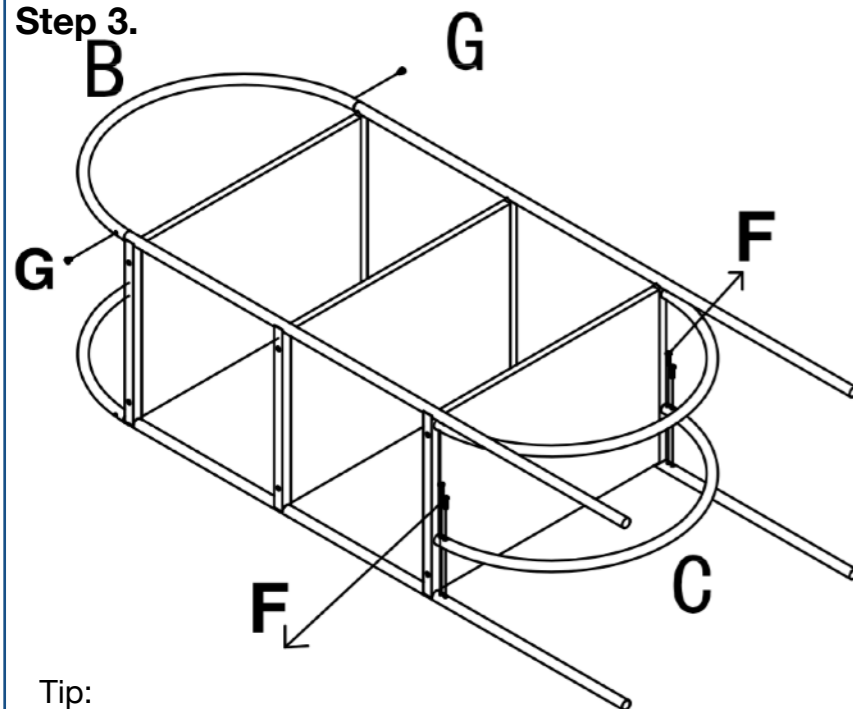

Tip:
Flip the unit upside down before moving to next step.

Step 4.

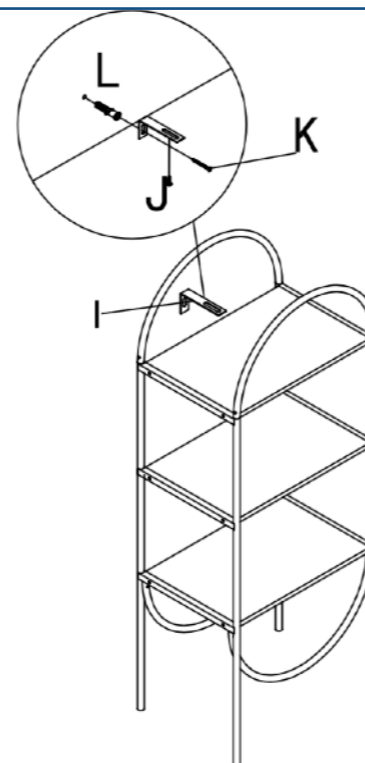

Toppling Hazard Warning

- It is strongly recommended that this product is permanently fixed to the wall.
- Please seek professional advice if you are in doubt of what fixing device to use.
- Regularly check that anchors are securely maintained.
- Stability of tall items may be affected by thick pile carpet or uneven floors.

Caution:

For your safety when attaching the anchor fixings, please check any electrical wires or plumbing inside the wall before drilling any holes (if you are unsure please seek professional advice from a qualified tradesperson)