

Climbing Frame

Operating instructions

includes:

- › Steel tubes
- › Screw set
- › Anchors

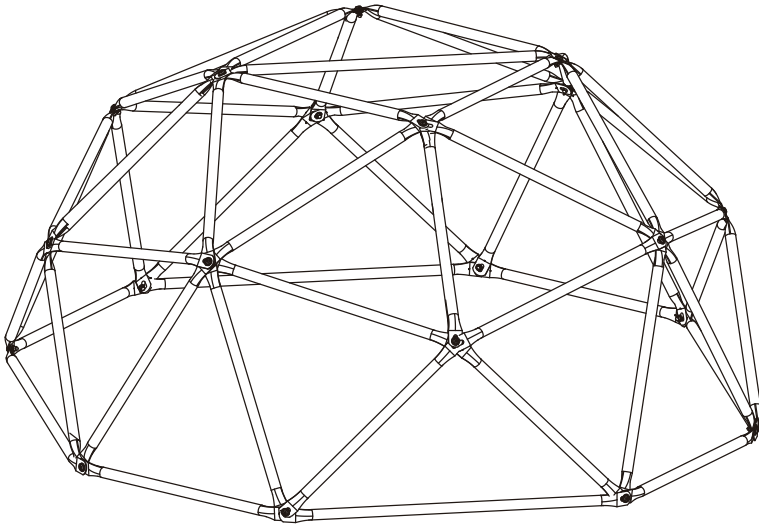

CLIMBING FRAME SAFETY INSTRUCTIONS

WARNING! WARNING! WARNING! WARNING! WARNING! WARNING! WARNING!

YOUR CHILD'S SAFETY DEPENDS ON YOU!!!

Observing the following statements and warning reduces the likelihood of serious or fatal injury.

1. Provide on-site adult supervision for children 3+ years at all times.
2. Be certain that all anchoring devices(including concrete)are placed below the level of the playing surface or below ground level to prevent tripping.
3. NEVER allow children to stand on the climbing frame DO NOT allow children to lean to the side when riding on other rides, structural members or collide with other playmates.
4. Dress children appropriately while on and around this equipment. DO NOT allow children to wear ponchos, scarves, jewellery, loose shoes, jackets or clothing with loose strings, and/or clothing that might be potentially hazardous while using this equipment.
5. DO NOT let children use equipment in any manner other than intended.
6. DO anchor climbing frame DO NOT install over concrete, asphalt, gravel or any hard surface which may cause injury should a fall occur.
7. DO NOT let children use equipment until properly assembled and anchored. Place climbing frame on LEVEL GROUND not less than 8.2 feet(2.5m) from any structures or obstacles such as fences, overhanging branches, laundry or electrical lines garages, sheds or houses.
8. Instruct children to avoid swinging empty play stations. Stations may strike other children or come back and strike you .
9. Instruct children not to walk closely in front of , behind or between moving plays. Instruct children to keep a safe distance away to avoid being struck by items in play.
10. DO NOT allow children to jump from moving play items.
11. DO NOT allow children to climb or play on equipment while wet. (Slips or falls may occur.)
12. DO NOT leave bolts threads uncovered TIGHTEN all hex nuts securely
13. DO NOT attach items to the playground equipment that are not specifically designed for use with the equipment, such as, but not limited to, jump ropes, clothesline, pet leashes, cables, and chain as they may cause strangulation hazard.
14. Please retain the instruction manual for future reference and review each season.

WARNING:BE SURE TO FOLLOW ALL INSTRUCTIONS ABOVE

SAFETY INSTRUCTIONS

WARNING!

Adult assembly required
Adult supervision recommended at all times
Maximum user weight of 50kg
Only for domestic use
Outdoor use only
Not suitable for children under 36 months – fall hazard
Retain instruction manual for future use

Place on a level surface at least 2.5 m from any structure or obstruction
Must not be installed over concrete, asphalt or any other hard surface
It is advised that on a regular basis (i.e. at the beginning of the season and monthly thereafter) all main parts/ fixings are checked as secure, well oiled (if metallic), have no sharp points/edges and are intact. Replace, oil and/or tighten when necessary. Failure to do so may result in an injury or hazard.
Any part such as tube, screw, spacer, nut, etc must be regularly examined for evidence of deterioration. Replace any attachments if there are signs of deterioration. Failure to do so may result in an injury or hazard.
Do not allow children under 3 years to use it.

WARNING!

Unexpected movement (i.e.: tipping, lifting and overturning) of the swing set may result in serious injury or death. The climbing frame must be securely anchored before use

WARNING!

The owner should disassemble and dispose of the playground equipment in such a way that no unreasonable hazards will exist at the time the playground equipment is discarded.

Proper Play Conditions:

- Always use the product in a well-lit area. Do not use without lighting during dawn, dusk or in complete darkness!
- Maintain clear space on all sides of the product. Such objects include walls, fences, tree limbs/trunks, electrical power wiring, rocks, sprinkler heads or other recreational objects (i.e. swing sets, swimming pools).
- The product must not be used in windy and rainy conditions as wind can cause unexpected movement and rain can cause expected slippery surfaces on the product.

CONTACT US

Thank you for purchasing from Kmart.
Please contact our customer service centre

JCA Collective
Email: service@jcacollective.com
Phone Number: +61 423 259 751
Office Hours: Monday to Friday 9am to 5pm

SAFETY NOTES:

- Adult assembly required.
- Adult supervision required when product in use.
- For domestic use only.
- For outdoor use only.
- Children must understand how to use the product safely.
- DO NOT allow children to play around product when in use.
- DO NOT allow more than 1 child to use this product at a time.
- Limit the time of continuous usage (make regular stops).

MAINTENANCE INSTRUCTIONS:

- Checking fixings regularly. Injury may be a result if you fail to do so .
- Checking the nuts and bolts on a regular basis for tightness, sharp edges or deterioration.
Tighten or replace when required.
- Check paintwork regularly and if needed touch up with enamel
- Check all nuts and bolts for tightness and tighten when required.
- Oil all metallic moving parts.
- Check all coverings and bolts for sharp edges and replace when required.
- Check all parts such as tubes, screw, nut, spacer, etc for evidence of deterioration;replace when required in accordance with the manufacturer's instructions. Failure to do so may result in injury or hazard.
- Sand rusted areas and tubular members and repaint using a non-lead based paint when required.
- Retain the instructions for assembly, maintenance and safe use for future reference.

Specifications

This climbing frame is designed for use by children ages 3+ years old with a maximum weight of 50kg. The maximum fall height of this climbing frame is 0.9m.

This product is designed for normal residential use only. This product is not designed for use in day care, nurseries, or other public places. This product is to be assembled by adults only in the manner described within this instruction manual.

This product must be anchored. Anchors are included with this climbing frame.

Assembly

Only adults should assemble or disassemble the climbing frame. For safety reasons and ease of assembly, it is recommended that two adults assemble the climbing frame.

Points to remember when locating and placing the climbing frame.







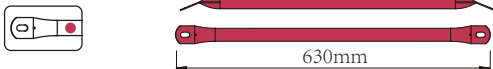
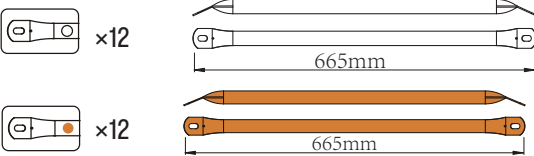
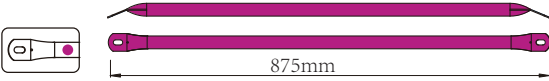
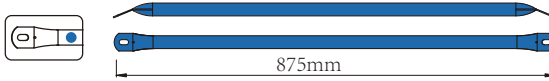

- Place your climbing frame on level ground a MINIMUM of eight point two (8.2) feet (2.5m) from any structure or obstruction such as a fence, garage, house, over hanging branches, laundry lines, or electrical wires.
- Do not install home playground equipment over concrete, asphalt, packed earth, grass, carpet, or any other hard surface. A fall on to a hard surface can result in serious injury to the equipment user.
- Do not place your climbing frame underneath electrical lines. If you must, ensure that there is a minimum over head clearance of eight point two (8.2) feet (2.5m).
- Do not make any modifications to the product, it may result in an injury or hazard. Do not over tighten nuts and screws as this may cause them to shear and potentially cause structural failure.

Location and Placement of Your Climbing Frame

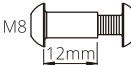
Proper placement and maintenance of protective surfacing is essential.

Be sure to:

- Extend surfacing at least 8.2 feet (2.5 m) from the equipment in all directions. Climbing frame must be placed a minimum of 8.2 feet (2.5 m) from any structure or obstruction such as a fence, garage, house, overhanging branches, laundry lines, or electrical wires.
- Do not place your Climbing frame underneath electrical lines. If you must, ensure that there is a minimum overhead clearance of 8.2 feet (2.5 m).
- Do not install Climbing frame over concrete, asphalt, packed earth, grass, carpet, or any other hard surface. A fall on to a hard surface can result in serious injury to the equipment user.
- For safe playing Climbing frame, extend protective surfacing 12 feet (3.66m) in front of and behind the point of suspension of the swing.

NO.	PART	DESCRIPTION	QTY
A		Climbing tube A	20
B		Climbing tube B	12+12
C		Climbing tube C	1
D		Climbing tube D	4
E		Screw set M8*32mm	12
F		Screw set M8*12mm	8
G		Plastic spacer	12
H		Washer	40
I		Spring washer	20
J		Plastic tie	24
K		Anchor	4
L		Hex key	2

Step 1: Assemble 3pcs of Tube B (with white sticker) and 3pcs of tube B (with orange sticker) plus one plastic spacer (G) by screw set as figure (1) shows. Please **DO NOT** assemble the screws tight at this step.

Repeat this step for 4 times to finish assembly in four circles in figure (2).

Figure 1

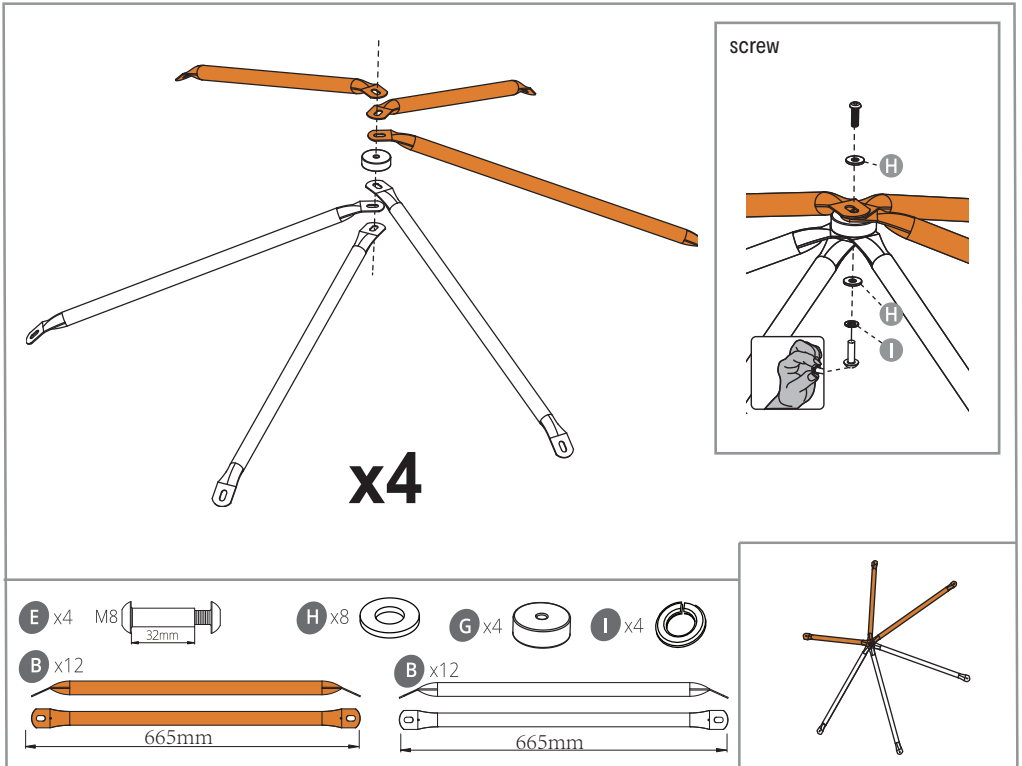
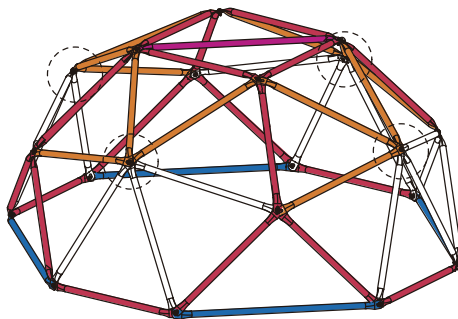

Figure 2



Step 2: Assemble 2 pcs of Tube with A sticker and 1 pc of tube with D sticker on the 1 pc tube B (with white sticker) finished in step 1 by screw set as figure (3) shows. Assemble 1pc of tube with A sticker and 1pc of tube B (with white sticker) with plastic tie. Please **DO NOT** assemble the screws tight at this step.

Repeat this step for 4 times to finish assembly in four circles in figure (4).

Figure 3

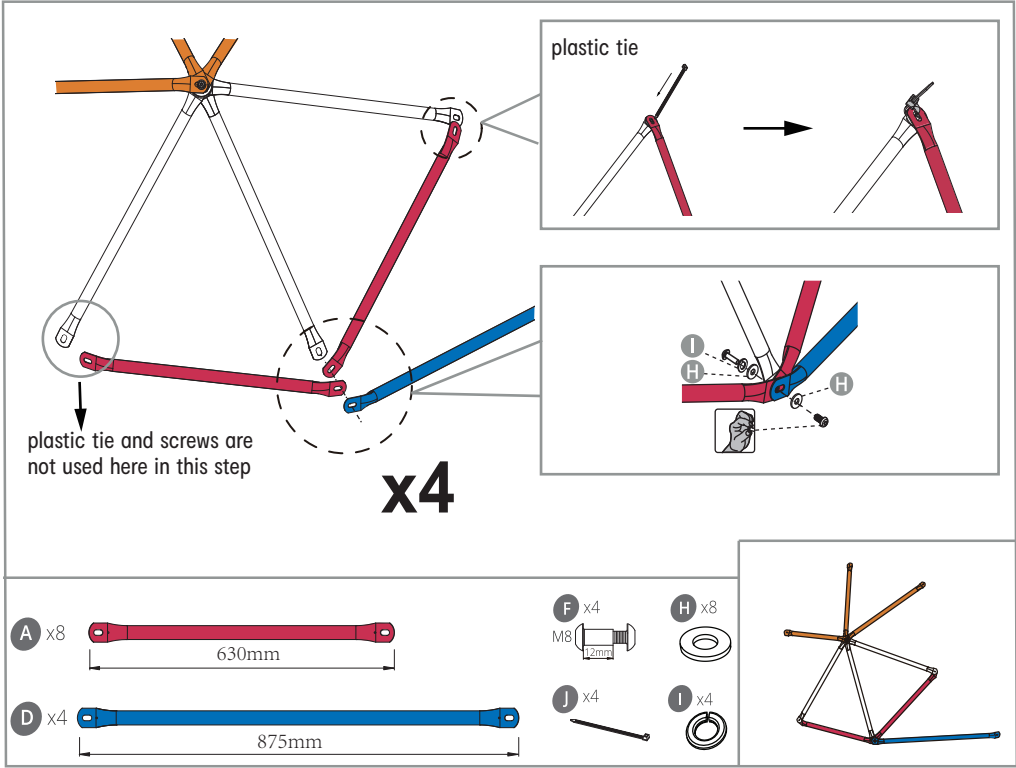
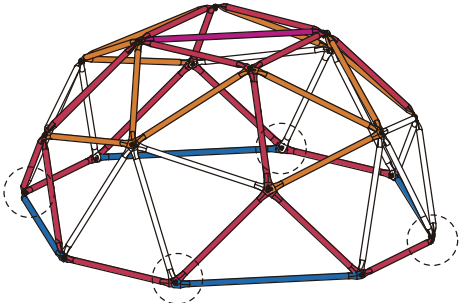

Figure 4



Step 3: Assemble 1pc of Tube with A sticker and structure finished in step 2 by plastic tie as figure (5) shows.

Repeat this step for 4 times to finish assembly in four circles in figure (6).

Figure 5

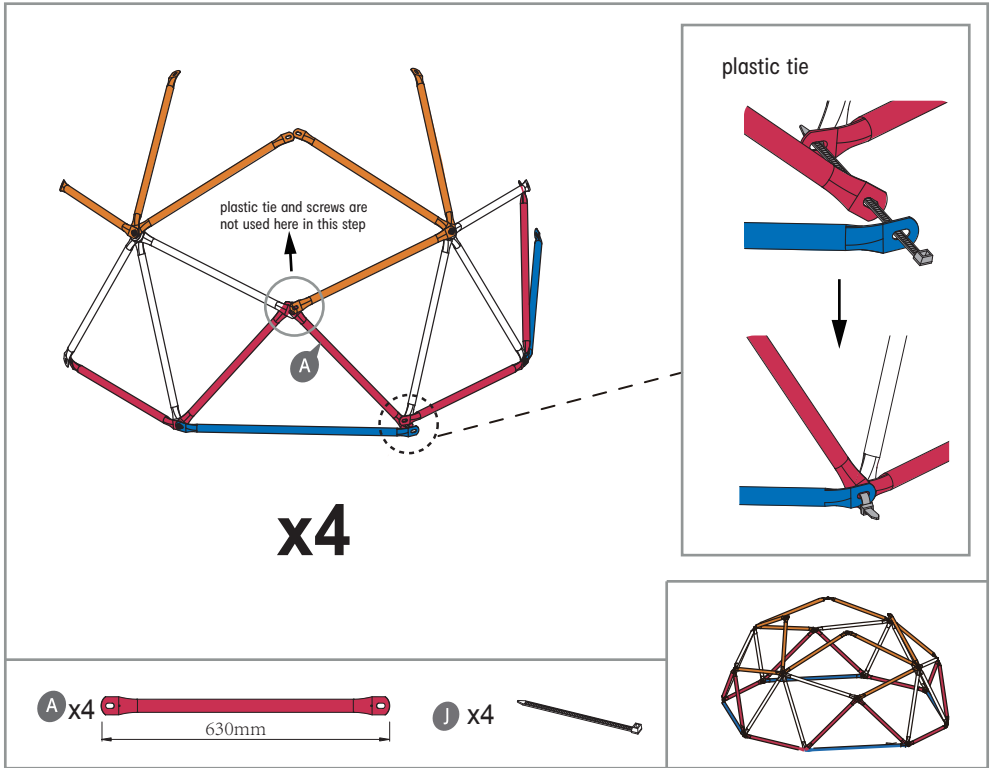
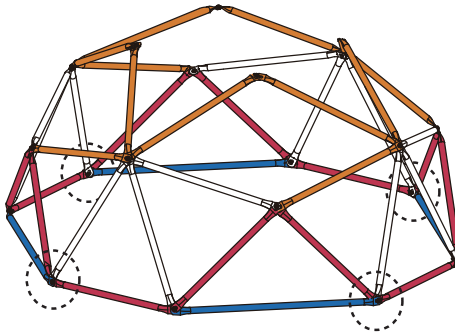

Figure 6



Step 4: Remove the plastic tie assembled in step 2, assemble one end of 1pc Tube with A sticker with structure finished in previous step plus plastic spacer by plastic tie as figure (7) shows.

Assemble another end of tube with A sticker mentioned above with structure finished in previous step with plastic tie.

Figure 7

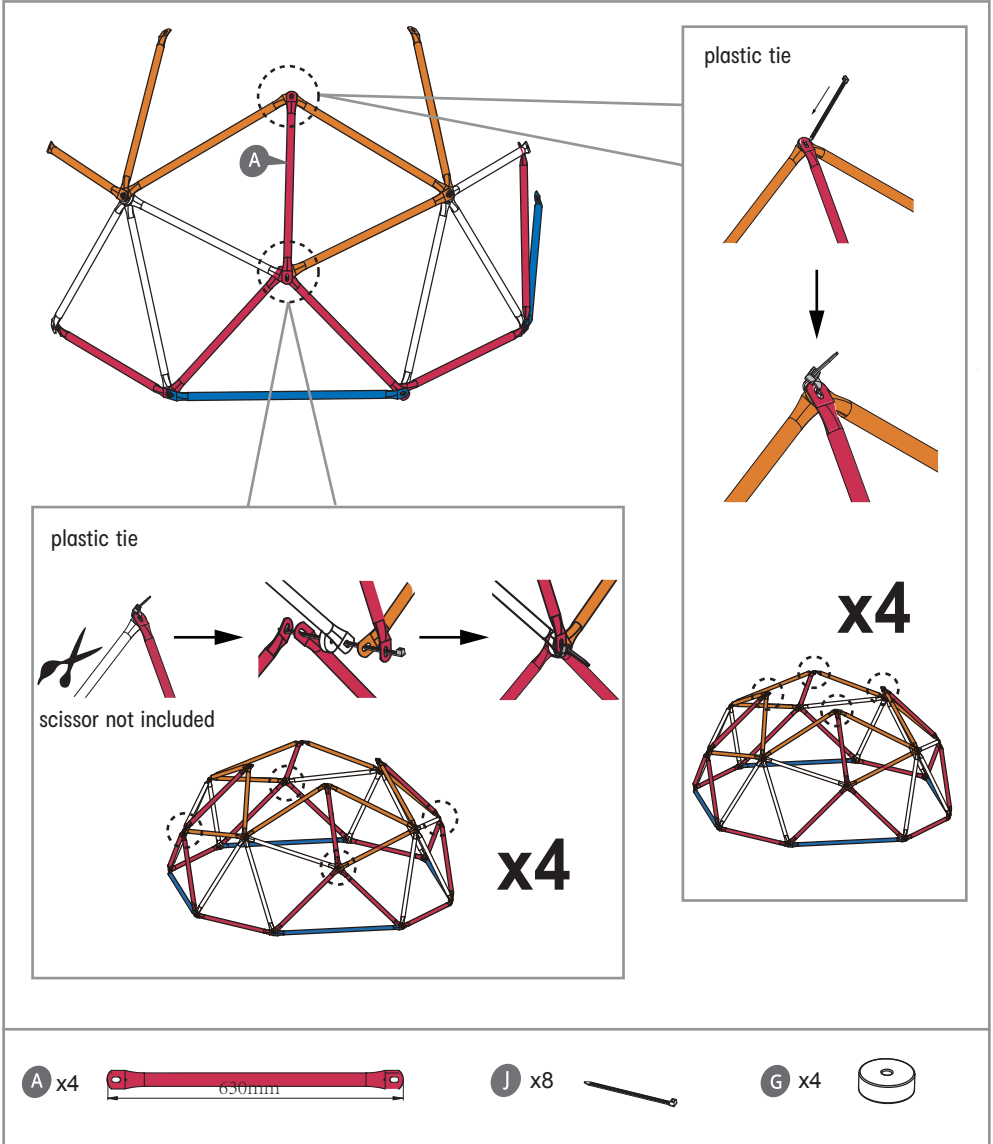

Step 5: Remove the plastic tie assembled in step 4, assemble 1pc of Tube with C sticker and 2pcs of tube with A sticker with structure finished in previous step plus plastic spacer by plastic tie as figure (8) shows. Repeat this step for twice.

Assemble 4 pcs of tube with A sticker mentioned above with structure finished in previous step plus plastic spacer by plastic tie as figure (9) shows. Repeat this step for twice.

Figure 8

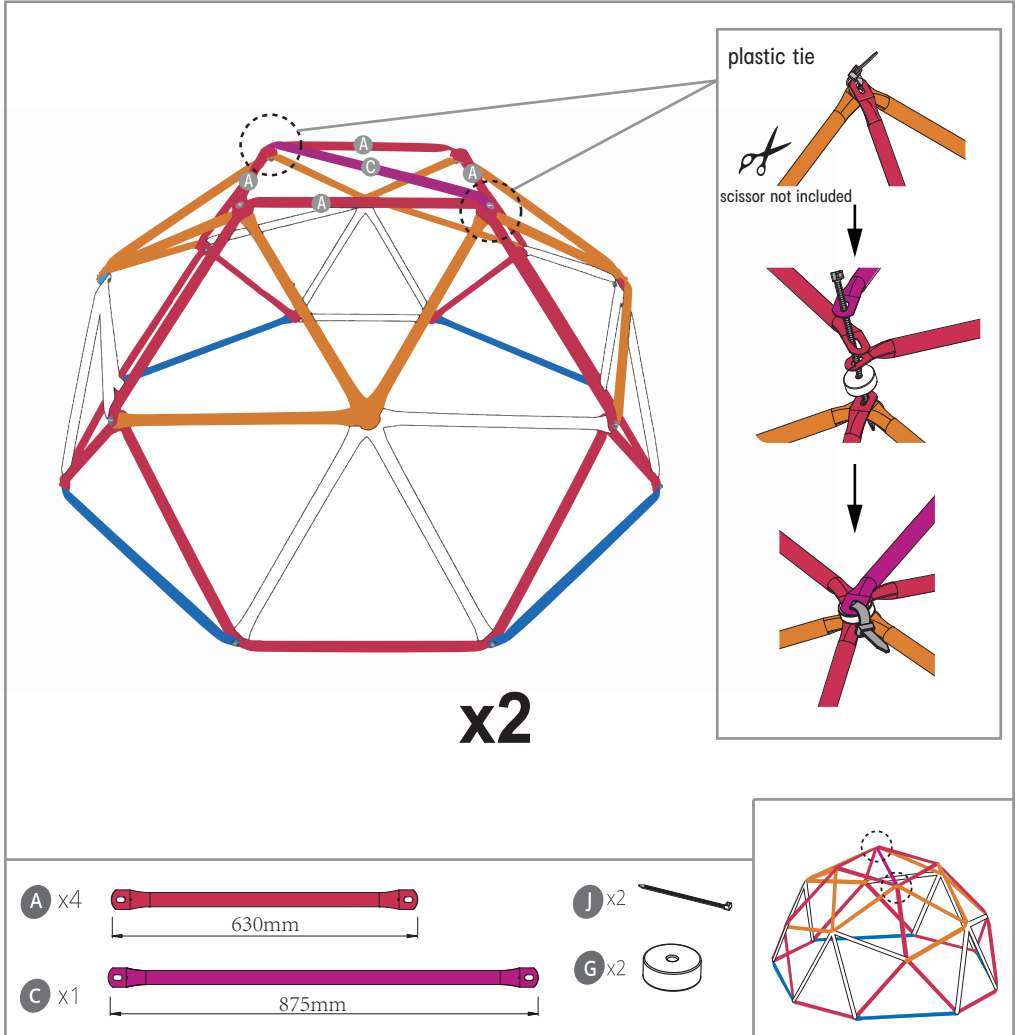
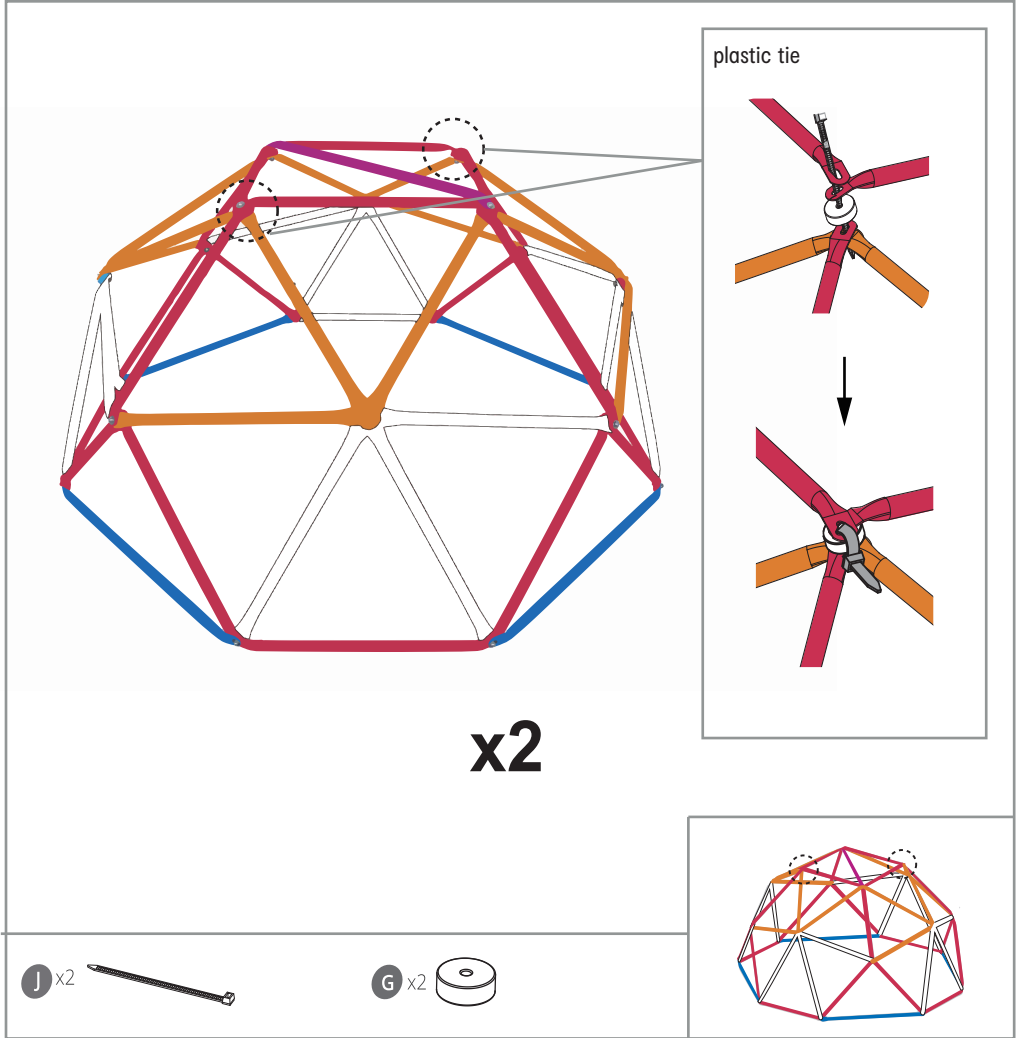

Figure 9



Step 6: Assemble all screws in the plastic tie area and then cut off the plastic ties as figure (10) (11) (12) shows

Please DO NOT assemble the screws tight at these steps.

Figure 10

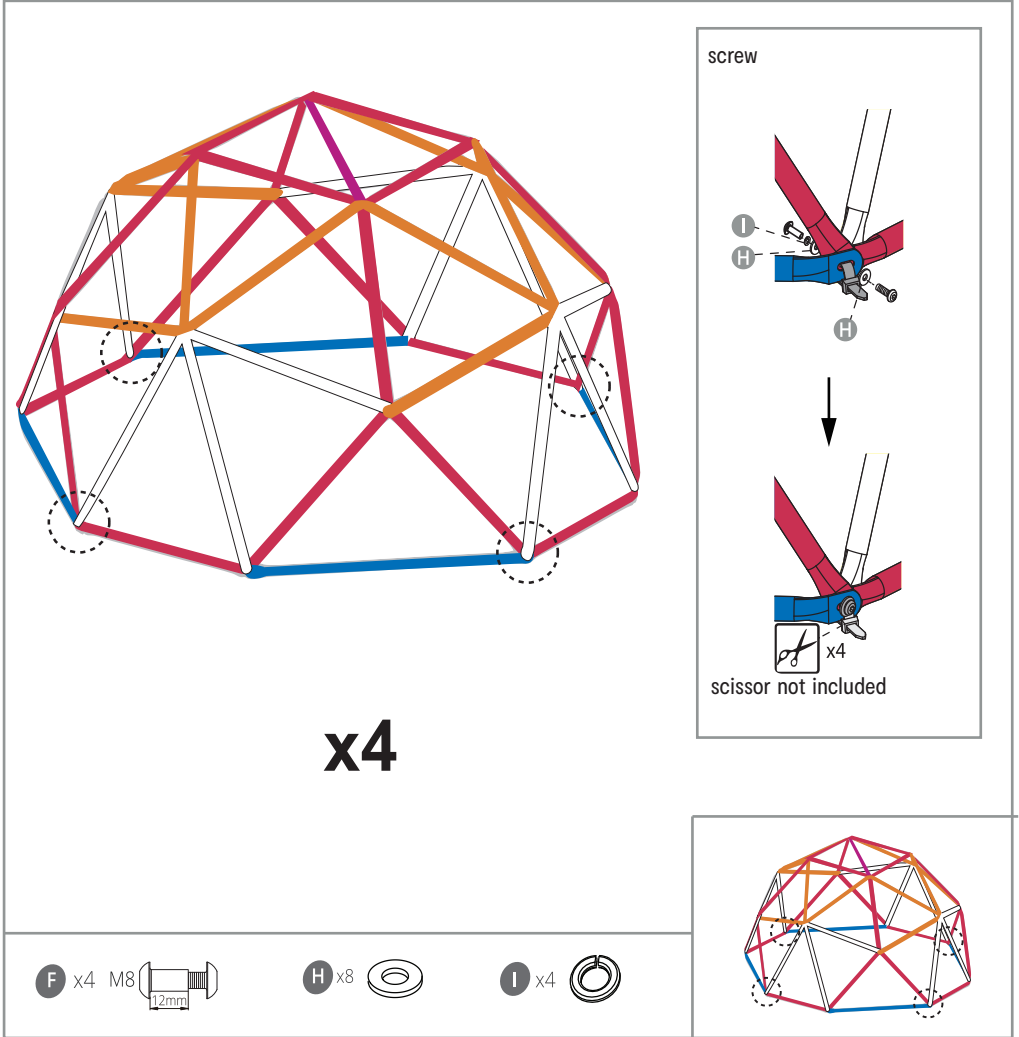

Figure 11

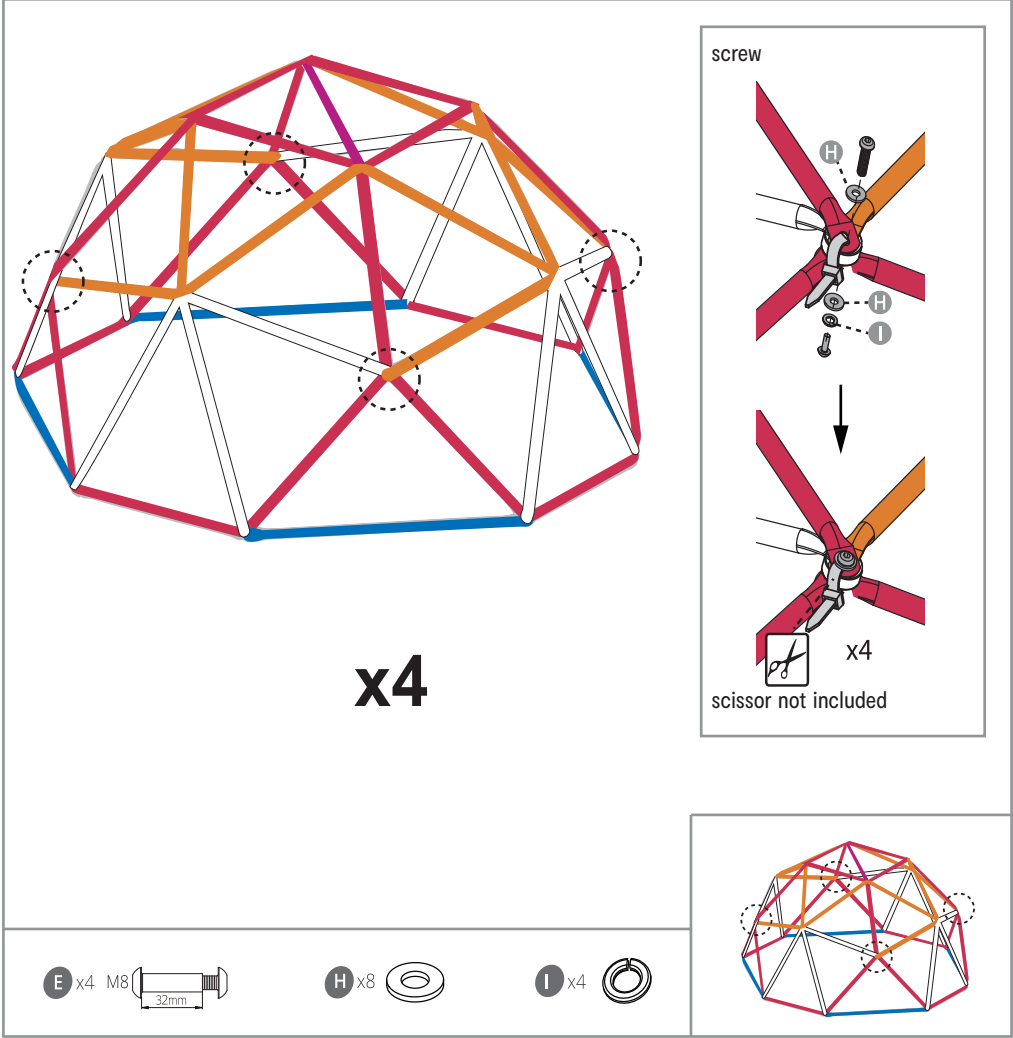
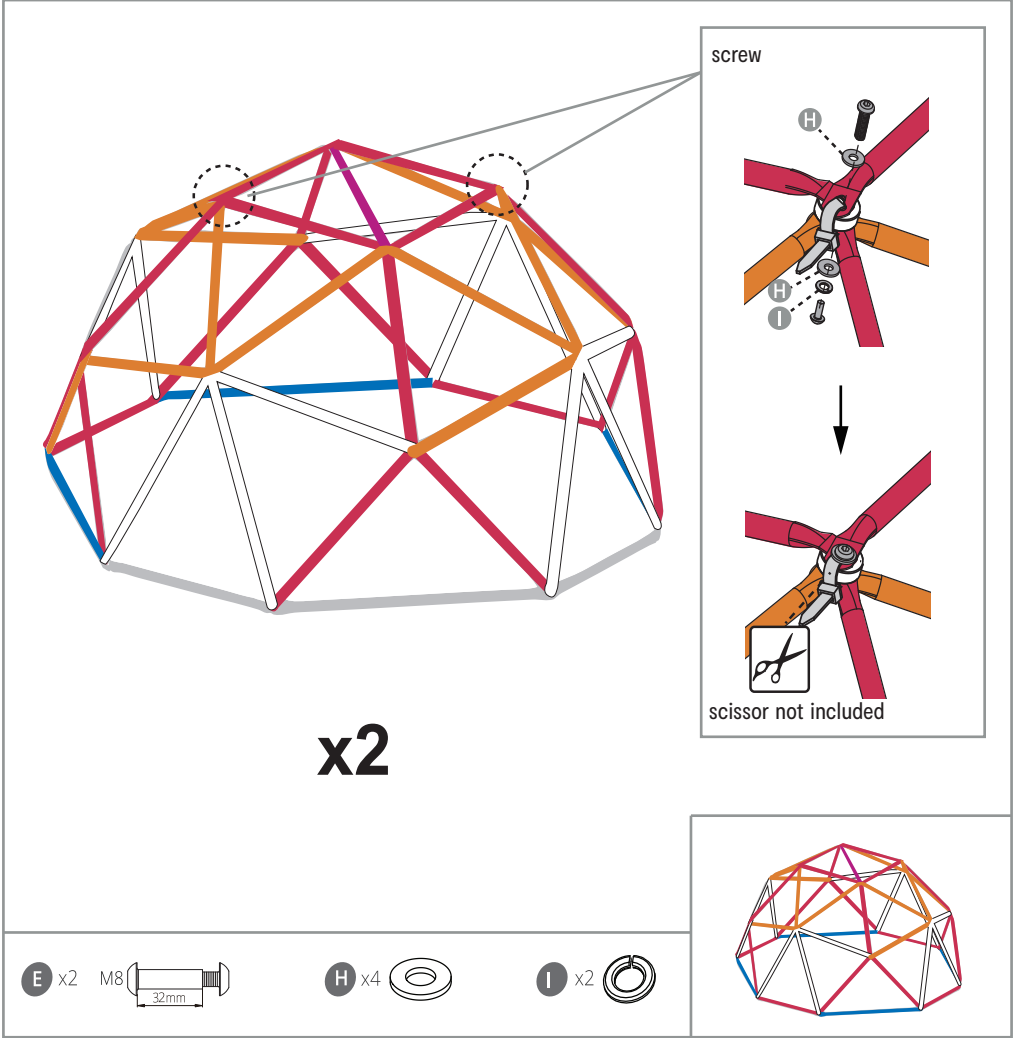
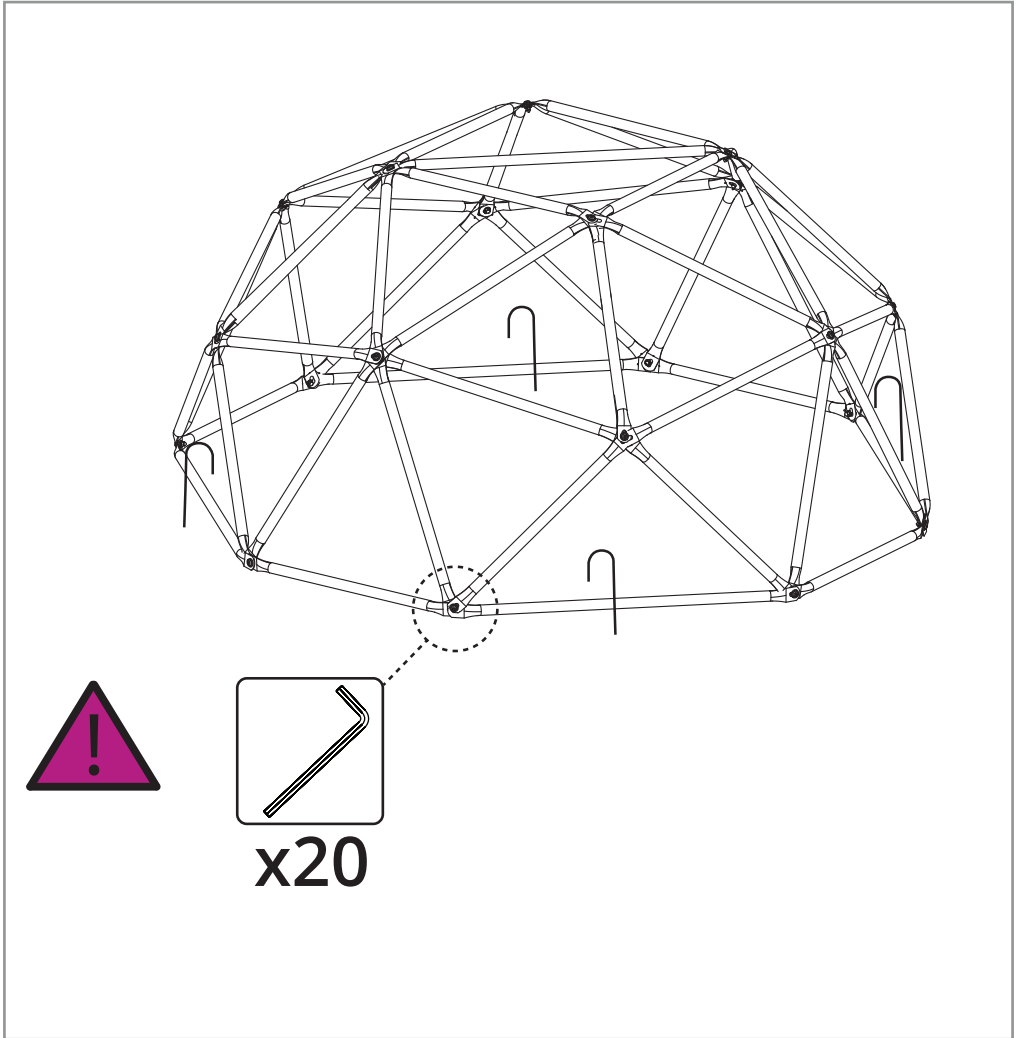

Figure 12



Step 7: Assemble all screws tight. Then assemble the anchors as figure (13) shows

Figure 13



Information on Playground Surfacing Materials

Select Protective Surfacing

One of the most important things you can do to reduce the likelihood of serious head injuries is to install shock-absorbing protective surfacing under and around your play equipment. The protective surfacing should be applied to a depth that is suitable for the equipment height in accordance with ASTM Specification F1292. There are different types of surfacing to choose from; whichever product you select, follow these guidelines:

Loose-Fill Materials:

Maintain a minimum depth of 9 inches of loose-fill materials such as wood mulch/chips, engineered wood fibre (EWF), or shredded/recycled rubber mulch for equipment up to 8 feet high; and 9 inches of sand or pea gravel for equipment up to 5 feet high. NOTE: An initial fill level of 12 inches will compress to about a 9- inch depth of surfacing over time. The surfacing will also compact, displace, and settle, and should be periodically refilled to maintain at least a 9- inch depth.

Use a minimum of 6 inches of protective surfacing for play equipment less than 4 feet in height. If maintained properly, this should be adequate. (At depths less than 6 inches, the protective material is too easily displaced or compacted.)

NOTE: Do not install home playground equipment over concrete, asphalt, or any other hard surface. A fall onto a hard surface can result in serious injury to the equipment user. Grass and dirt are not considered protective surfacing because wear and environmental factors can reduce their shock absorbing effectiveness. Carpeting and thin mats are generally not adequate protective surfacing. Ground level equipment – such as a sandbox, activity wall, playhouse or other equipment that has no elevated play surface – does not need any protective surfacing. Use containment, such as digging out around the perimeter and/or lining the perimeter with landscape edging. Don't forget to account for water drainage. Check and maintain the depth of the loose-fill surfacing material. To maintain the right amount of loose- fill materials, mark the correct level on play equipment support posts. That way you can easily see when to replenish and/or redistribute the surfacing. Do not install loose fill surfacing over hard surfaces such as concrete or asphalt.

Poured-In-Place Surfaces or Pre-Manufactured

Rubber Tiles—You may be interested in using surfacing other than loose-fill materials – like rubber tiles or poured-in-place surfaces.

Installations of these surfaces generally require a professional and are not “do-it-yourself” projects.

Review surface specifications before purchasing this type of surfacing. Ask the installer/manufacturer for a report showing that the product has been tested to the following safety standard: ASTM F1292 Standard Specification for Impact Attenuation of Surfacing Materials within the Use Zone of Playground Equipment. This report should show the specific height for which the surface is intended to protect against serious head injury. This height should be equal to or greater than the fall height – vertical distance between a designated play surface (elevated surface for standing, sitting, or climbing) and the protective surfacing below – of your play equipment.

Check the protective surfacing frequently for wear.

MADE IN CHINA

12 Month Warranty

Thank you for your purchase from Kmart.

Kmart Australia Ltd warrants your new product to be free from defects in materials and workmanship for the period stated above, from the date of purchase, provided that the product is used in accordance with accompanying recommendations or instructions where provided. This warranty is in addition to your rights under the Australian Consumer Law.

Kmart will provide you with your choice of a refund, repair or exchange (where possible) for this product if it becomes defective within the warranty period. Kmart will bear the reasonable expense of claiming the warranty. This warranty will no longer apply where the defect is a result of alteration, accident, misuse, abuse or neglect.

Please retain your receipt as proof of purchase and contact our Customer Service Centre on

JCA Collective

Email: service@jcacollective.com

Phone Number: +61 423 259 751

Office Hours: Monday to Friday 9am to 5pm

Our goods come with guarantees that cannot be excluded under the Australian Consumer Law. You are entitled to a replacement or refund for a major failure and compensation for any other reasonably foreseeable loss or damage. You are also entitled to have the goods repaired or replaced if the goods fail to be of acceptable quality and the failure does not amount to a major failure.

For New Zealand customers, this warranty is in addition to statutory rights observed under New Zealand legislation.

The date of purchase:

The components will deteriorate over time.

WARNING Suitable for children 3+ years. Maximum user weight 50kg. This unit is designed to be used safely for one child only. Only for domestic use. Outdoor use only. This must be assembled by an adult before use. Adult supervision is recommended. Falling hazard. Small parts, choking hazard.