

88912

6+ Years
TM

LASER X

Real-Life Laser Gaming Experience

Dear Customer,
NSI International, Inc. is the manufacturer of this product. We hope you enjoy your Laser X product. If you find that we have made an error or if something is missing or damaged, let us know so that we can correct the problem for you. Please include the following:

- Name of item
- Purchase price (please include sales slip)
- Place of purchase
- Date of purchase
- Model number
- Brief description of the problem

Send all correspondence to:



HUNTER LEISURE PTY LTD
94 KEILOR PARK DRIVE
TULLAMARINE VIC 3043
AUSTRALIA
www.hunterleisure.com.au
Tel: 03 9287 9888

www.buylaserx.com.au

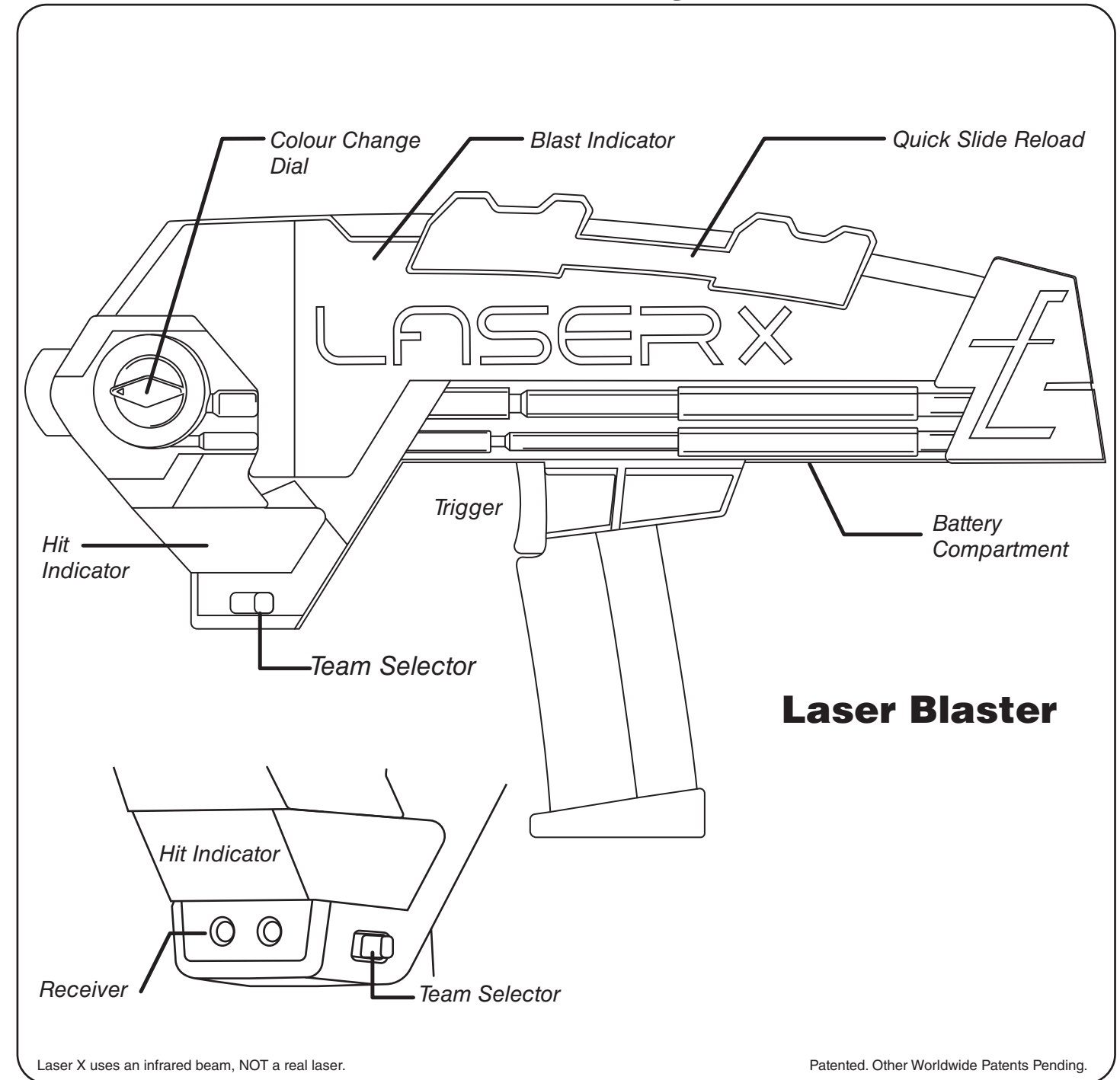

Laser X uses an infrared beam, NOT a real laser.

Patented. Other Worldwide Patents Pending.

BATTERY SAFETY INFORMATION

- Non-rechargeable batteries are not to be recharged.
- Rechargeable batteries are to be removed from the Laser Blaster before being charged.
- Rechargeable batteries are only to be charged under adult supervision.
- Different types of batteries or new and used batteries are not to be mixed.
- Only batteries of the same or equivalent type as recommended are to be used.
- Batteries are to be inserted with the correct polarity (+ and -).
- Exhausted batteries are to be removed from the Laser Blaster.
- The supply terminals are not to be short-circuited.
- Keep instruction sheet for reference since it contains important information.
- Do not mix old and new batteries.
- Do not mix alkaline, standard (carbon-zinc) or rechargeable (nickel-cadmium) batteries.
- Alkaline Battery is Recommended.

FCC:

This device complies with part 15 of the FCC Rules. Operation is subject to the following two conditions: (1) This device may not cause harmful interference, and (2) this device must accept any interference received, including interference that may cause undesired operation.

Caution: changes or modifications not expressly approved by the party responsible for compliance could void the user's authority to operate the equipment.

NOTE: This equipment has been tested and found to comply with the limits for a Class B digital device, pursuant to Part 15 of the FCC Rules. These limits are designed to provide reasonable protection against harmful interference in a residential installation. This equipment generates, uses and can radiate radio frequency energy and, if not installed and used in accordance with the instructions, may cause harmful interference to radio communications. However, there is no guarantee that interference will not occur in a particular installation. If this equipment does cause harmful interference to radio or television reception, which can be determined by turning the equipment off and on, the user is encouraged to try to correct the interference by one or more of the following measures:

- Reorient or relocate the receiving antenna.
- Increase the separation between the equipment and receiver.
- Connect the equipment into an outlet on a circuit different from that to which the receiver is connected.
- Consult the dealer or experienced radio/TV technician for help.

READ THIS BEFORE YOU PLAY

Adult Supervision Required.

6+ Years

Laser X is a sport and should be played with the same care as you would any other sport.



IMPORTANT! Do Not climb onto or jump from trees, playground equipment, fences, ladders or any high places when wearing Laser X Gear as it can get caught and be a strangulation or choking hazard!

Do not play Laser X in streets, parking lots or anywhere near moving cars or other vehicles.

Installing Batteries:

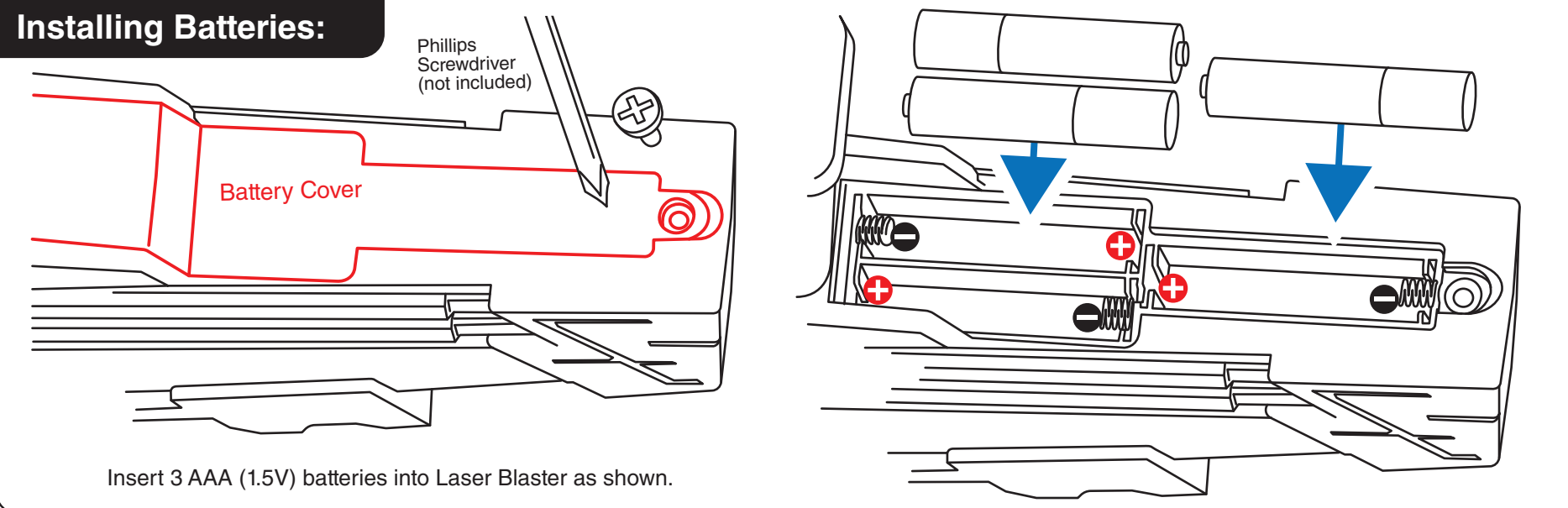

Game Play:

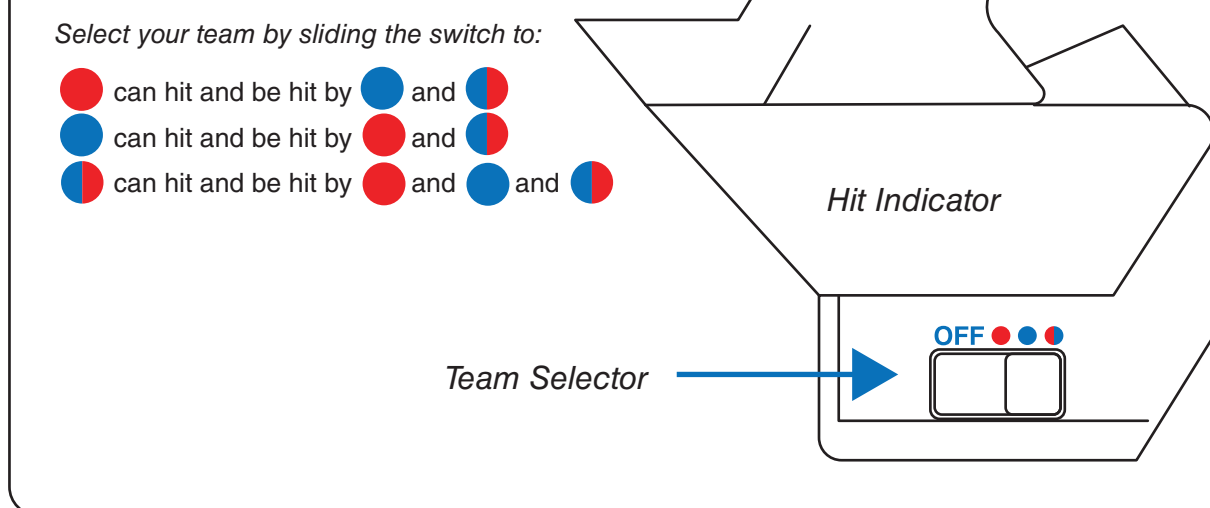

Blaster Colour Change:

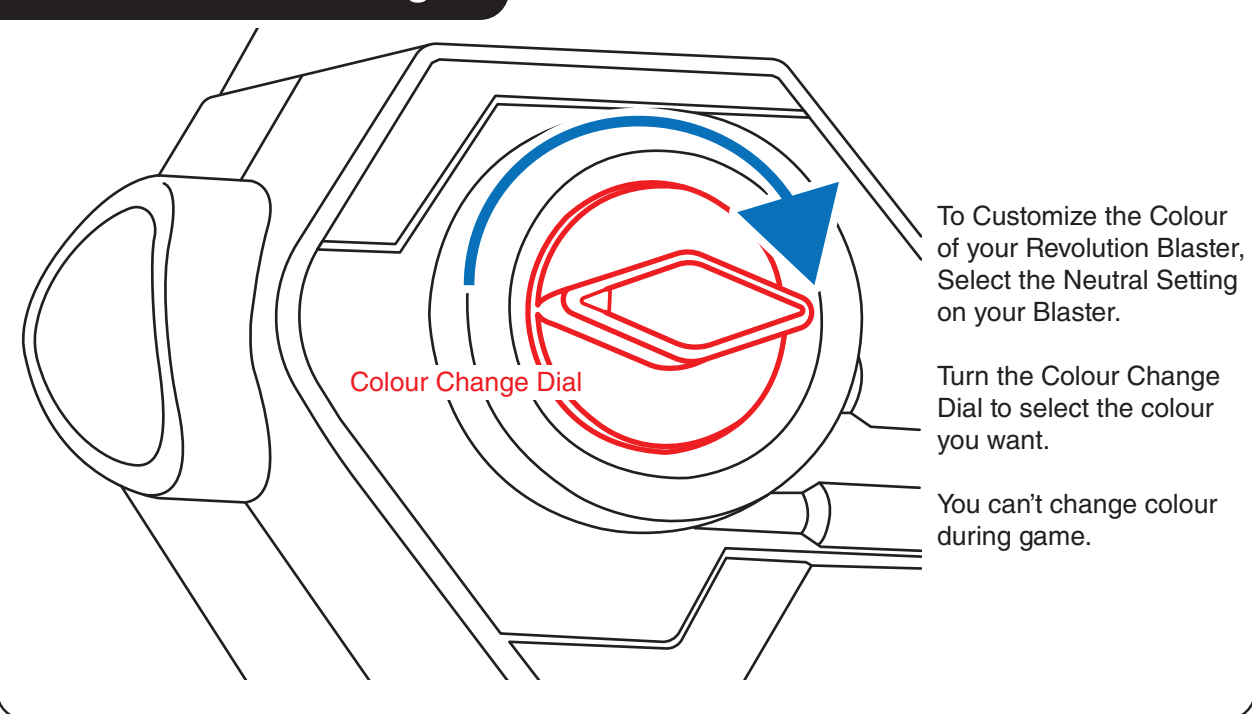

Blaster Reload:

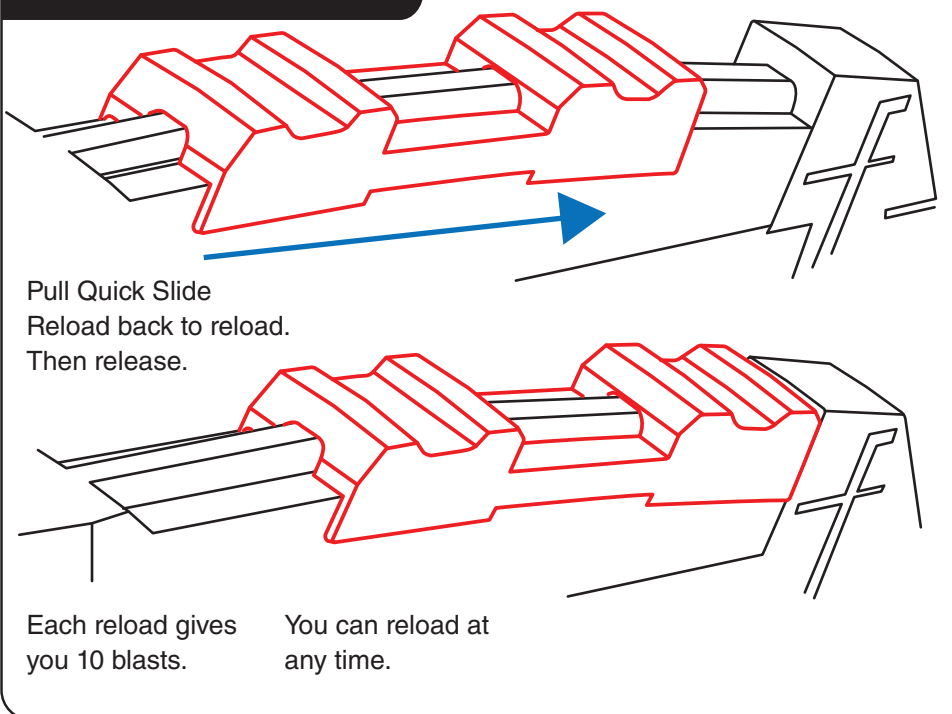

Scoring Hits:

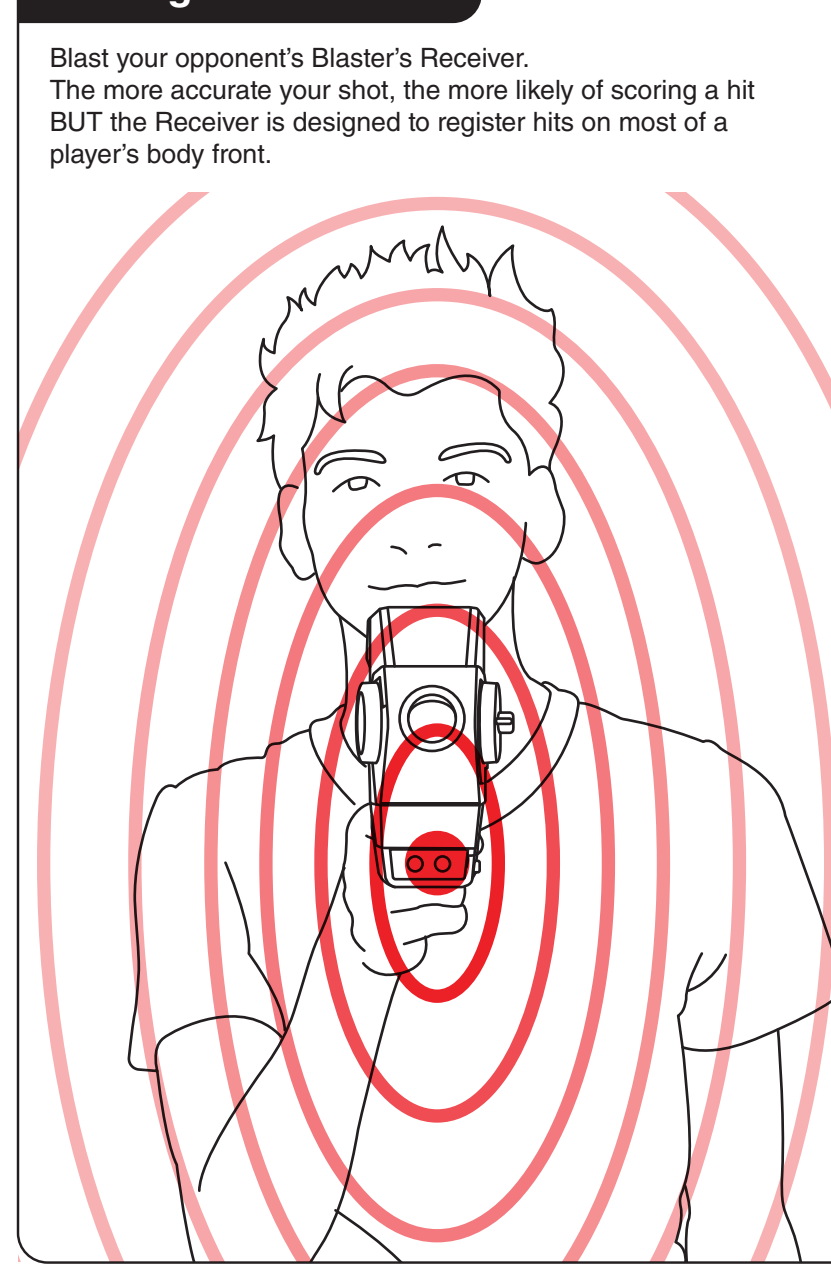

During Game Play:

- Blasters can hit Receiver up to 90 m away.
- With each hit, the Game Life Indicator will change from Green to Red.
- 8 Hits and you are out.
- For each minute you are not hit, you automatically get one hit "back".
- When you are out, you must turn your Blaster OFF and re-select your team to start a new game.

Tips:

- Very bright sunlight will decrease Laser Blast Range.
- Indoors, Laser Blaster beams can be bounced off walls and mirrors to hit your opponent.
- You can blast through windows.
- Turn your Laser X Gear to OFF when not in use. Leaving it in any of the team settings will drain batteries.
- If your Laser X Gear is not working properly, replace the batteries with BRAND NEW batteries.

Be a Good Sport:

- Don't cover your Blaster's Receiver or hide it.
- Don't reset your Blaster during play.