

GEORGE FOREMAN®



JUMBO GRILL - WHITE GR18892AU

Instructions & Warranty

www.georgeforeman.com.au

www.georgeforeman.co.nz

GEORGE FOREMAN and logo are trade marks of Spectrum Brands, Inc., or one of its subsidiaries.

©2021 Spectrum Brands, Inc.

IMPORTANT SAFEGUARDS

When using electrical appliances, basic safety precautions should always be followed.

1. To protect against electrical hazards do not immerse the power cord, plug or grill in water or any other liquid.
2. Do not use in the bathroom or near any source of water. Do not use outdoors. 
3. Always use the appliances handles as some parts will be hot. The temperature of accessible surfaces/parts may become very hot when the appliance is operating and will remain hot for some time after the appliance has been switched off..
4. Do not touch the hot cooking surfaces.
5. This appliance is not intended for use by persons (including children) with reduced physical, sensory or mental capabilities, or lack of experience and knowledge, unless they have been given supervision or instruction concerning use of the appliance by a person responsible for their safety.
6. Always turn off and unplug from the power outlet before cleaning the appliance.
7. To disconnect, turn off the wall power outlet, then grasp the plug and remove from wall power socket. Never pull by the cord.
8. Do not operate this appliance with a damaged cord or plug or after the appliance has malfunctioned, or been dropped or damaged in any manner. Contact Customer service for replacement, examination, repair or adjustment.
9. There are no user serviceable parts. If the power cord or appliance is damaged, it must be replaced or repaired by the manufacturer or similarly qualified person in order to avoid a hazard.
10. Do not use on an inclined plane or unstable surface.
11. Do not move the appliance when in use.
12. Do not cover the appliance when in use.
13. Always take care when removing food after cooking as it is hot.
14. Food may burn. Always monitor when using this appliance.
15. Do not use the appliance near or below any curtains or other combustible materials.
16. Keep the appliance and the power cord away from the edge of tables or countertops and out of reach of children and persons with disabilities.
17. Do not cook food wrapped in plastic film or polythene bags. It will cause a fire hazard.
18. Always clean the appliance after use.
19. Follow the instructions when cleaning this appliance.
20. Do not place on or near any heat sources.
21. Do not leave the appliance unattended when in use.
22. Do not use appliance for other than its intended purpose.
23. This appliance is not a toy. Children should be supervised to ensure they do not play with the appliance.
24. This appliance is not intended to be operated by means of an external timer or separate remote control system.
25. For added safety, electrical appliances should be connected to a power outlet that is protected by a residual current device (RCD), also often referred to as a 'Safety Switch'. Your switchboard may already incorporate an RCD. If unsure, call an electrician for verification and fitting if necessary.

26. This appliance is intended to be used in household and similar applications such as:
- staff kitchen areas in shops, offices and other working environments;
 - by clients in hotels, motels and other residential type environments;
 - bed and breakfast environments;
 - farm houses.



HOT SURFACE:

This symbol indicates that surfaces of the appliance may be hot and care should be taken to avoid possible burns.

**SAVE THESE INSTRUCTIONS
THIS APPLIANCE IS FOR HOUSEHOLD USE ONLY**

Congratulations on the purchase of your George Foreman Grill. Each unit is manufactured to ensure safety and reliability. Before using the appliance for the first time, please read the instruction book carefully and keep it for future reference. Pass it on if you pass on the appliance.

When using electrical appliances, basic safety precautions should always be followed.

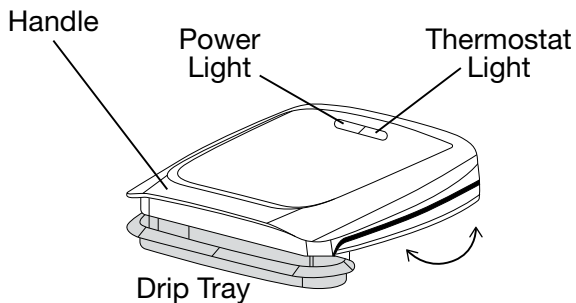
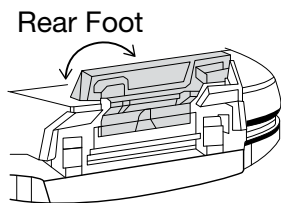
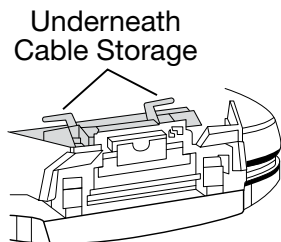

BEFORE USING YOUR GRILL

- Remove any packaging and labels from the appliance.
- Wipe the exterior and cooking plates with a damp cloth to remove any dust.
- Place the grill on a stable, level, heat-resistant surface, in a well ventilated area, with the lid closed.
- Plug the power cord into a power outlet and turn the power on. The power light will glow.
- When the grill reaches operating temperature, the thermostat light will glow. It will then cycle on and off as the thermostat operates to maintain the temperature.

Note: When using your grill for the first time, the unit may emit a fine smoke vapour and scent. This is normal and is caused by the first heating of the new elements and new cooking plates.

- Switch the power off at the wall power outlet, allow the grill to cool then wipe over the cooking plates once again using a damp cloth.

CONDITION THE COOKING PLATES

Note: Conditioning the cooking plates will help prolong the life of the non-stick coating.

- Lift the lid and wipe the upper and lower cooking plates lightly with cooking oil.
- Switch the power on at the wall power outlet. The power light will illuminate. Allow the thermostat light to cycle on and off at least 2 times.
- Switch the power off at the wall power outlet, remove the plug and allow the grill to cool.
- Wipe off any excess oil with a dry paper towel and close the lid.

FLAT FOR SANDWICHES OR TILTED FOR GRILLING?

- You may raise the rear foot to tilt the grill and speed the flow of fat into the drip tray, or leave it flat to prevent fillings such as melting cheese moving towards the front of the grill.
- Grill meat, burgers, anything that exudes fat, on the tilt.
- Grill sandwiches, panini, foods with fluid fillings like melting cheese, on the flat.
- Centre the drip tray under the front of the grill, to catch run-off.

USING YOUR GRILL

- Place the grill on a flat, level, heat resistant surface, leaving enough space around all sides to allow heat to flow without damage to cabinets, walls and overhanging curtains.
- Either raise the rear foot to tilt the grill or leave flat and under the base of the grill.
- Place the drip tray under the front of the grill.
- Using the handle, close the lid.
- Plug the power cord into a power outlet and turn the power on. The light will illuminate.
- The green thermostat light will illuminate when the grill reaches operating temperature.

Note: The thermostat light will cycle on and off during cooking as the grill maintains temperature.

- Using the handle, lift the lid and carefully place items to be cooked onto the bottom cooking plate.

- Close the lid, allowing the grill to begin cooking from both sides at once. The grill is designed with a floating hinge to cope with thick or oddly shaped foods allowing even cooking.
- The grill plates should be parallel to avoid uneven cooking.

Note: Normal cooking times are significantly reduced as the grill cooks from both sides at once. As a rule of thumb, cooking times are generally halved when compared to traditional 'one side at a time' grilling.

CAUTION: Do not leave this appliance unattended during use.

- Monitor food whilst cooking to ensure food is fully cooked and does not burn.
- When finished cooking switch the power off at the power outlet and remove the plug.
- Using an oven mitt or tea towel, carefully open the lid.
- Remove food using the plastic spatula or a non-metallic utensil.

Note: Be sure to always use either silicone, plastic or wooden utensils so as not to scratch the non-stick surface. Never use metal tongs, forks or knives as these can damage the coating of the cooking plates.

- Allow the grill to cool completely.

CAUTION: Be sure the drip tray contents have cooled before removing drip tray.

- Once cool, the drip tray may be removed and emptied and the grill can be cleaned.

Note: Where the top and bottom plates make contact, the non-stick surfaces may show signs of wear. This is purely cosmetic and will not affect the operation of the grill.

CLEANING

CAUTION: Always unplug from the wall power outlet and allow the grill to cool before cleaning.

Do not immerse the grill in water or in any other liquid.

- Before cleaning, switch off the power and remove the plug from the wall power outlet.
- Place the drip tray under the front of the grill.

CAUTION: Take extra care when cleaning the cooking plates, making sure the grill lid does not close accidentally and cause injury. Hold the grill open using the handle when cleaning the cooking plates.

- Wipe the cooking plates with paper towel to clean off any excess fat or food. Then wipe with a cloth or soft sponge dampened in warm soapy water, allowing any run off to be caught in the drip tray. Wipe dry with a soft cloth or paper towel.
- To remove stubborn spots, gently rub with a cloth dampened with cooking oil while the cooking plates are still warm (NOT hot).

CAUTION: Do not use scouring pads, scrapers, or metal objects to clean the cooking plates. They will damage the surface.

- Remove the drip tray and wash in warm soapy water using a soft sponge, nylon brush or soft sponge. Rinse and dry thoroughly.
- To clean the grill exterior, wipe with a cloth dampened in warm soapy water. Wipe dry with paper towel.

NOTE: To purchase a George Foreman grill sponge, please contact customer service.

STORAGE

- Ensure that the grill is switched off and the plug is removed from the power outlet.
- Ensure all parts have been cleaned and dried thoroughly before storing.
- Once the grill has cooled wrap the cord around the guides in the base of the grill and store in a clean, dry place.

DISPOSAL / RECYCLE

Legislation in some localities mandates that e-waste (anything with a plug, battery or cord) is disposed of through controlled recycling facilities and must not be disposed of in general household waste. For more information about recycling of electrical and battery operated appliances, please contact your local council or your local household waste disposal service.

QUICK COOKING GUIDE

Use these times purely as a guide. Cooking times are based on fresh, fully defrosted food. Check food is cooked through before serving. If in doubt, cook it a bit more. Cook meat, poultry, and any derivatives (mince, burgers, etc.) until the juices run clear. Cook fish until the flesh is opaque throughout. When cooking pre-packed foods, follow any guidelines on the package or label.

FOOD	MINUTES	FOOD	MINUTES
BEEF		SEAFOOD	
Fillet rare	3	Kebab, 25mm2	4-6
Fillet medium	4	Prawn (large)	2-3
Fillet well done	5	Snapper fillet	3-5
Loin steak	7-8	Salmon fillet	3-4
Burger, 50g	5-6	Scallop	1-2
Burger, 100g	7-8	Tuna steak	6-8
Burger, 200g	8-9	VEGETABLES	
Kebab, 25mm2	7-8	Asparagus	3-4
Round steak	5-7	Carrot, sliced	5-7
Sausage, thin	5-6	Eggplant, sliced/cubes	8-9
Sausage, thick	7-8	Onions, thin slices	5-6
Sirloin	7-9	Capsicum, thin slices	6-8
T-Bone	8-9	Potato, slices/cubes	7-9
PORK		Squash, slices/cubes	6-8
Cutlets	5-6	FRUIT	
Kebab, 25mm2	7-8	Apple, halves/slices	6-8
Sausage, thin	5-6	Banana, lengthway slices	3-4
Sausage, thick	7-8	Nectarine, halves/slices	3-5
Fillet	4-6	Peach, halves/slices	3-5
CHICKEN/TURKEY		Pineapple, slices	3-7
Chicken breast pieces	5-7	SNACKS	
Burger, 100g	4	Sandwich, cheese	2-3
Burger, 200g	5	Sandwich, cooked meat	5-7
Kebab, 25mm2	7-8	Calzone	8-9
Chicken thigh	5-7	Hot dog	2-3
Turkey breasts, thin slices	3-4	Quesadillas	2-3
LAMB			
Kebab, 25mm2	7-8		
Cutlet	2-3		

Spectrum Brands Australia Pty Ltd

Locked Bag 3004 Braeside
Victoria 3195 Australia

Customer Service in Australia

TollFree: 1800 623 118
Email: info@spectrumbrands.com.au
Website: www.spectrumbrands.com.au

Spectrum Brands New Zealand Ltd

PO Box 9817 Newmarket
Auckland 1149 New Zealand

Customer Service in New Zealand

TollFree: 0800 736 776
Email: service@spectrumbrands.co.nz
Website: www.spectrumbrands.co.nz

Spectrum Brands Australia Pty Ltd and Spectrum Brands New Zealand Ltd Warranty Against Defects

In this warranty:

Australian Consumer Law means the Australian consumer law set out in Schedule 2 to the Competition and Consumer Act 2010;

CGA means the New Zealand Consumer Guarantees Act 1993;

Goods means the product or equipment which was accompanied by this warranty and purchased in Australia or New Zealand, as the case may be;

Manufacturer, We or **us** means:

1. for Goods purchased in Australia, Spectrum Brands Australia Pty Ltd ABN, 78 007 070 573;
or
2. for Goods purchased in New Zealand, Spectrum Brands New Zealand Ltd, as the case may be, contact details as set out at the end of this warranty;

Supplier means the authorised distributor or retailer of the Goods that sold you the Goods in Australia or in New Zealand; and

You means you, the original end-user purchaser of the Goods.

1. Our goods come with guarantees that cannot be excluded under the Australian Consumer Law, or the CGA. You are entitled to a replacement or refund for a major failure and compensation for any other reasonably foreseeable loss or damage. You are also entitled to have the goods repaired or replaced if the goods fail to be of acceptable quality and the failure does not amount to a major failure.
2. The benefits provided by this Warranty are in addition to all other rights and remedies in respect of the Goods which the consumer has under either the Australian Consumer Law or the CGA. The original purchaser of the Goods is provided with the following Warranty subject to the Warranty Conditions:
3. We warrant the Goods for all parts defective in workmanship or materials for a (**Warranty Period**) period of 2 years from the date of purchase.

If the Goods prove defective within the Warranty Period by reason of improper workmanship or material, we may, at our own discretion, repair or replace the Goods without charge.

Warranty Conditions

4. The Goods must be used in accordance with the manufacturer's instructions. This Warranty does not apply should the defect in or failure of the Goods be attributable to misuse, abuse, accident or non-observance of manufacturer's instructions on the part of the user. As far as the law permits, the manufacturer does not accept liability for any direct or consequential loss, damage or other expense caused by or arising out of any failure to use the Goods in accordance with the manufacturer's instructions.
5. Exhaustible components (such as batteries, filters and brushes) of the Goods are included under this Warranty only where there is a defect in workmanship or materials used.
6. The warranty granted under clause 3 is limited to repair or replacement only.
7. Any parts of the Goods replaced during repairs or any product replaced remain the property of the manufacturer. In the event of the Goods being replaced during the Warranty Period, the warranty on the replacement Goods will expire on the same date as for the Warranty Period on the original Goods which are replaced.
8. In order to claim under the warranty granted under clause 3 you must:
 - (a) Retain this warranty with your receipt/proof of purchase; and
 - (b) Return the Goods to us at the relevant address or to the Supplier by prepaid freight within the Warranty Period accompanied with (i) the legible and unmodified original proof of purchase, which clearly indicates the name and address of the Supplier, the date and place of purchase, the product name or other product serial number and (ii) this warranty.
9. This warranty is immediately void if:
 - (a) Any serial number or appliance plate is removed or defaced;
 - (b) The Goods have been serviced or otherwise repaired by a person not authorised to do so by us or where non approved replaced parts are used.
10. The Goods are designed for domestic use only. The Goods must be connected to the electrical voltage requirements as specified in the ratings label located on the Goods.
11. This warranty does not cover the cost of claiming under the warranty or transport of the Goods to and from the Supplier or us.
12. This warranty is only valid and enforceable in Australia against Spectrum Brands Australia Pty Ltd and in New Zealand against Spectrum Brands New Zealand Ltd.

Contact us or the Supplier for further details.

Register your product online

If you live in Australia please visit: www.spectrumbrands.com.au/warranty

If you live in New Zealand Please visit: www.spectrumbrands.co.nz/warranty

Registration of your warranty is not compulsory, it gives us a record of your purchase AND entitles you to receive these benefits: Product information; Hints and tips; Recipes and news; Information on special price offers and promotions.

Any questions? Please contact Customer Service for advice.

NOTES:

GEORGE FOREMAN[®]

www.georgeforeman.com.au

www.georgeforeman.co.nz

GEORGE FOREMAN and logo are trade marks of Spectrum Brands, Inc., or one of its subsidiaries.

©2021 Spectrum Brands, Inc.