

anko

Instruction Manual

Keycode: 43089604

LED Spot Light

Please read all the information carefully before you use the device to avoid accidents and keep it for future reference.

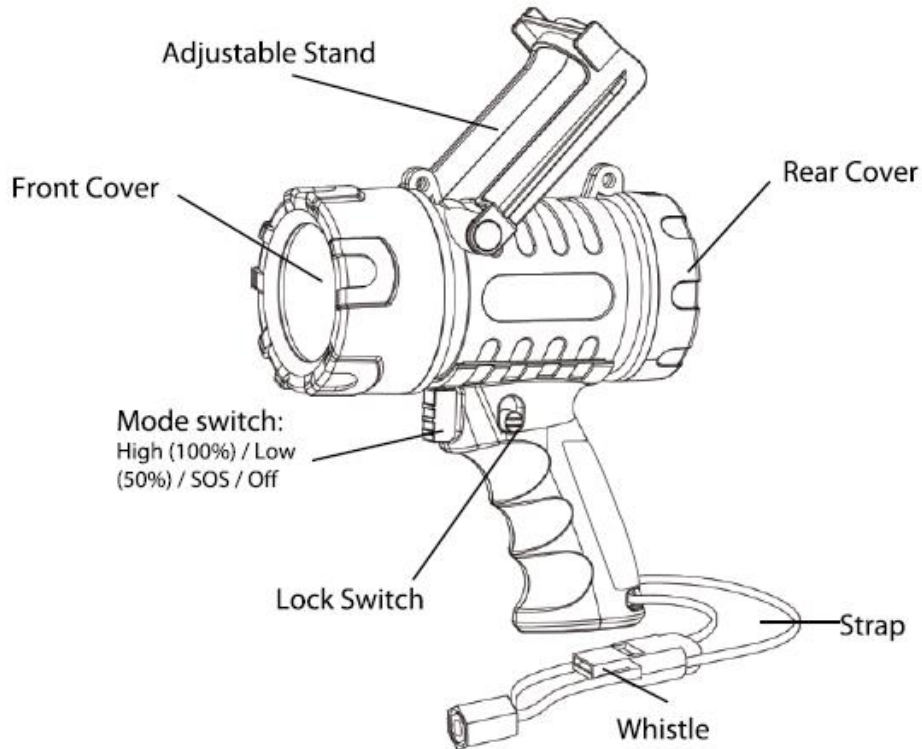

Packaging include:

LED spot light with whistle x 1

Single wall charger x 1

Single car charger x 1 (open light rear cover to find it)

Micro USB charging cable x 1 (open light rear cover to find it)

Instruction manual x1

Specification:

Car charger:

Input: DC 12-24V

Output: DC 5V1A max

Wall charger:

Input: 100-240V~50/60Hz

Output: DC 5V1A max

Built in 2500mAh battery

Charging time: Up to 5 hours.

IP44

Operation Instructions

Lock Switch: Lock/Unlock by pushing this switch upwards/downwards to maintain your preferred mode function.

Mode Switch:

First press: 100% brightness

Second press: 50% brightness

Third press: SOS .

Forth press: Off

Charging the light:

1. Open the rear cover, connect the Micro USB cable (Included) to the spot light.
2. Connect a USB power adapter (included) or a car charger (included) will be required.

Note : When charging, the LED indicator light will turn red and turn green when fully charged.

Attention:

1. Never dismantle the product without due permission, else this may nullify warranty clauses.
2. This is not a toy. Keep it out of reach from small children.
3. Do not use spotlight when it is charging.
4. Never look directly into the spot light when illuminated.

12 Month Warranty

Thank you for your purchase from Kmart.

Kmart Australia Ltd warrants your new product to be free from defects in materials and workmanship for the period stated above, from the date of purchase, provided that the product is used in accordance with accompanying recommendations or instructions where provided. This warranty is in addition to your rights under the Australian Consumer Law.

Kmart will provide you with your choice of a refund, repair or exchange (where possible) for this product if it becomes defective within the warranty period. Kmart will bear the reasonable expense of claiming the warranty. This warranty will no longer apply where the defect is a result of alteration, accident, misuse, abuse or neglect.

Please retain your receipt as proof of purchase and contact our Customer Service Centre on 1800 124 125 (Australia) or 0800 945 995 (New Zealand) or alternatively, via Customer Help at Kmart.com.au for any difficulties with your product. Warranty claims and claims for expense incurred in returning this product can be addressed to our Customer Service Centre at 690 Springvale Rd, Mulgrave Vic 3170.

Our goods come with guarantees that cannot be excluded under the Australian Consumer Law. You are entitled to a replacement or refund for a major failure and compensation for any other reasonably foreseeable loss or damage. You are also entitled to have the goods repaired or replaced if the goods fail to be of acceptable quality and the failure does not amount to a major failure.

For New Zealand customers, this warranty is in addition to statutory rights observed under New Zealand legislation.