

PARK PRO SCOOTER INSTRUCTIONS

Keycode: 43094318

WARNING! Assembly by an adult.

WARNING! Always wear a helmet and protective pads. Do not use scooter at night. Do not use on wet surfaces, uneven or unpaved road. Do not use on public roads.

WARNING! This scooter is not designed for off-road use.

WARNING! Not suitable for children under 7 years old. User's maximum weight: 100Kg.

This product complies with EN 14619 Class A.

Remove the scooter and all the parts from the box. Set out all the parts and read the assembly instructions prior to use. Keep the packaging until assembly is complete.

General instructions

- This scooter must be assembled by a responsible adult. Prior to use, make sure that the scooter has been assembled properly. Remove all the parts which are not necessary for play before giving the scooter to your child. Due to the skill it requires, the scooter must be used with care in order to avoid falls or collisions likely to injure the user or others.
- To use with suitable protective equipment, including a helmet, shoes, elbow, wrist and knee protectors.
- The scooter is not a toy for children under the age of 7 years.
- Advise to the user to check the limitation of use according to regulations of road safety.

Directions

- a) The scooter can be dangerous and can lead to a traffic accident when used on public highways. Not to be used on public roads.
- b) It is best used on a flat, clean surface, free of gravel and grease.
- c) Avoid bumps and drainage grates that may cause an accident.
- d) The scooter does not include any headlights or lights. It is therefore not suitable for use at night or during periods when visibility is limited.
- e) Do not allow more than one child to ride the scooter at the same time.

Before and after use

- Check all screws and fittings are secure before giving to a child.
- Ensure all locking devices are engaged. Ensure there are no broken components.

Assembly Instructions:

Handlebar assembly

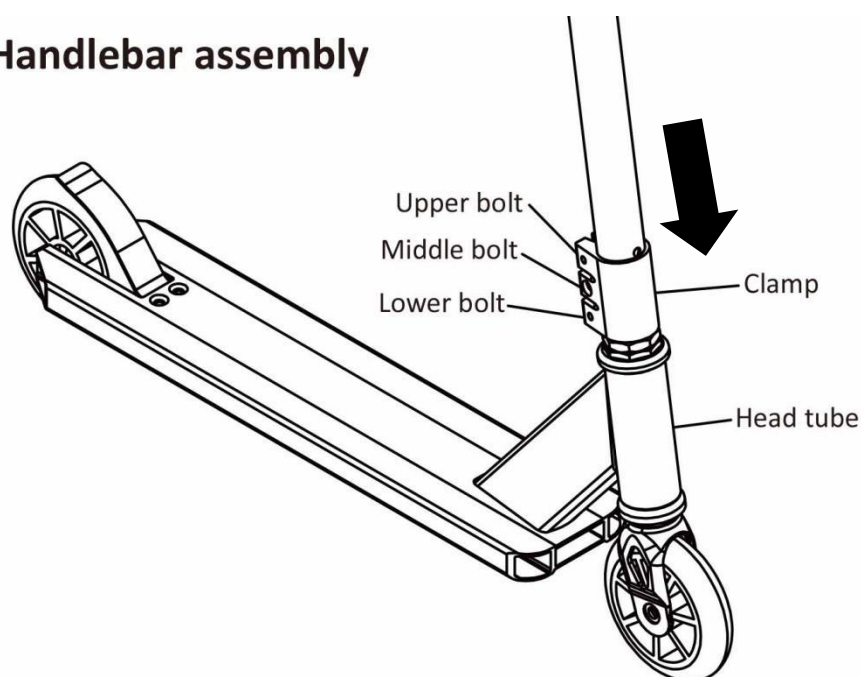

1. Loosen the clamp and slide the handlebar stem over the fork column until it touches the lock nut.
2. Tighten the upper bolt one quarter of a turn, the middle bolt one quarter of a turn and then the lower bolt one quarter of a turn using the hex key provided. Repeat until the clamp is tight and the handlebars are secure.
3. Make sure the wheel faces forward when the handlebars are held facing straight.

WARNING! Failure to tighten the clamp fully will result in the handlebars not being secure and the scooter will be unsafe to ride. Over tightening one bolt before the other will make it impossible to tighten the clamp fully.

Use

- Hold both handgrips firmly. Put one foot towards the front of the deck, push off the ground to propel the scooter forward with other foot. Both feet can fit on the deck when desired speed has been reached.
- Practice foot positioning at slower speed until you build skill and experience. Shifting your foot position, or lifting or placing your feet while travelling affects the stability of the scooter. You have to learn to maintain control while you move your feet on and off the deck of the scooter.
- Braking: Brake is located at the rear, when necessary, press down on it to slow down. Press down gradually in order to prevent skidding or loss of stability. The metal or aluminum brake may heat up after multiple uses. Avoid touching it during and after use.
- Shoes are mandatory and we strongly advise you to wear long pants and long sleeve

shirts to avoid injury if you fall.

Care Instructions

A. Wheel bearings: Avoid going through water, oil or sand as this can damage wheel bearings.

To look after the wheel bearings, systematically check that the wheels turn properly by turning the scooter upside-down and using your hand to spin the wheels. If the wheels do not spin they must then be removed to check their condition. First unscrew the wheel axle, remove the axle and detach the wheel, then carefully push the two wheel bearings out of their housing. If they are chipped or dented, new ones should be bought. If there is no visible damage, they must then be oiled. To do this, remove all traces of grease, mud or dust with a kitchen towel or cloth, and re-oil them with a grease spray or by leaving them to soak overnight in oil [turn them several times in the oil first]. Remove and reassemble the wheel bearings and axles, followed by the wheel, onto the scooter. Proceed in the same manner for the other wheel.

B. Wheels: The wheels wear down with time and can be pierced if over used on rough surfaces. The back wheel on which the brake is applied is particularly affected after several hours of braking. In the interest of safety, both wheels should be checked regularly and changed if necessary.

C. Modifications: The original product must by no means be modified except for the maintenance-related changes mentioned in these instructions.

D. Nuts and axles: These should be checked regularly. They can become loose after a while in which case they should be tightened. They can become worn and not tightened properly, in which case they should be replaced.

MADE IN CHINA

FOR AU / NZ: IMPORTED FOR KMART
STORES IN AUSTRALIA AND NEW ZEALAND.