









Assembly Instructions







43116126 Panelled 3 Drawers

WARNING: DO NOT USE THIS UNIT UNLESS ALL BOLTS AND SCREWS ARE FIRMLY SECURED. DO NOT KNOCK OR DRAG THIS UNIT. USE ONLY ON A FLAT SURFACE. FAILURE TO FOLLOW THESE WARNINGS COULD RESULT IN SERIOUS INJURY. THIS PACKAGE CONTAINS SMALL PARTS AND SHARP POINTS, KEEP AWAY FROM CHILDREN AND BABIES.

MAXIMUM TOTAL LOADING WEIGHT: 5KG FOR TOP PANEL AND 3KG FOR EACH DRAWER, 14KG IN TOTAL.

Hardware list

	a		28PCS
	b		28PCS
	c	6X30mm	8PCS
	d	4X30mm	16PCS
	e	3X12mm	24PCS
	f	4X10mm	16PCS
	g		3PCS
	h		3PCS
	i		3PCS

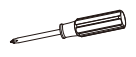
	j		3PCS
	k		3PCS
	m	4X14mm	3PCS
	n	3X14mm	6PCS
	o		6PCS
	p		2PCS
	q		2PCS
	Tool required Philips Head Screw Driver (Not Provided)		

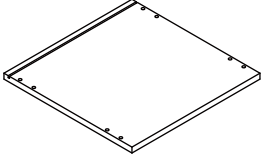
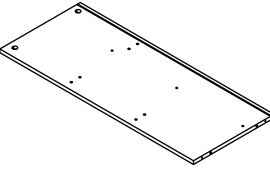
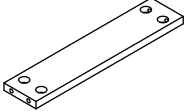
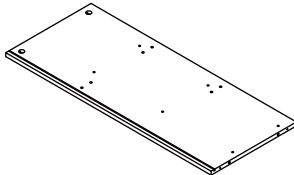
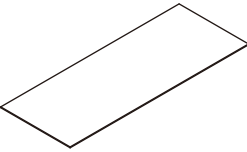
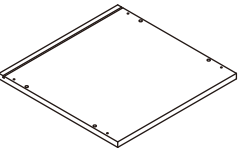
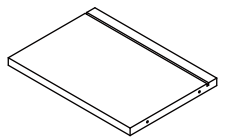
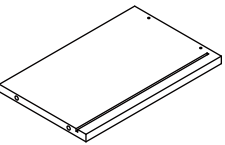
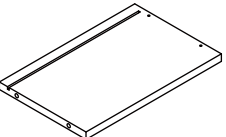
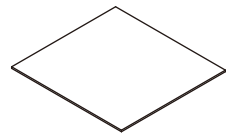
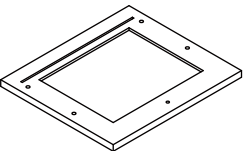
					
A	1 PC	B	1 PC	C	3 PCS
					
D	1 PC	E	1 PC	F	1 PC
					
G	3 PCS	H	3 PCS	J	3 PCS
					
K	3 PCS	L	3 PCS		

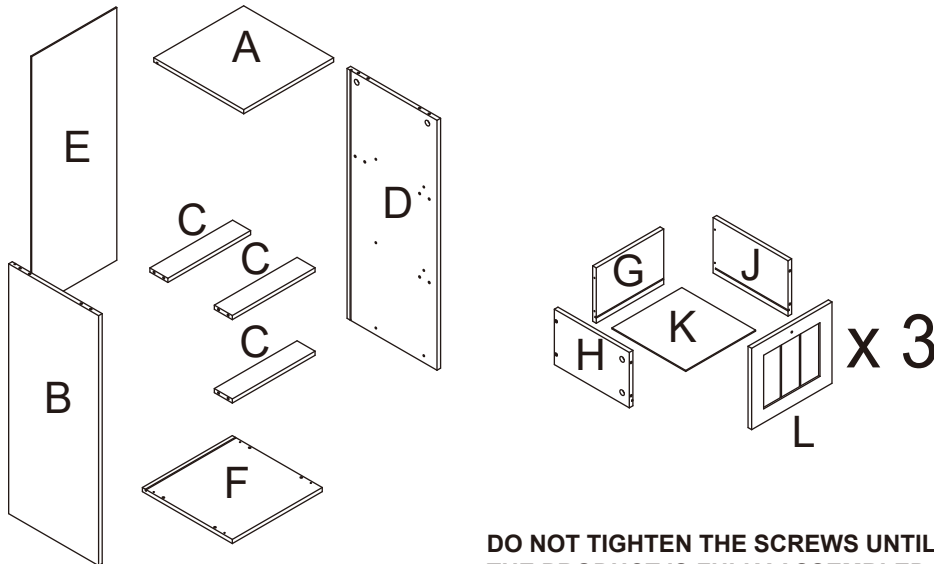

DO NOT TIGHTEN THE SCREWS UNTIL THE PRODUCT IS FULLY ASSEMBLED.

STEP 1

-  X6
-  X4
-  X6
-  X3

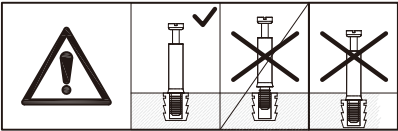
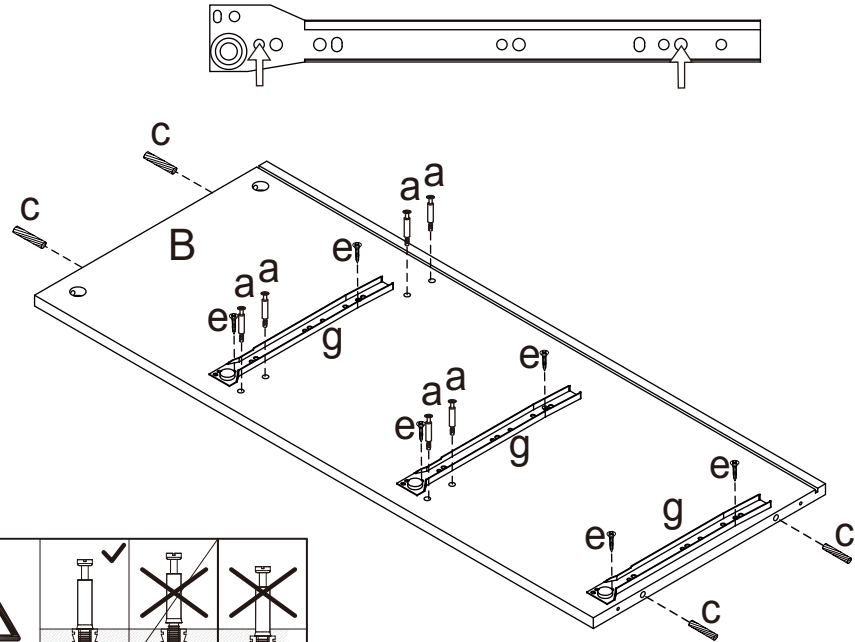

STEP 2

-  X6

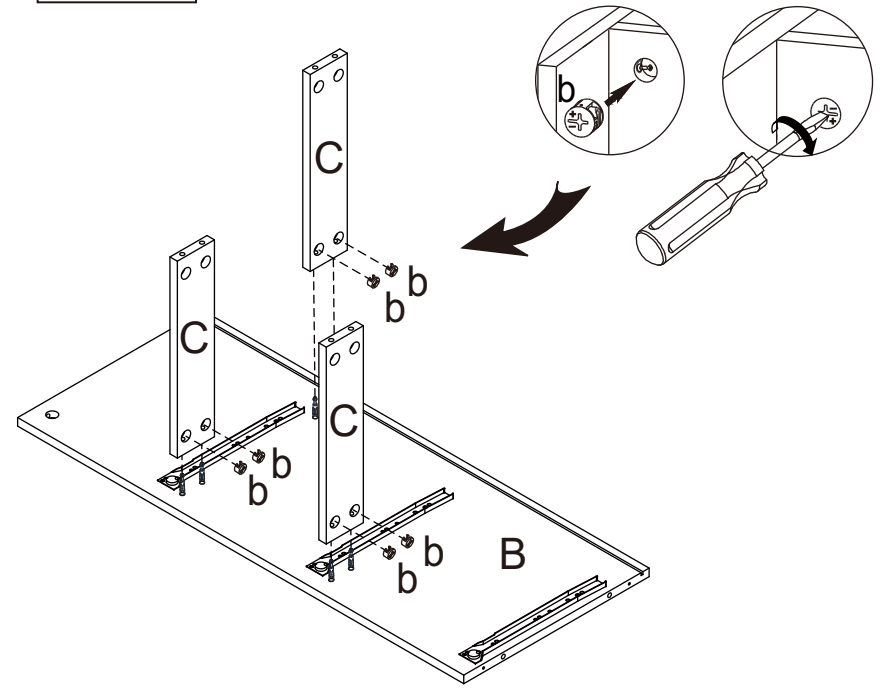

STEP 3

-  X6
-  X4
-  X6
-  X3

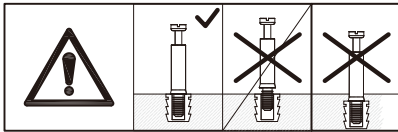
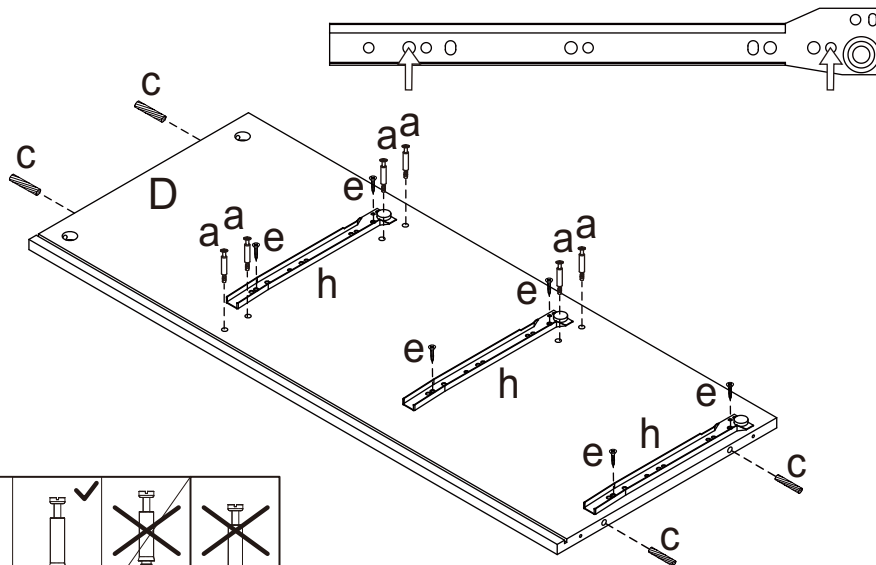

STEP 4

-  X6

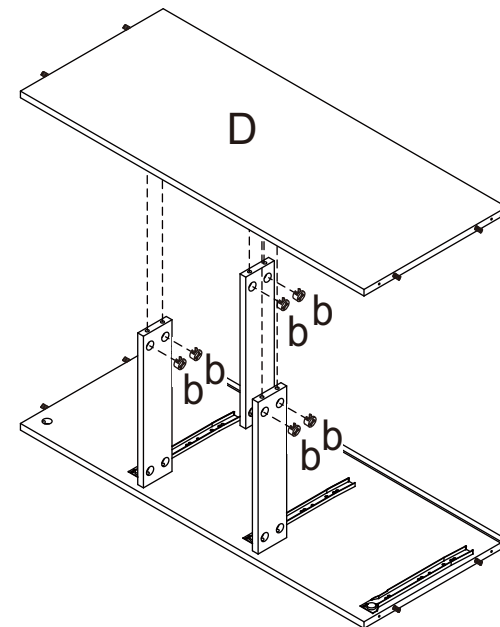

STEP 5

 X4

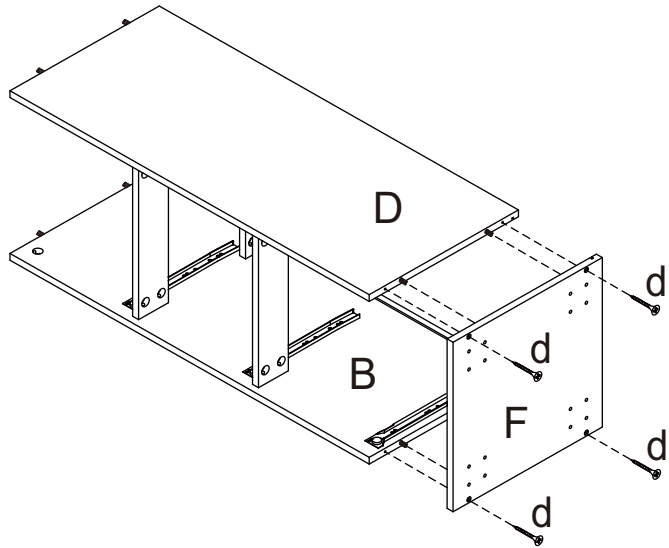

STEP 6

 X16  X2  X2

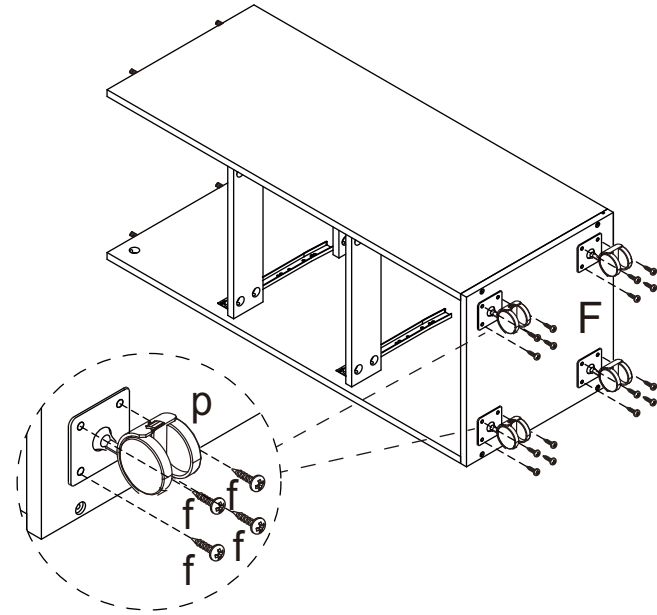

STEP 7

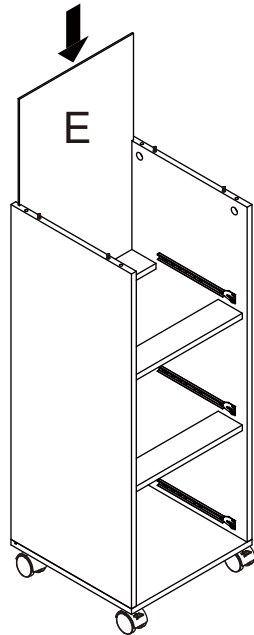

STEP 8

 X4

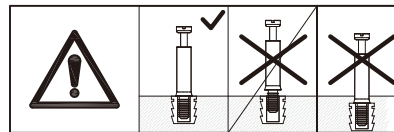
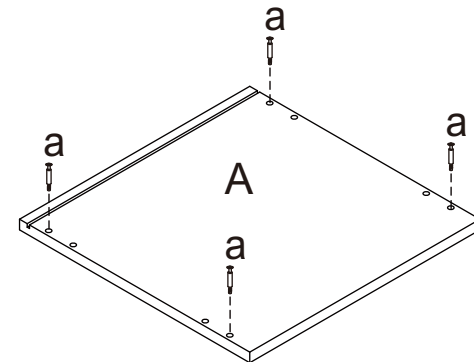

STEP 9

 X4

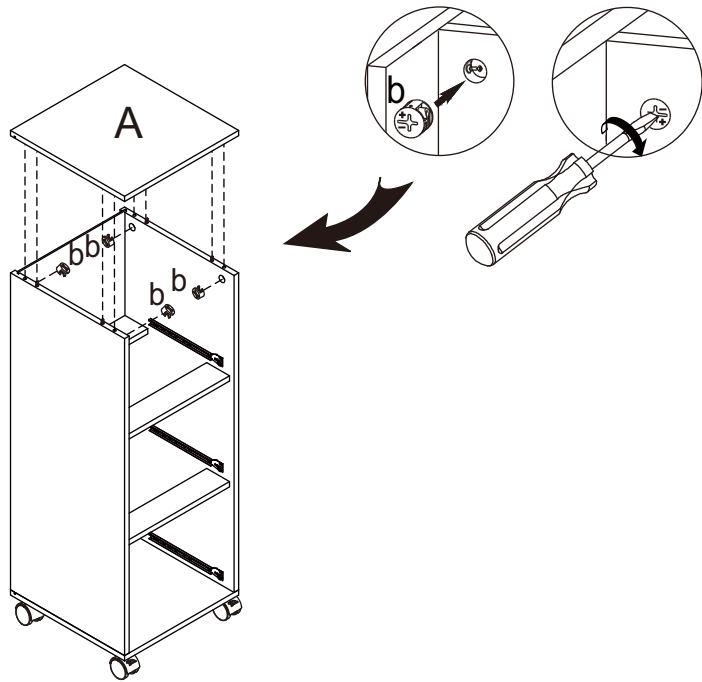

STEP 10

 X6  X6

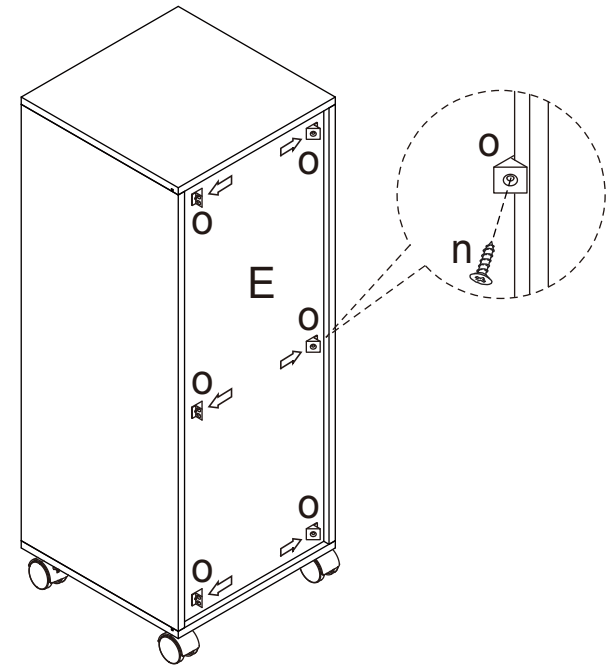

STEP 11

 X12

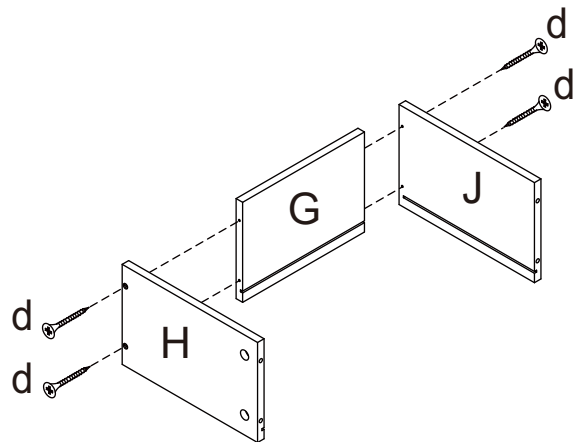

x3

STEP 12

 X12  X3  X3

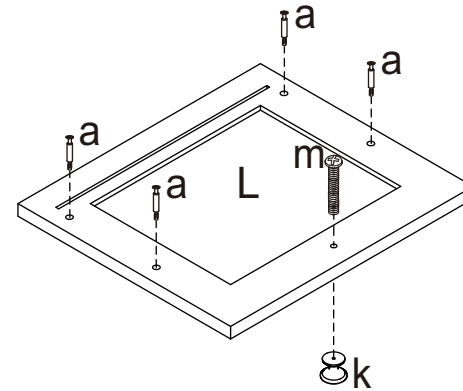

x3

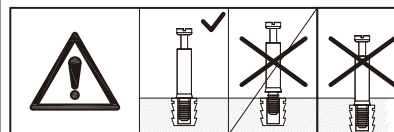



STEP 13

 X12

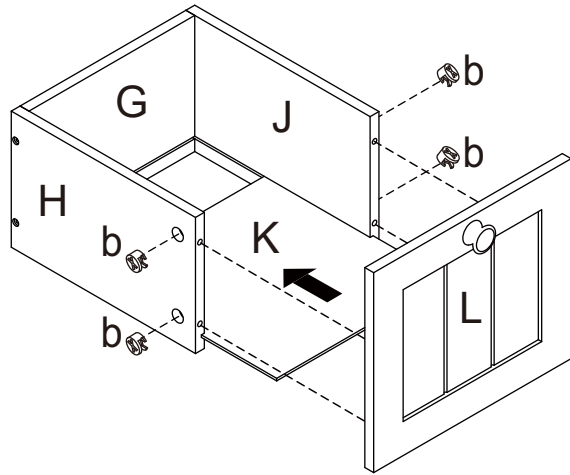
x3



STEP 14

 X12  X3  X3

x3

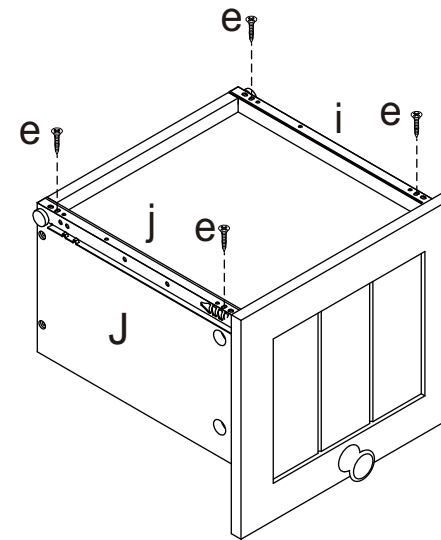
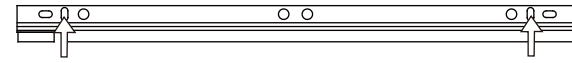

STEP 15

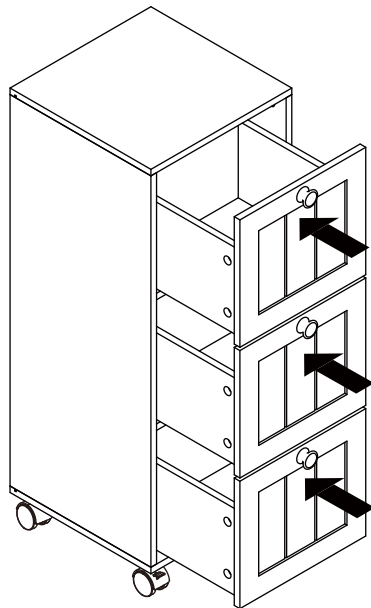

STEP 16

